



Programming and Operations Manual

HydraSupply XL™

HPU for operating hydraulic wedge barriers
with Smart Touch Controller



HydraSupply XL Single



HydraSupply XL Twin: One HydraSupply with
two controllers

HydraSupply XL™

TWIN HYDRASUPPLY XL

VALVES

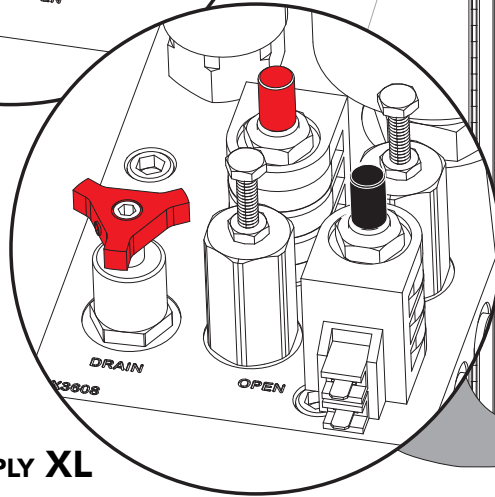
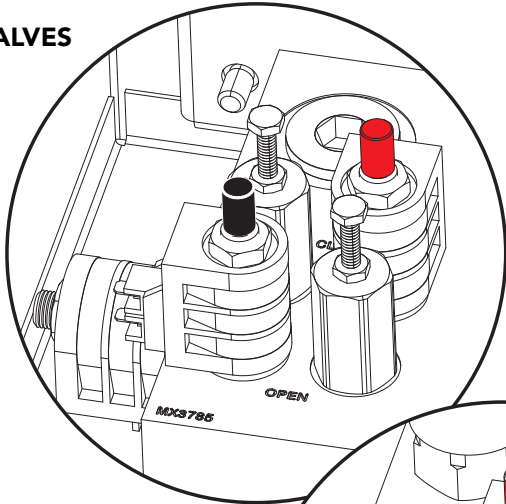

SINGLE HYDRASUPPLY XL VALVES

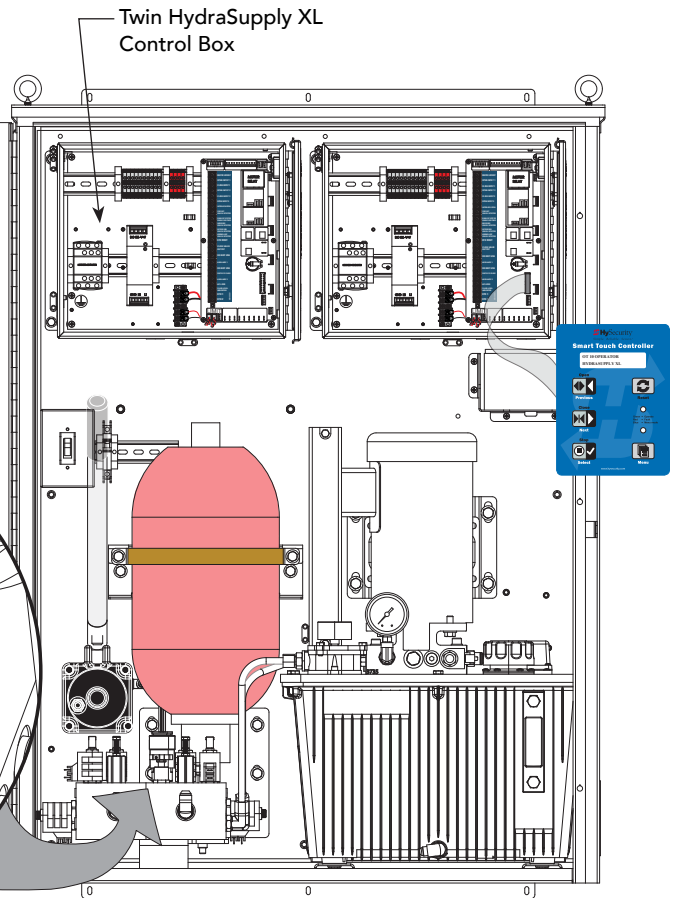

Programming & Operations Manual with HySecurity Smart Touch Controller

MX3970-01 Revision B

This document provides *Important Safety Information*, specifications, and references along with an overview of programming user and installer menu options, designing vehicle loop layouts, troubleshooting, and maintaining the gate operator.

 **HySecurity**[®]
a company of TheNiceGroup

www.SecureOpeners.com | (800) 878-7829 | Sales@SecureOpeners.com

HYDRAWEDGE SM50 COMPONENTS



During inclement weather, leave wedge blocking plate in the lowered position to avoid snow and ice build up inside the base. Be aware of freezing temperatures and its affect on the safety skirt and other equipment. In low temperature zones, consider a heater or heating coils as part of the site specification and installation.

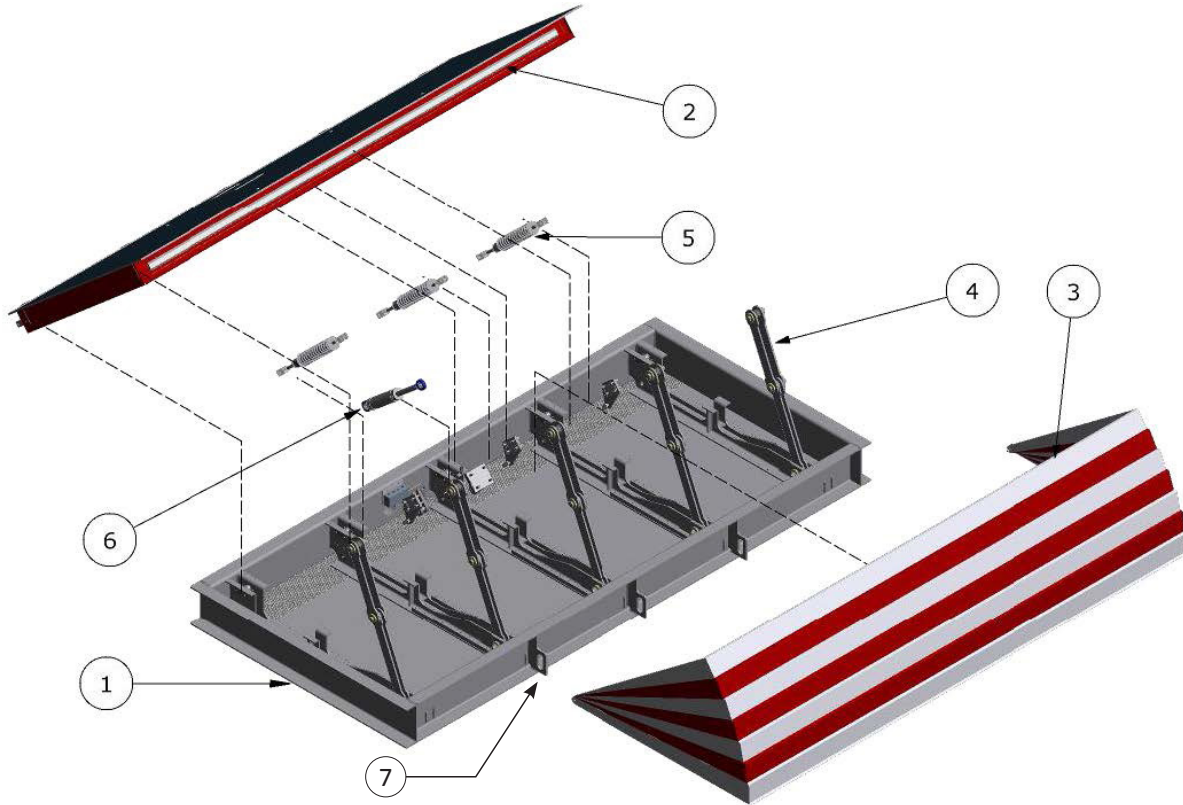
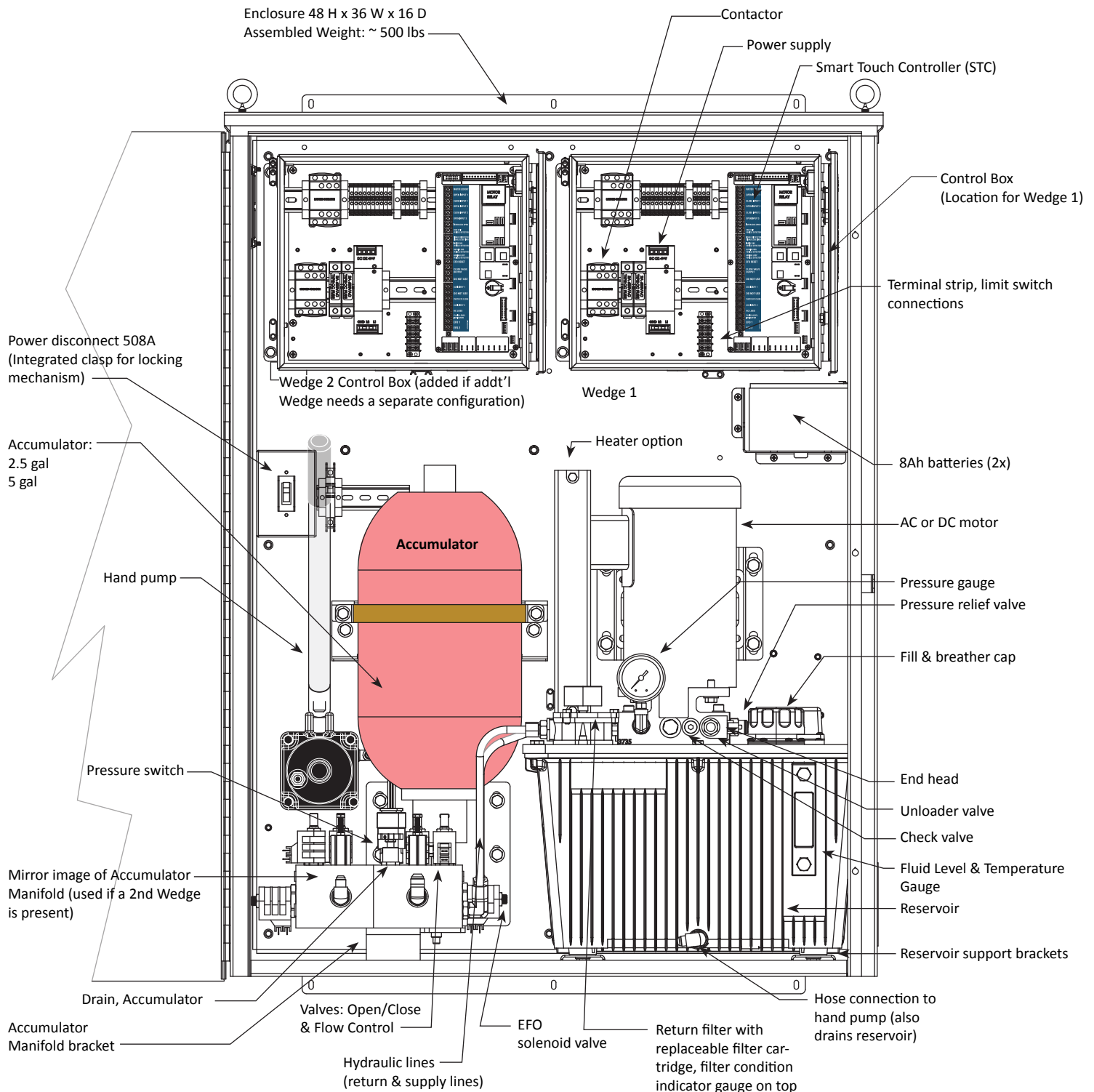

Table 1: HydraWedge SM50 Components

Bubble #	Component	Description
1	Base frame	The base frame is a welded assembly which is cast into the foundation. The base frame consists of the bearing points for the blocking plate and scissor joints. The whole assembly transfers the impact load into the foundation and soil. A perforated sheet, used for drainage, spans the full blocking width at the front and rear along the bottom of the base frame.
2	Blocking Plate	The blocking plate is a welded assembly. Five swiveling bearing points fasten it to the base frame. The blocking plate is raised and lowered by the hydraulic cylinder and the compression spring assembly. The blocking plate absorbs the energy during impact and deflects it into the foundation via the base frame and scissor joints.
3	Safety Skirt (optional)	The safety skirt is a protective cover. It consists of seven bent sheet metal plates, which are movably linked to each other. The safety skirt collapses during lowering of the blocking plate and rests in a protected area inside the base frame.
4	Scissor Joint	The scissor joint transfers the impact load through the blocking plate to the base frame. Pivot bolts fasten the five scissor joints to the blocking plate and base frame.
5	Compression Spring Assembly	The compression spring assembly assists the hydraulic cylinder in raising the blocking plate. As the blocking plate lowers, the spring assembly is automatically tensioned and compressed. The stored energy is released during the next raising session.
6	Hydraulic Cylinder	When extended, the hydraulic cylinder keeps the blocking plate in the raised position. The fluid, for the hydraulic cylinder, flows through hoses attached to a pump pack located in the HydraSupply XL cabinet. When triggered to run, the hydraulic cylinder operates as a hydraulic actuator and raises the blocking plate.
7	Lifting points	The base frame is fitted with four lifting points for safe transport. All four lifting points must be used when moving the base frame.

HYDRASUPPLYXL CABINET AND TERMINOLOGY



HydraSupply XL Cabinet

The cabinet houses the hydraulic pump pack, motor, Smart Touch Controller, heater, batteries and accumulator. See the illustration above for all components located in the HydraSupply XL cabinet. The cabinet is ventilated (heater optional) and can be installed at a maximum of 80 feet (25 m) from the HydraWedge SM50. The connection between the hydraulic cylinder in the wedge blocking plate is made via high pressure hydraulic hoses which are run through 4 inch conduit. The HydraSupply XL can be wall or post mounted on a separate foundation which must be erected on site. Refer to the installation instructions for site planning and design constructs.

INSTALLER CHECKLIST: HYDRAWEDGE SM50

The following list provides a high level overview of the tasks involved in installing the HydraWedge SM50 barrier gate operator. Take a moment to review the list and check off the items as you complete the install.

- Site Prep - concrete pad location/dimensions, conduit, rebar mat, Earth ground, and loop layouts.
- Install the supplied DANGER signs on wedge barrier. Signs must be viewable by vehicular traffic and maintenance personnel.
- Check for compliance with local codes, site conditions, UL 508A and NEC standards.
- Read *Installation Instructions*.
- When foundation bed is sufficiently compacted and drainage channels attached, move base frame and set rebar.
- Make sure conduit is in place for hydraulic hoses and high/low voltage, dual gates, earth ground, UPS, etc.
- Pour concrete slab. Allow appropriate time, moisture content, and temperature for curing. Curing plays an important role on strength development and durability of concrete. Concrete must maintain a minimum 4600 psi compressive strength.
- Run hydraulic hoses through conduit.
- Run high and low voltage wiring through conduit.
- Make sure AC and DC power disconnect switches are in the OFF position.
- Connect AC power.
- Connect batteries.
- Turn AC power and DC power disconnect switch ON.
- Set wedge blocking plate's limit switches.
- Access the User Menu or Installer Menu to customize your gate operator. See "*Initial Setup*" on page 15.
- Connect all accessory devices and loops to the Smart Touch Controller.
- Configure changes through the Installer Menu depending on the accessory devices that you have installed.
- Give a copy of the *Important Safety Information* and pertinent operator instructions to the end user. Show the end user how to:
 - ◆ Turn the power OFF and ON.
 - ◆ Adjust physical limit stops for wedge blocking plate open and close positioning.
 - ◆ Install the service strut before servicing or performing any maintenance on a raised blocking wedge.
 - ◆ Manually operate the wedge blocking plate.
- Take photographs of the completed installation site and save it in your business files.

Contents

HydraWedge SM50 Components.....	ii
HydraSupplyXL Cabinet and Terminology.....	iii
Installer Checklist: HydraWedge SM50	iv
WELCOME TO HySECURITY.....	1
Contact Information.....	1
Notices and Bulletins	2
Supplemental Documents.....	2
Hazardous Materials and Proper Disposal	2
IMPORTANT SAFETY INFORMATION.....	3
Safety - Installer Responsibilities	4
Safety - Owner/User Responsibilities.....	5
Limitation of Liability.....	6
Operation During Power Failure	6
Lowering the Blocking Plate	6
Raising the Blocking Plate (Hand Pump Operation)	7
Common Industrial Symbols.....	8
POWER.....	9
Installing the Earth Ground.....	9
AC Power Wiring: Site Considerations.....	10
AC Power Wiring: Wire Size Charts.....	11
Wiring Diagram: HydraWedge SM50	12
Wiring AC Power.....	13
Turning the Power Disconnect Switches ON	14
DC Power Supply (UPS) Connections.....	14
INITIAL SETUP.....	15
Grounding, Breather Cap Installation & Handling	16
Installing a Push Button Emergency Fast Operate (EFO) Switch	17
Emergency Fast Close Speeds	17
EFO Connections: Wiring Diagram.....	17
Installing an Emergency Fast Operate (EFO) Reset Switch Push Button Device	18
BI-PARTING & DUAL GATE SYSTEMS	21
Connecting an Interlocked Pair (Dual Gate).....	21
Dual Gate Wiring Connections.....	22
Dual or Sequenced Gates: Power, Software & Accessory Requirements	23
Programming a Dual Gate (Interlocked Pair)	23
Connecting Sequenced Gates	24
Sequenced Gate 1: StrongArm M30 & HydraWedge SM50.....	26
Sequenced Gate 2: StrongArm M30 & HydraWedge SM50.....	27
Sequenced Gate 3: SlideDriver & HydraWedge SM50.....	28
Sequenced Gate 4: SlideDriver & HydraWedge SM50.....	29

DISPLAY & MENU OPTIONS.....	31
Initial Setup	31
Understanding the Display and Keypad	31
Menu Mode and the STC Keypad	32
Menu Mode Navigation	32
Run Mode and the STC Keypad	33
Viewing Operator Gate Scrolling Status	33
Stop the Status Display Scrolling	34
Change the Contrast on 7 Segment Displays.....	34
Check the Software Version	34
Check Time and Date	34
User Menu	35
Table 9: User Menu	36
Installer Menu	37
Table 10: Installer Menu	38
Setting the Close Timer	41
Test the Operator.....	42
STC INPUTS & WIRING.....	43
Overview of the Smart Touch Controller.....	44
Integrating with Security Systems	45
Smart Touch Controller Inputs.....	46
STC Terminal Inputs	46
User Relays - Programming Procedure.....	48
Extended Relay Module Option	51
TROUBLESHOOTING	53
System Diagnostic Messages.....	53
Table 13: Troubleshooting Codes.....	54
Access the Event Log through the User Menu	58
GENERAL MAINTENANCE	59
Smart Touch Analyze and Retrieve Tool (S.T.A.R.T.)	59
What You Need.....	59
Installing S.T.A.R.T. Software.....	59
Software Maintenance.....	60
Electrical Controls	60
Clock Battery Replacement	60
Mechanical Maintenance	61
Hydraulic System Maintenance	61
Adjusting the Pressure Relief Valve	62
HydraWedge SM50 Maintenance Schedule	63
HydraSupply XL Maintenance Schedule	64
HydraWedge SM50 & HydraSupply XL Specifications.....	66

Tables

- Table 1: HydraWedge SM50 Components..... ii
- Table 2: HydraSupply XL Wire Size Chart – 2 Horsepower, 60 Hz 11
- Table 3: HydraSupply XL Wire Size Chart – 5 Horsepower, 60 Hz 11
- Table 4: Smart Touch Controller Menu Mode Navigation Buttons 15
- Table 5: Accumulator Precharge Pressure Values 19
- Table 6: Dual Gate Installer Menu Settings 23
- Table 7: Smart Touch Controller Menu Mode Navigation Buttons 32
- Table 8: Scrolling Status Displays 34
- Table 9: USER Menu HydraSupply XL 36
- Table 10: INSTALLER Menu HydraSupply XL 38
- Table 11: Smart Touch Controller Inputs 48
- Table 12: Programmable User Relays 50
- Table 13: Troubleshooting Codes, Causes and Corrective Action 56
- Table 14: Pressure Relief Valve Settings..... 64
- Table 15: HydraWedge SM50 Maintenance Schedule 65
- Table 16: HydraSupply Maintenance Schedule 66

Welcome to HySecurity

Thank you for purchasing premium HySecurity products. At HySecurity Gate, Inc., we pride ourselves on quality.

All gate operator designs are tested for hundreds of thousands of cycles before being released to the market. Fortified crash barrier, traffic barrier, slide, swing, and vertical lift gate operators have all received rigorous testing and certification. Security, low maintenance, flexible configuration, and overall toughness are the foremost criteria for all HySecurity products.

Our commitment to quality and innovation will become evident as the features and performance of the expertly engineered and manufactured HydraWedge SM50 become familiar to you. Thank you again for the confidence you've shown in becoming part of the HySecurity family and in choosing a premium industry-leading product.



HySecurity Gate, Inc. Headquarters in Kent, WA

CONTACT INFORMATION

Qualified HySecurity distributors are experienced and trained to assist in resolving any problems.

Before contacting your distributor or HySecurity Technical Support, obtain the serial number of your operator.

For information about HySecurity training for installers, maintenance personnel, and end users, refer to the company website at .

NOTICES AND BULLETINS

Installers should visit HySecurity's online Technical Support page at www.hysecurity.com or contact HySecurity prior to installing product to make sure they have received the most up-to-date information.

SUPPLEMENTAL DOCUMENTS

The product literature is comprehensive and contains information needed to plan, install, operate and maintain your gate operator. Additional general information concerning HySecurity gate operators can be obtained from the following:

- HySecurity website public domain contains published materials for UL 325 - 2016 Monitored External Entrapment Protection sensors, www.hysecurity.com/gatesafety
- HySecurity website www.hysecurity.com - Contains links to the product catalog, product order form, operator manuals, operator software downloads, technical support bulletins and other useful information.
- S.T.A.R.T. - Smart Touch Analyze and Retrieve Tool - User's Guide (D0049) detailing the extensive software, diagnostic and troubleshooting capabilities of the Smart Touch Controller board.
- DC Power Supply with HyCharger DC, supplement
- Technical Bulletins (as applicable).

NOTE: Technical Bulletins are automatically issued to registered users of HySecurity products.

HAZARDOUS MATERIALS AND PROPER DISPOSAL

Be aware of the international, federal, and local codes in your area and how best to handle hazardous waste materials.

The pump pack fluid, found in all hydraulic HySecurity operators, can be recycled. Gear oil, found in HySecurity electromechanical gate operators, can also be recycled. If the fluids are mixed or contaminated with any solvents or other chemicals, they become hazardous waste. Hazardous waste requirements for storage and disposal must be followed.



If the gate operator has a battery backup system, the batteries contain materials that are considered hazardous to the environment. Proper disposal of the battery is required by federal law. In the U.S.A., refer to federal EPA guidelines for proper hazardous waste disposal.

IMPORTANT SAFETY INFORMATION

Hazards, associated with hardened vehicle barriers, can be reduced with proper site design, installation, and use. Installers, maintenance crews, and owners/users must read and follow the safety requirements found in the HySecurity product documentation.

It is important that only qualified installers handle the installation of HySecurity equipment and gate operator. A “qualified” installer has one of the following:

- A minimum of three years experience installing similar equipment
- Proof of attending a HySecurity Technical Training seminar within the past three years
- Significant manufacturer endorsements of technical aptitude in gate operator installation and operation

HySecurity vehicular barriers are marked to UL 508A for electrical safety. More importantly for high security installations, HySecurity barriers are either engineered to meet and/or tested to ASTM F2656.



A vehicular barrier, by its very nature, can potentially damage vehicles or equipment and injure people. Vehicle barriers prevent unauthorized vehicular traffic from passing through a particular site. If inadvertent contact with a hardened vehicular barrier transpires, the possibility of damage to property, and injury, or even death, to persons may occur. It is therefore incumbent on the site designer, installer, and property owner to ensure that these hazards are mitigated and the public is warned of the existence of a potential hazard. Read all the product safety information prior to installation. Verify the gate operator is installed to comply with all safety standards and local and federal regulations.

1. **READ AND FOLLOW ALL INSTRUCTIONS.** Read the gate operator’s product manual and review all the product labels and literature prior to installing, operating, or maintaining the automatic gate operator.
2. Install the barrier only in accordance with the instructional materials supplied with it.
3. Never use vehicular barriers for pedestrian traffic. Allow for pedestrian traffic separate from vehicular traffic. **NO ONE SHOULD CROSS THE PATH OF A MOVING BARRIER.**
4. Never let children operate or play with barrier controls. Keep all remote controls, especially radio transmitters, away from children. Do not allow children to play on or around the barrier.
5. Employ traffic calming features to limit speed, such as 90 degree turns just prior to the access point, chicanes set up with bollards or jersey barriers, or other means of slowing vehicular traffic.
6. Provide clear indication that there is an active vehicular barrier in use and that there are consequences of inadvertently or purposely running into it.
7. Keep the barrier properly maintained per the maintenance instructions provided with the equipment.
8. For detecting vehicles in the active zone and preventing closing on a vehicle in transit, it is highly recommended to install vehicle detectors in accordance with the product documentation. **KEEP VEHICULAR BARRIERS AND GATES PROPERLY MAINTAINED.** Read the product manuals. Have a qualified service person make repairs to hardware and replace batteries in accessory or external entrapment protection sensors on a regular basis.
9. In the case where Emergency Fast Operation (EFO) is enabled, it is highly recommended that a covered switch be used, or some other means of mitigating the risk of accidental actuation (dual action switch, dual palm switches, etc.).
10. Ensure the vehicular barrier is properly grounded and the incoming power matches the voltage label.

SAVE THESE INSTRUCTIONS

SAFETY - INSTALLER RESPONSIBILITIES

NOTE: In the following safety information, the term “gate” refers to the hardware that the automatic gate operator is moving: gate, barrier arm, bollard or wedge.

- Study all of the accompanying product literature prior to installing, operating, or maintaining the HydraWedge SM50. Take the time required to allow for site provisions, proper installation and alignment of the blocking plate, and verification of a fully functional operator. A proper installation will improve user safety, reduce maintenance, guarantee longest system life, and ensure customer satisfaction.
- Install the HydraWedge SM50 according to the instructions found in the installation literature. The foundations must be installed in soils (natural or controlled fill material) that are suitable for construction and foundation sub grade and approved by the site engineer prior to construction.
- Verify the gate operator usage class for the site. For all gate operators other than Crash-rated, refer to Identifying Gate Operator Category and Usage Class in the product manual. Install the operator only when the gate operator class is correct for the site, size, and type of gate.
- Install the supplied DANGER signs so they are clearly visible.
- Make sure all exposed pinch points are guarded.
- Reduce the risk of entrapment throughout the entire travel path by making sure the gate is installed in a location which ensures the required clearance between the gate and adjacent structures when opening or closing.
- Install external entrapment protection sensors so pedestrians are protected from entrapment in both directions of gate travel and all hazard areas are fully protected. Note that no IES exists in Crash products.
- Never disable the Warn Before Operate buzzer. This buzzer provides an alert that the gate is about to move.
- Mount access control devices beyond reach of the gate operator. The control devices that operate the gate must:
 - ♦ Be located in a clear line of sight to the gate. Locate controls (Open, Close, Stop/Reset) where a user will have a clear view of the gate.
 - ♦ Be mounted beyond 6 feet (183 cm) of the gate, to prevent users from touching or accessing the gate while operating the controls. People attempting to access the controls by reaching through or around the gate can be seriously injured or killed by the moving gate.
 - ♦ Incorporate a security feature to prevent unauthorized use.
- Open and close the gate to confirm that it was properly installed and to ensure reduced risk of entrapment. Verify the clearance between the gate and adjacent structures to avoid entrapment. Have a qualified technician test the gate monthly.

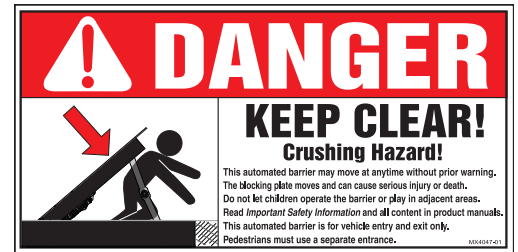

NOTE: When you complete the installation, demonstrate the safety features and operation of the gate operator to the end user:

- ♦ Clearly explain and demonstrate the consequences of removing or defeating any of the safety features.
- ♦ Show how to turn the power on and off.
- ♦ Show how to use the manual override.
- ♦ Use the Emergency Stop Button. (If an emergency stop button is not available, show the user where the Stop button is located.)
- ♦ Take photographs of the completed installation site and save it in your business files.

NOTE: Gate operator instructions must be given to the owner.

SAVE THESE INSTRUCTIONS

SAFETY - OWNER/USER RESPONSIBILITIES

As the owner/user, you are responsible for the correct and safe installation, operation and maintenance of the HydraWedge SM50 barrier gate operator. It is of the utmost importance that you read and follow the specific instructions and precautions found in the *Important Safety Information* addressed in this manual. In addition, you must adhere to the safety standards of applicable federal, state, and local safety regulations, industry standards, and/or procedures.

NOTICE

For installations outside the United States, make sure that you follow the applicable international, regional, and local safety standards.

- READ AND FOLLOW IMPORTANT SAFETY INFORMATION.
- Learn how to turn the power on and off. Learn how to manually operate the barrier.
- DANGER and WARNING signs supplied with the barrier gate operator must remain installed and clearly visible on both secure and public sides of the barrier gate.
- Do not physically disable the warning buzzer and NEVER disconnect or cut its wires. The buzzer provides compliance with the Manual on Uniform Traffic Control Devices (MUTCD) standards. Disabling the warning buzzer may increase the risk of death or serious injury.
- Safeguard against any possible entrapment. Always use a structural mechanical support when servicing or performing maintenance around the equipment.
- Do not remove entrapment devices or any other safety features.
- Have a professional and qualified person routinely inspect the equipment's hardware and test overall barrier gate operation and the performance of entrapment protection sensors.
- Have a qualified service person make repairs to gate hardware and equipment to keep the equipment running smoothly.
- The equipment is used in the commercial and industrial sectors. The owner is therefore subject to legal obligations pertaining to work safety and must conduct risk assessment, accident-prevention, and environmental-protection per applicable regulations and on-site conditions.
 - ◆ The owner must verify over the entire life cycle of the equipment whether the instructions shipped with the product are in compliance with the current status of regulations and, if not, be responsible for the necessary adjustments.
 - ◆ The owner must ensure that staff and personnel who handle or maintain the equipment have read and understand the associated product literature and instructional information.
 - ◆ The owner must ensure that required personal protective equipment is used on site.
 - ◆ The owner is responsible for the working condition of the equipment once initial commissioning has taken place..

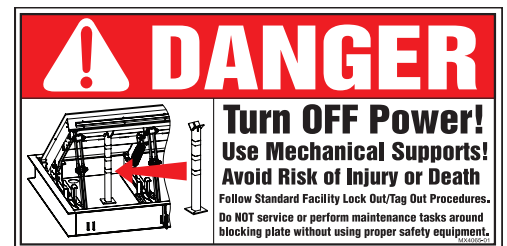

SAVE THESE INSTRUCTIONS

LIMITATION OF LIABILITY

The manufacturer assumes no liability for damage in the following cases:

- Non-observance of the information available in the product manuals.
- Use of equipment deviating from its intended use
- Assignment of untrained personnel
- Unauthorized retrofitting
- Technical changes
- Use of non-approved spare parts

For special models, additional ordering options or in cases where the most recent technical changes have been implemented, the actual scope of deliver may deviate from the explanations and representations described here. Illustrations in this manual are intended to facilitate basic understanding and may differ from the actual configuration.

OPERATION DURING POWER FAILURE



Stay clear of the blocking plate and base frame when using the manual override. Severe injury and death can occur if public or personnel are caught inside the base frame or come in contact with the blocking plate. Check the area around the HydraWedge SM50 and verify personnel and public are a safe distance from the base frame and blocking wedge before attempting a manual override.

Lowering the Blocking Plate

Given the weight of the blocking plate, gravity causes the blocking plate to lower to grade level when the OPEN solenoid valve is activated. To manually lower the blocking plate:

1. Pull up on the **black** OPEN solenoid valve knob located on the accumulator manifold and hold it in an elevated (activated) position.
2. When the blocking plate is lowered and on grade, close the valve by releasing it (reseats it). If valve does not reseat, rotate knob slightly.

Raising the Blocking Plate (Hand Pump Operation)

NOTE: Make sure the OPEN solenoid valve on the accumulator manifold is closed. See step 2 above.

1. Check the pressure in the accumulator. If pressure exists, it'll be easier to raise the blocking plate with the hand pump.
2. Pull up on the **red** CLOSE solenoid valve knob. Twist and release it. The valve stem must remain elevated (activated).
3. Place the handle in the hand pump bracket. Insert the locking pin to secure it.
4. Begin pumping and continue until the blocking plate is raised to the level you desire.
5. When the blocking plate is raised. Close the solenoid valve by turning the **red** knob until it retracts. Be sure the valve stem drops and re-seats closed.

NOTE: If the blocking plate is raised for an extended period of time without AC or DC power, use a service strut to support the wedge blocking plate and hold it in the raised position.

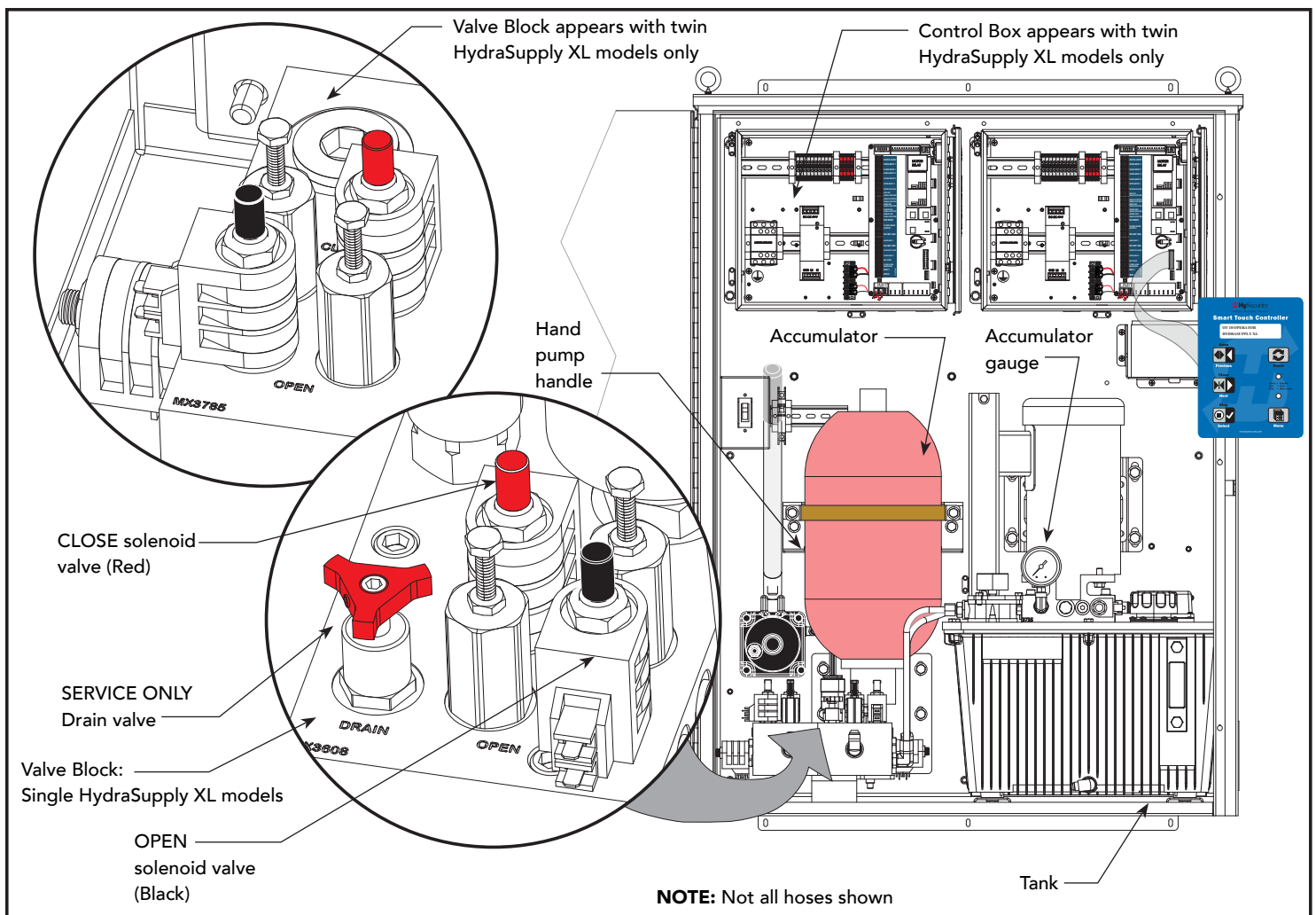

Remember to close the solenoid valves. If either the OPEN and CLOSE solenoid valves or the drain valve remains open, the hydraulic fluid will flow back to tank, draining the accumulator completely. The accumulator pressure gauge will show 0 psi. Without accumulator pressure, the EFO will not operate.

SAFETY NOTICES

The following four levels of safety notices are used where applicable within this manual; each notice contains information specific to the situation.



Indicates death or serious injury will occur if the hazardous situation is not avoided.



Indicates death or serious injury could occur if the hazardous situation is not avoided.



Indicates mild or moderate injury could occur if the hazardous situation is not avoided.

NOTICE: Indicates damage to equipment is probable if the hazardous situation is not avoided.

COMMON INDUSTRIAL SYMBOLS

The following international safety symbols may appear on the product or in its literature. The symbols are used to alert you to potential personal injury hazards. Obey all safety messages that follow these symbols to avoid possible injury or death.

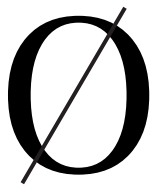

**Electrical Phase
Symbol**



**Ground
Symbol**



**- Danger -
Keep Away**



**Entrapment
Zone**



**Possible
Pinch Point**



**Attention
- Take Note -**

How to wire the operator is presented in the *Installation Instructions*, but detailed information about the earth and equipment ground, wiring to AC power, and DC power considerations are described in this section.

INSTALLING THE EARTH GROUND

An earth ground refers to the grounding rod and accompanying equipment ground which need to be installed to safeguard against potential electrical shock and damage to personnel and equipment.



The potential for lightning discharge exists with all gates, fences and gate operators. National Electric Code (NEC) - Article 250 requires a separate earth ground in addition to the required equipment ground.

HySecurity recommends grounding the operator with a separate earth ground rod (or a similar device) to shield the operator against electromagnetism and other electrical signals that may cause, erratic operation with, or damage to, the Smart Touch Controller and other electrical parts.

For earth grounding requirements in the U.S.A., refer to the National Fire Protection Association (NFPA) 780 - Standard for the Installation of Lightning Protection Systems. Highlights of the standard include:

- The ground rod must be UL listed copper-clad steel, solid copper, hot-dipped galvanized steel, or stainless steel. Minimum requirements: ½ inch (13 mm) diameter and 8 feet (244 cm) in length.
- The ground rod is driven into the earth (refer to local codes for proper depth requirements).
- The ground rod is electrically bonded to the chassis with a single length of un-spliced 6 AWG copper wire less than 3 feet (91 cm) long. Due to the large concrete foundation on crash products, make the necessary adjustments to accommodate for earth ground requirements.
- Local jurisdictions may impose other requirements above the NEC, Article 250 and NFPA 780. Consult the local codes and regulations regarding requirements in your area.

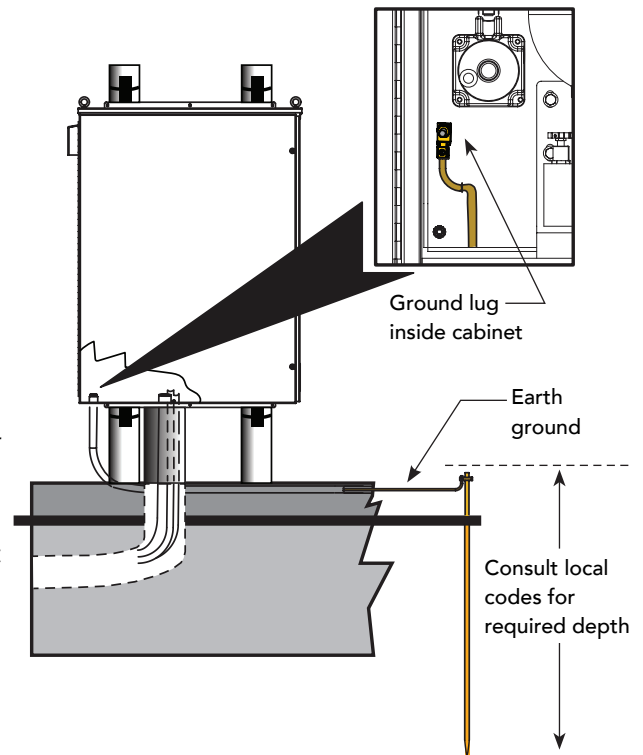

NOTICE: Properly grounding the gate operator is critical to gate operator performance and the life of its electrical components. Use sufficient wire size during installation. If you do not ground the operator with a separate earth ground, you risk voiding the HySecurity Warranty.

AC POWER WIRING: SITE CONSIDERATIONS



Both HydraSupply XL and the wedge base/blocking plate must be plumb and level, and on grade with the roadway surface. Slope drainage away from equipment and wedge base area.

Verify AC power supply wires and low voltage (accessory power) wires run through two separate conduits. The higher voltage from the AC power supply may cause interference and anomalies in HydraWedge SM50 operation if the high and low voltage wires are routed through the same conduit.

HySecurity gate operators are intended for permanent installation. Make sure you prepare the site with the following main power considerations:

- Proper wiring is being used and all electrical wiring and hydraulic hoses are properly routed via conduits.
- Distance of the wire run from the main panel to the gate operator. Make sure the wire size of the branch circuit supplying power to the gate operator is large enough to avoid excess voltage drop. See “AC Power Wiring: Wire Size Charts”.
- The available power source matches the electrical requirements specified on the voltage nameplate.
- A 20A circuit (minimum) protected with a 20A Inverse Time Breaker is provided in the field.

NOTE: Single phase (1Ø), 208VAC, 5 hp requires a 30A circuit minimum. Installer will need to supply the 30A breaker.

- Verify that the operator is electrically grounded per NFPA 780 and NEC Article 250, and local codes.



Each gate operator is built to run on a specific line power voltage and phase. Failure to ensure the source voltage, phase and frequency match what is specified may result in severe damage to the equipment.

AC POWER WIRING: WIRE SIZE CHARTS

The maximum distance shown is from the operator to the power source, assuming that source power is from a panel box with adequate capacity to support the addition of this motor load. The values are for one operator, with no other loads applied to the branch circuit. Avoid placing more than one operator to a circuit, but if you must, be certain to reduce the maximum allowed wire distance by half.

NOTE: Distance shown in U.S. Standard "feet." Metric equivalent shown in parentheses.

Table 2: HydraSupply XL Wire Size Chart – 2 Horsepower, 60 Hz					
Phase Ø	Single	Single	Three Phase	Three Phase	Three Phase
VAC	208	230	208	230	460
Amps	14.2	13.6	6.5	6.2	3.1
Wire Gauge	Distance	Distance	Distance	Distance	Distance
12	110 (33m)	130 (40m)	245 (75m)	280 (85m)	1130 (344m)
10	175 (53m)	205 (62m)	390 (119m)	450 (137m)	1800 (549m)
8	280 (85m)	325 (99m)	615 (187m)	710 (216m)	2840 (866m)
6	445 (135m)	515 (157m)	975 (297m)	1130 (344m)	4550 (1387m)
4	710 (216m)	815 (248m)	1545 (471m)	1790 (546m)	7200 (2194m)
2	1130 (344m)	1305 (398m)	n/a	n/a	n/a

Table 3: HydraSupply XL Wire Size Chart – 5 Horsepower, 60 Hz				
Phase Ø	Single	Three Phase	Three Phase	Three Phase
VAC	208	208	230	460
Amps	27.0	16	15.4	7.7
Wire Gauge	Distance	Distance	Distance	Distance
12	65 (20m)	100 (30m)	115 (35m)	455 (139m)
10	105 (32m)	160 (49m)	180 (55m)	725 (221m)
8	165 (50m)	250 (76m)	285 (87m)	1150 (350m)
6	260 (79m)	400 (122m)	455 (139m)	1800 (549m)
4	410 (125m)	630 (192m)	720 (219m)	2900 (884m)
2	650 (198m)	1305 (398m)	n/a	n/a



Single phase (1Ø), 208VAC, 5 hp requires a 30A circuit minimum. Installer will need to supply the 30A breaker.

WIRING DIAGRAM: HYDRAWEDGE SM50

NOTE: For additional wiring diagrams, such as Emergency Fast Operate and DC Power, see Wiring Diagrams in the Reference section.

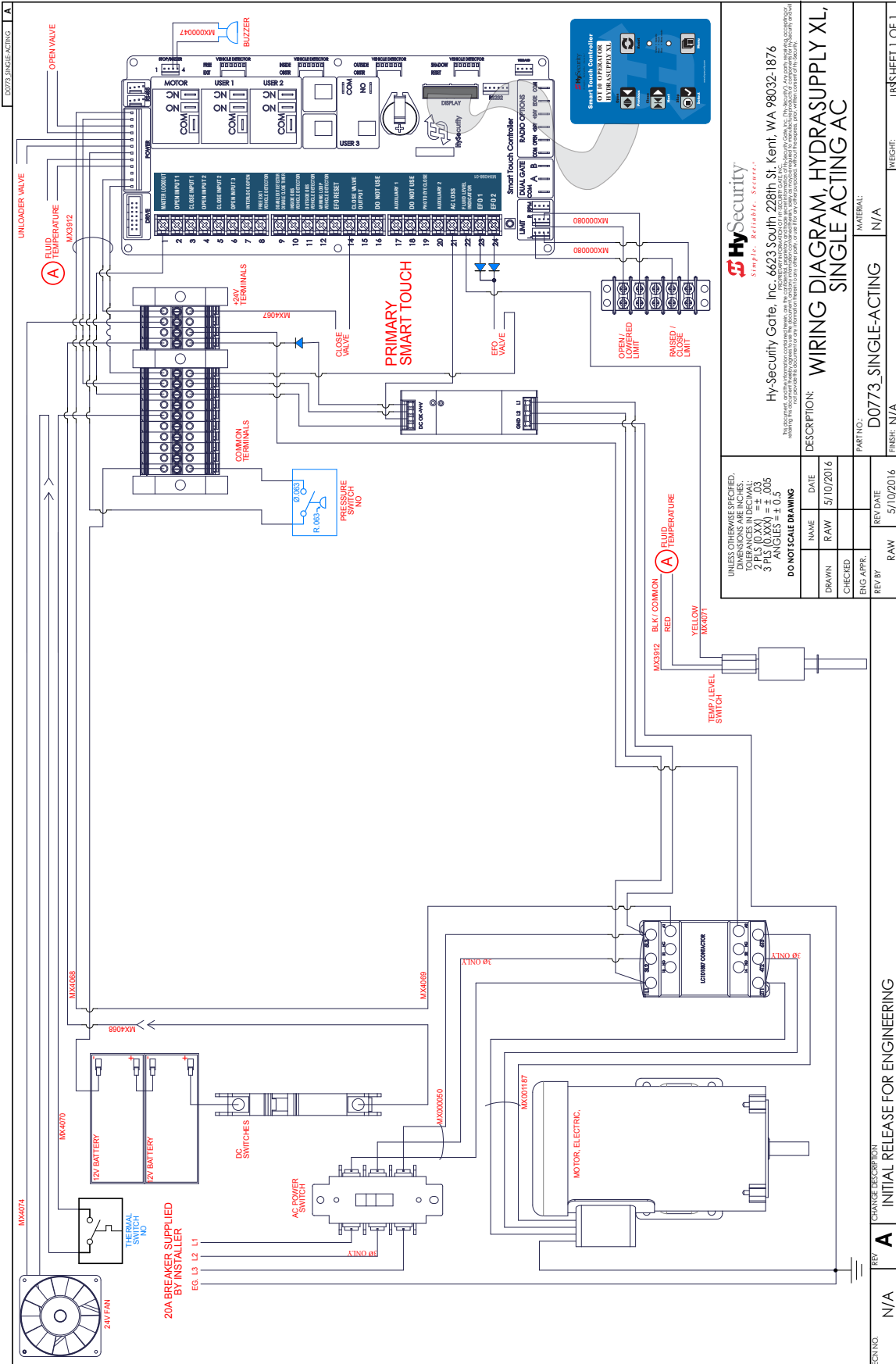

<p>UNLESS OTHERWISE SPECIFIED, DIMENSIONS ARE IN INCHES. TOLERANCES IN DECIMAL: 2 1/16 (0.125) = ± 0.03 3/16 (0.1875) = ± 0.06 ANGLES = ± 0.5</p> <p>DO NOT SCALE DRAWING</p>		<p>HySecurity Simple. Reliable. Secure.</p> <p>HySecurity Gate, Inc. 6623 South 228th St. Kent, WA 98032-1876</p> <p><small>This drawing is the property of HySecurity Gate, Inc. It is to be used for the specific project and location only. It is not to be reproduced, stored in a retrieval system, or transmitted in any form or by any means, electronic, mechanical, photocopying, recording, or by any information storage or retrieval system, without the prior written consent of HySecurity Gate, Inc.</small></p>	
<p>DESCRIPTION: WIRING DIAGRAM, HYDRASUPPLY XL, SINGLE ACTING AC</p>		<p>PART NO.: D0773_SINGLE-ACTING</p>	
<p>NAME: RAW</p>		<p>DATE: 5/10/2016</p>	
<p>DRAWN: RAW</p>		<p>REV. DATE: 5/10/2016</p>	
<p>CHECKED: [Blank]</p>		<p>ENG APPR: [Blank]</p>	
<p>REV BY: [Blank]</p>		<p>RAW</p>	
<p>REVISION: INITIAL RELEASE FOR ENGINEERING</p>		<p>MATERIAL: N/A</p>	
<p>REV: A</p>		<p>FIG. NO.: N/A</p>	
<p>CHG. DESCRIPTION: [Blank]</p>		<p>REQD.:</p>	
<p>DATE: N/A</p>		<p>LS\$SHEET 1 OF 1</p>	

WIRING AC POWER

The HydraWedge SM50 has separate *Installation Instructions* that explain how to connect to AC power. For reference purposes, the same information is provided below.

Size the primary wires. Consider the voltage and length of the wire run from the main power panel. See “AC Power Wiring: Site Considerations” on page 10.



Turn OFF AC power at the source (circuit breaker panel) before accessing the wires in the HydraWedge SM50. Follow facility Lock Out/Tag Out procedures. Make sure all power disconnect switches are in the OFF position. Follow all electrical code standards and regulations.



Wiring of gate operators must conform to NFPA and NEC standards and comply with all local codes. When the installation is compliant and complete, turn on AC power at the source and inside the HydraSupply XL.

1. **Connect to Power:** Unscrew the cover of the disconnect switch. Inside, 3 terminals and a ground are available for connection to a power source (1Ø or 3Ø). View illustration. If connecting to single phase (1Ø), omit wires (do NOT connect) to L2 and T2 terminals.
2. **Secure incoming AC power wires to their appropriate terminals.**
3. **Attach the green ground wire** to the ground lug in the switch plate.

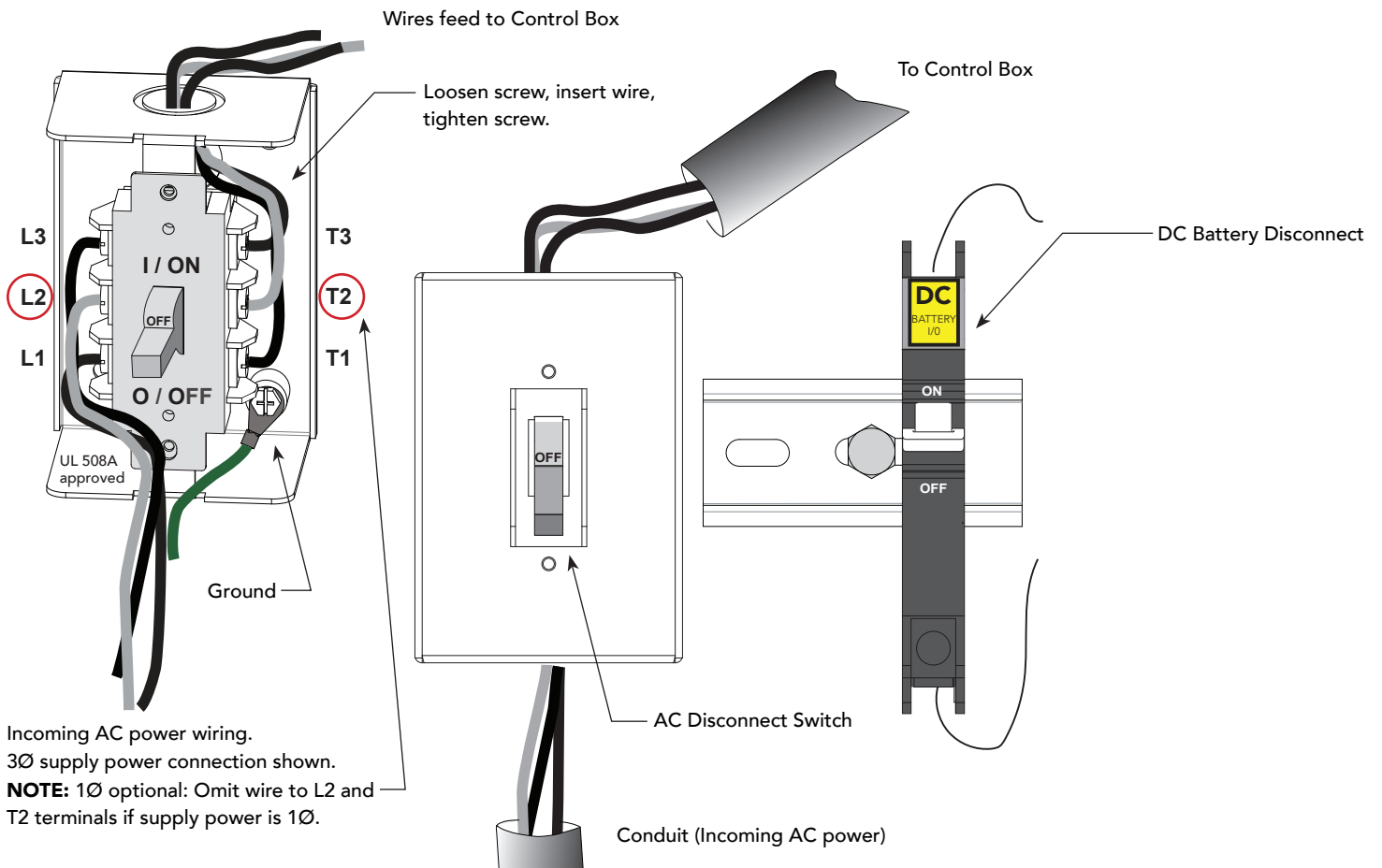

TURNING THE POWER DISCONNECT SWITCHES ON



Wiring of gate operators must conform to NFPA and NEC standards and comply with all local codes. When the installation is compliant and complete, turn on AC power at the source and at the control box. Before turning the power switch ON, be sure to replace the yellow vent plug with the breather cap. See page 16.

The AC power disconnect switch is located in the enclosure on the left side, below the fan.

When power is turned ON, a green status light on the Smart Touch Controller blinks. The status light appears below the coin battery and indicates that the processor is receiving power.

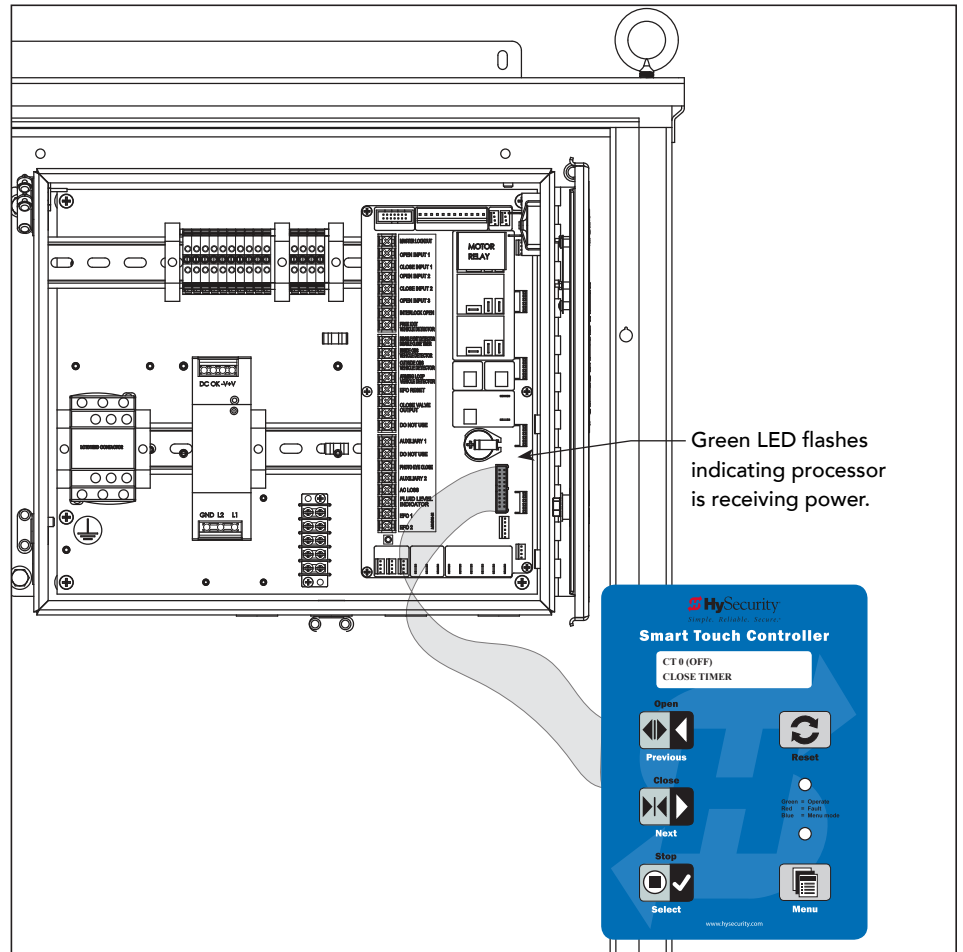
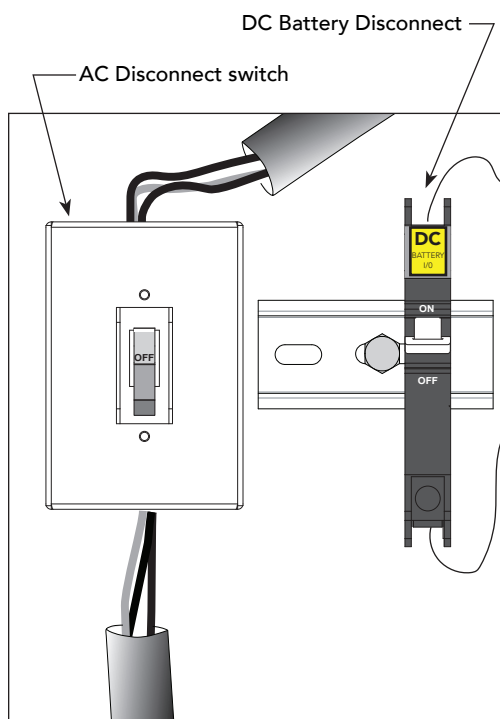

DC POWER SUPPLY (UPS) CONNECTIONS

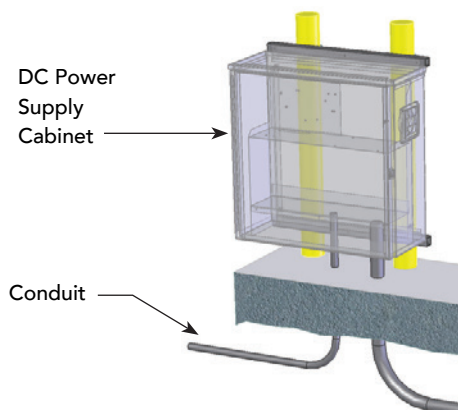

If you have a gate operator with a DC Power Supply unit, you will need to connect the primary AC input power to the DC Power Supply.

Additional 2-inch (5 cm) conduit is needed for electrical wiring interconnections between the HydraSupply XL and DC Power Supply cabinets. AC input power is connected to the electrical components in the HydraSupply XL and additional wiring is run through conduit to the DC Power Supply Cabinet.

A supplemental manual (MX3645-01), shipped with the DC Power Supply with HyCharger DC, provides further information.

Initial Setup

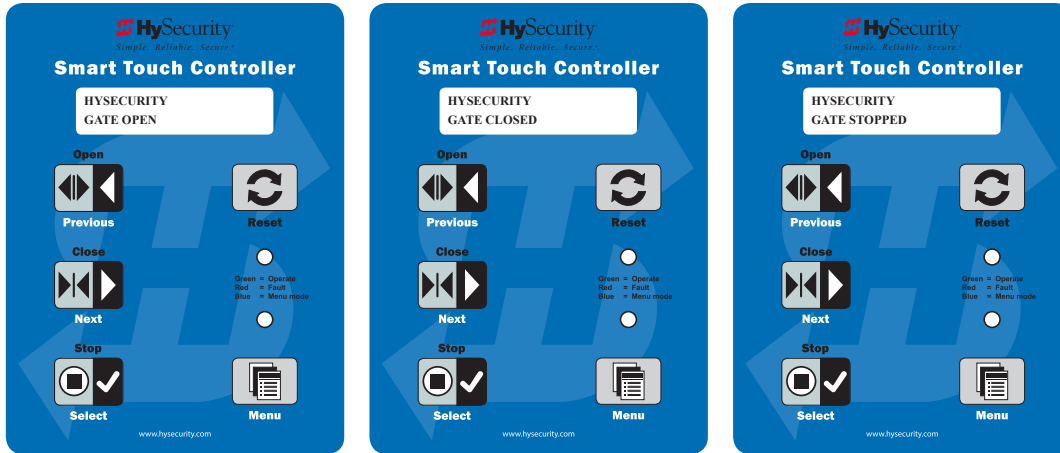

Gate Status Displays

In most instances, when you first apply power to the operator, a status display such as GATE STOPPED will appear on the display indicating the barrier gate is ready for use.

NOTE: At bi-parting (dual gate) sites, the operator is locked in Menu mode and prompts appear on the display. The gate will not move and the controls will not function until the prompts have been answered. The installer must specify the dual gate type. See “Table 10: INSTALLER Menu HydraSupply XL” on page 38.



Before turning the power switch to ON, be sure to replace the yellow vent cap with the breather cap. See page 16. Make sure all site requirements concerning proper wiring, safety, foundation installation, and electrical power have been met.

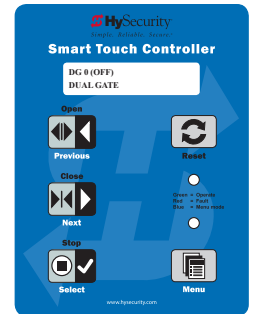

Five buttons on the display keypad provide operational controls. For more information, see “Display & Menu Options” on page 31. To answer the initial prompts, use the Previous, Next, and Select buttons as described in Table 4.

Table 4: Smart Touch Controller Menu Mode Navigation Buttons

To change that data appearing in the display	To navigate through the Selections	To choose what appears on the display	To navigate between menu items
Press Select . Two left characters blink.	Press Next . Continue pressing Next to view all selections. (Press Previous to reverse direction.)	Press Select . Blinking characters become static.	Press Next or Previous . Advance - press Next Previous - press Previous

The HydraSupply XL is UL 508A approved and therefore does not fall under the external monitored entrapment protection required by UL 325 Standard of Safety. However, HySecurity highly recommends assessing your site and providing the necessary safety equipment and precautions.

NOTE: For more information regarding HySecurity gate operators and UL 325 Standard of Safety, refer to the Quick Start - Supplement publicly available at [Gate Safety: HySecurity Website](#)

GROUNDING, BREATHER CAP INSTALLATION & HANDING

The barrier gate operator has a vent plug that keeps the hydraulic fluid from spilling during shipment. The vent plug must be replaced by the breather cap before operating the equipment.



Failure to perform the following procedure will cause premature pump shaft failure and void the Warranty.

1. Remove the yellow vent plug and discard it.
2. Replace the yellow vent plug with the breather cap.

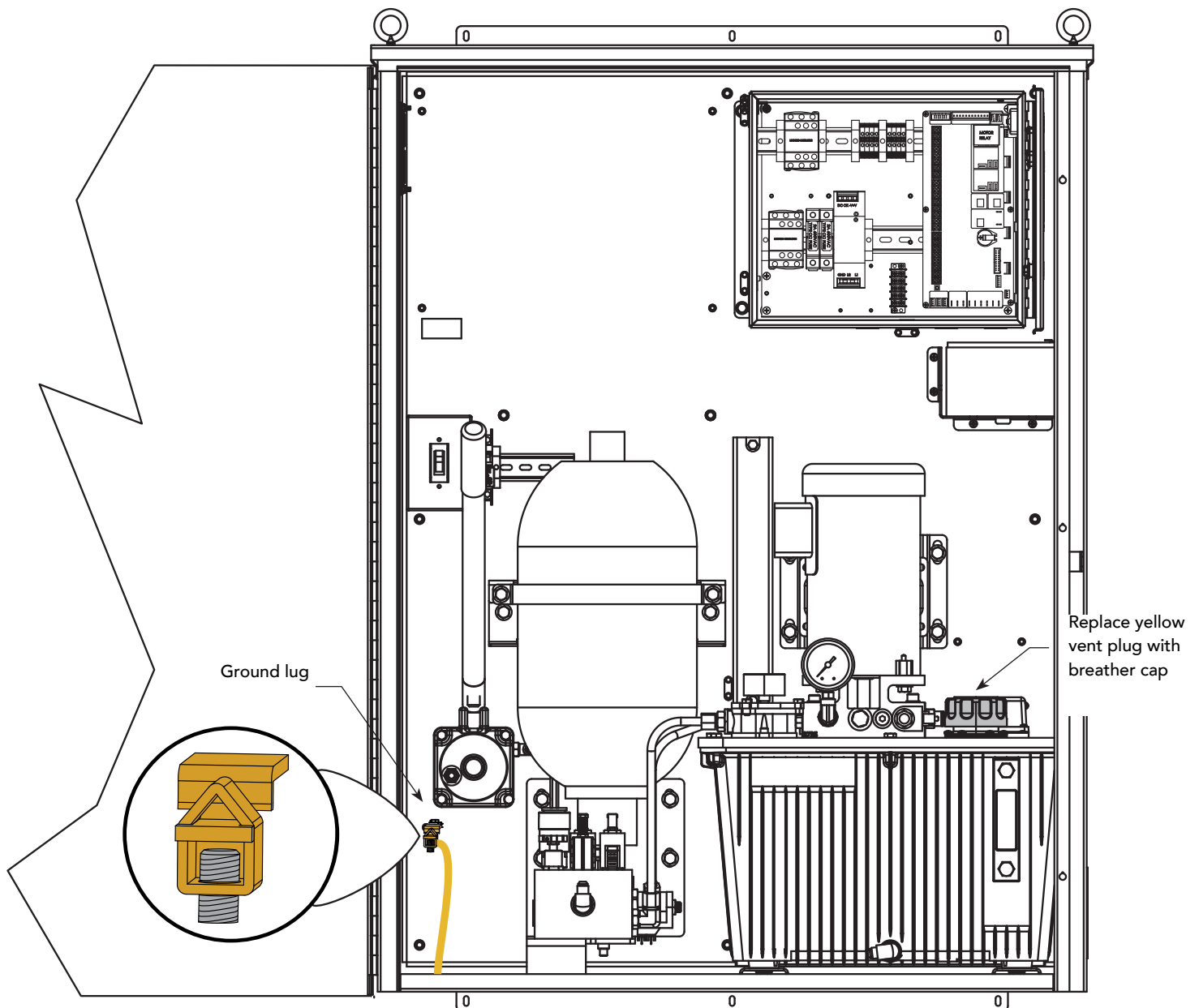

INSTALLING A PUSH BUTTON EMERGENCY FAST OPERATE (EFO) SWITCH

Hardware: The Emergency Fast Operate is intended to be activated remotely by control consoles with constant hold. On the HydraSupply XL, Terminal 23 is labeled EFO 1 and Terminal 24 is labeled EFO 2.

Software: Emergency Close (OC) has been factory set at 1 which, when EFO is activated, overrides all vehicle detector loops, all safety non-contact and contact sensors, and closes the blocking plate within 1 second.

The Smart Touch Controller logs the activity of the EFO inputs connected to the remote control consoles. To view log history, see "Access the Event Log through the User Menu" on page 58.

NOTE: The emergency close inputs are monitored, but do not cause the motor control relay or any valve outputs to energize (turn on). Open Valve and Close Valve output are turned off and the buzzer continues to be audible until EFO Reset (Terminal 13) is activated or 5 minutes elapses.

Emergency Fast Close Speeds

Operator	Close Speed
HydraWedge SM50	1 second

EFO CONNECTIONS: WIRING DIAGRAM

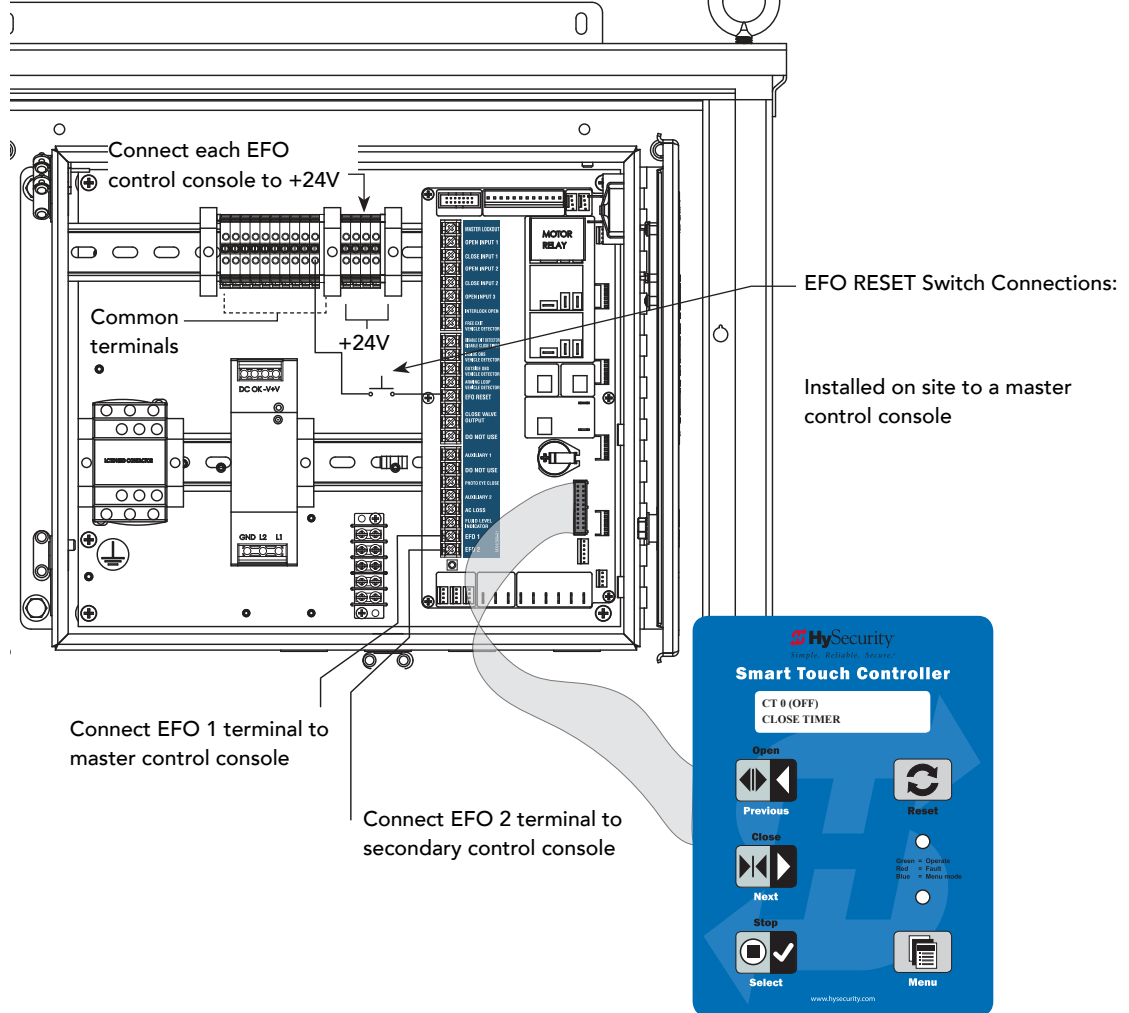

INSTALLING AN EMERGENCY FAST OPERATE (EFO) RESET SWITCH PUSH BUTTON DEVICE

As an enhanced safety mechanism, when the Close Limit is reached, the software enters Entrapment Mode and the barrier gate will not operate until Entrapment Mode is reset which requires that the emergency close input, EFO 1 and EFO 2 (Terminal 23 or 24) be de-energized and the EFO Reset input (Terminal 13) be triggered (activated) and released.

The EFO RESET switch must be wired from Terminal 13 to the Master control console and back to COM. See "EFO Connections: Wiring Diagram" on page 17.

EFO RESET Switch

Connect Master Control Console to Terminal 13 (EFO RESET)
Run wire from Master Control Console to COMon

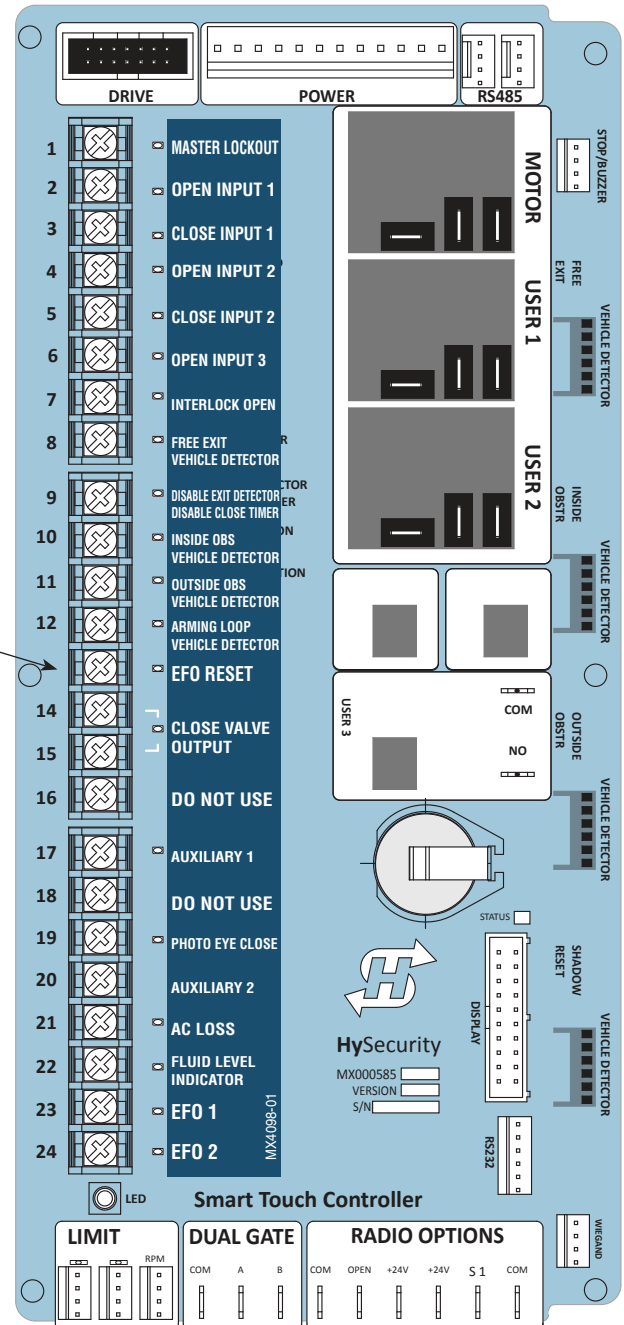

ACCUMULATOR PRECHARGE PROCEDURE

Use dry Nitrogen for precharging the accumulator.



DO NOT use air or oxygen. The accumulator could explode! Verify the gas valve is secure. Check the oil pressure gauge. It should read zero before precharging. Precharging the accumulator under pressure will result in accurate precharge pressure.

Table 5: Accumulator Precharge Pressure Values

Model	Motor hp	Nitrogen - Precharge PSI
HydraWedge SM50 with HydraSupply XL	2 hp	1500 PSI
HydraSupply XL (used only at retro-fit sites for power & controls)	5 hp	1500 PSI



Never exceed the maximum psi setting.

Take the following steps to precharge the accumulator.

1. Remove gas valve cap.
2. With the Nitrogen gas bottle valve closed, attach the charge kit hose to the gas bottle.
3. Attach gas chuck head to hose.
4. Back gas chuck stem all the way out before attaching gas chuck to the accumulator gas valve.
5. Attach gas chuck to accumulator valve and tighten swivel nut until hand tight. Lightly hand tighten 1/2 turn clockwise. DO NOT tighten with a wrench as the gas valve may twist off. Verify the bleeder valve is closed.
6. Turn gas chuck stem all the way down (CW) which depresses the accumulator valve core.
7. Gently turn the Nitrogen gas bottle valve toward open to slowly fill the accumulator. Shut off when gauge reaches desired precharge pressure.

NOTE: If you exceed the precharge pressure. Close the Nitrogen gas bottle. Then, open the bleeder valve slightly until pressure is reduced to the proper precharge.

8. Before loosening the gas valve swivel nut, turn gas chuck stem out all the way (counter clockwise) and then, open bleeder valve.
9. Gently turn entire gas chuck counter clockwise to loosen threads. Then, turn swivel nut to remove gas chuck from the accumulator gas valve.
10. Replace gas valve cap.

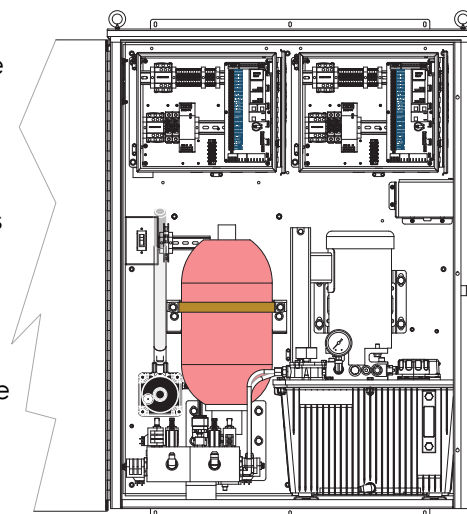

Twin HydraSupply XL

Page intentionally left blank

Bi-Parting & Dual Gate Systems

Configuring two or more operators to work together as an interlocked pair (Primary/Secondary or Sally Port) or sequenced gate system is easy to do with the Smart Touch Controller. The area of the board marked Dual Gate employs a 3-wire RS-485 serial port for communication between the operators.

NOTE: RS-485 communication is available for networked security systems. For additional information, refer to *"Integrating with Security Systems"* on page 45.

CONNECTING AN INTERLOCKED PAIR (DUAL GATE)

The Smart Touch Controller (STC) provides dual gate connections and programming features to connect a pair of gate operators in a Primary/Secondary or interlocked Sally Port configuration. The software establishes the communication protocols when wiring the two gate operators. A Primary/Secondary pair of operators can be set for different open/close timing sequences and Sally Port gates are often used at correctional facilities. In Sally Port configurations, one operator cannot open unless the other is fully closed. To learn how to connect the wiring between operators, review the wire diagram on the next page.

NOTE: Both HydraSupply XL gate systems need to have compatible software versions installed on their Smart Touch Controllers.

Dual Gate Wiring Connections

To connect an interlocked pair of gate operators, simply follow the steps below.

1. As shown in the Wire Diagram, connect a shielded communications cable to the DUAL GATE inputs in each operator. The inputs are located near the base of the Smart Touch Controller. Be sure to connect the wires in pairs to the same terminal ports (A-A, B-B, COM-COM) on both operators.
2. Attach a ring terminal to the shield wire and connect it to the Smart Touch Controller's convenient ground screw.



Connect the ground shield wire to only one operator, not both. Use only 18-20 gauge twisted and shielded wire. To operate properly, both Smart Touch Controllers must be using the same software version.

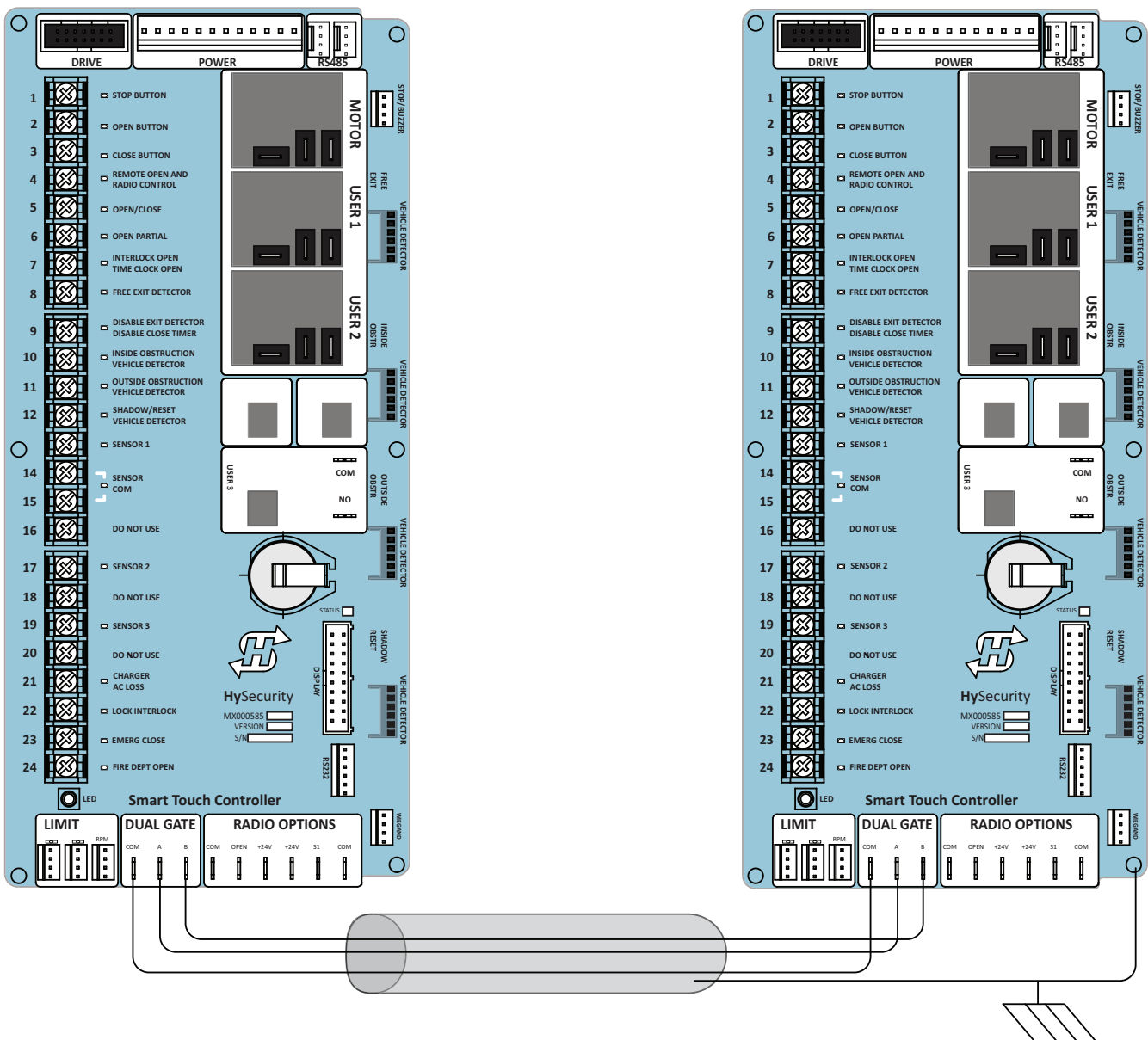

Wire Diagram: Interlocked Pair of Operators wired to DUAL GATE Inputs

Dual or Sequenced Gates: Power, Software & Accessory Requirements

When installing an interlocked pair, the following must be adhered to:

- An electrical conduit for interconnecting wires must span between the two operators. The interlock (dual gate) RS-485 communication wires and any low voltage control wires must be installed in a conduit that is separate from the high voltage power cables.
 - Complete the installation of both operators as separate machines and verify that their basic functions are correct as solo operators before interconnecting them.
 - Be sure both operators are running the same software. The software version can be viewed on the display by pressing the RESET button.
 - External control inputs (vehicle detectors and external entrapment protection sensors) may be connected to either gate operator in a Primary/Secondary configuration, but in a Sally Port configuration, each gate operator controls only those devices wired to it.
- NOTE:** If using the Hy8Relay on a Primary/Secondary dual gate system, connect it to the dual gate spades on the Primary controller.

Programming a Dual Gate (Interlocked Pair)

Both gate operators must be programmed so they know what function they are to perform as Primary and Secondary or Sally Port A and Sally Port B. (Sally Port A most often being the first gate to open for incoming traffic.) The Installer Menu provides the Dual Gate (DG) menu item that sets up the functionality of the gate operators. Access this menu item by taking the following steps:

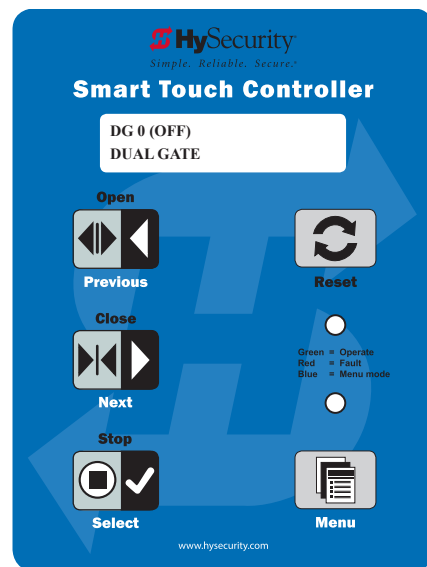
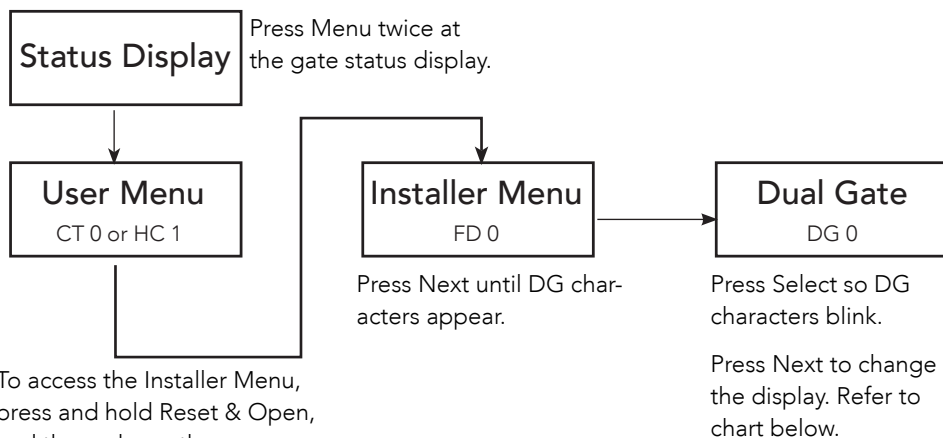

Refer to the Table 6 below to set the operator’s functionality. Refer to “Table 10: INSTALLER Menu HydraSupply XL” on page 38.

Interlocked Gate type	Operator 1 (Primary)	Operator 2 (Secondary)
Sally Port	Press Next until DG 3 appears on the display. Press Select to establish the operator as Sally Port A.	Press Next until DG 4 appears on the display. Press Select to establish the operator as Sally Port B.
Primary / Secondary Synchronous: 2 HydraSupply XL	Press Next until DG 2 appears on the display. Press Select to establish the operator as Primary.	Press Next until DG 1 appears on the display. Press Select to establish the operator as Secondary.

Table 6: Dual Gate Installer Menu Settings		
Interlocked Gate type	Operator 1 (Primary)	Operator 2 (Secondary)
Primary / Secondary Asynchronous 1 HydraSupply XL / 2 Controllers	Set MN to 2 Press Next until DG 5 appears on the display. Press Select to establish the operator as Primary.	Set MN to 2 Press Next until DG 6 appears on the display. Press Select to establish the operator as Secondary.

CONNECTING SEQUENCED GATES

Sequenced gates are slightly different than dual or interlocked gates. Usually, when two gate operators are connected as sequenced gates, a faster “Traffic Control Gate” operator and a slower “Security Gate” operator operate in sequence to help prevent tailgating or unauthorized entry. Both operators open (Security Gate first followed by the Traffic Control Gate) and allow a vehicle through, but the faster moving Traffic Control Gate closes quickly once its reset/center loop and all obstruction loops are cleared. Upon reaching its closed limit, the Traffic Control Gate signals the Security Gate to close. Note that all shared vehicle detector loops must be cleared before the Security Gate closes.

NOTE: An emergency open or close overrides the gate sequencing and acts upon both gates simultaneously.

The Smart Touch Controller (STC) provides the sequenced gate connections and programming features, and the STC software establishes the communication protocols when wiring the sequenced gate operators. To learn how to connect the wiring between operators, review the Wire Diagram below.



The operators do not have to be of the same type, but both need to have identical software versions installed on the Smart Touch Controller. For example, a StrongArm can be sequenced with a HydraWedge SM50 to provide both personnel security and crash provisions. The inherent STC software integrates seamlessly between operators and software protocols and allows RS-485 communication for networked security systems. Refer to “Integrating with Security Systems” on page 45 for additional information.

To connect a sequenced pair of gate operators, follow the steps on the next page.

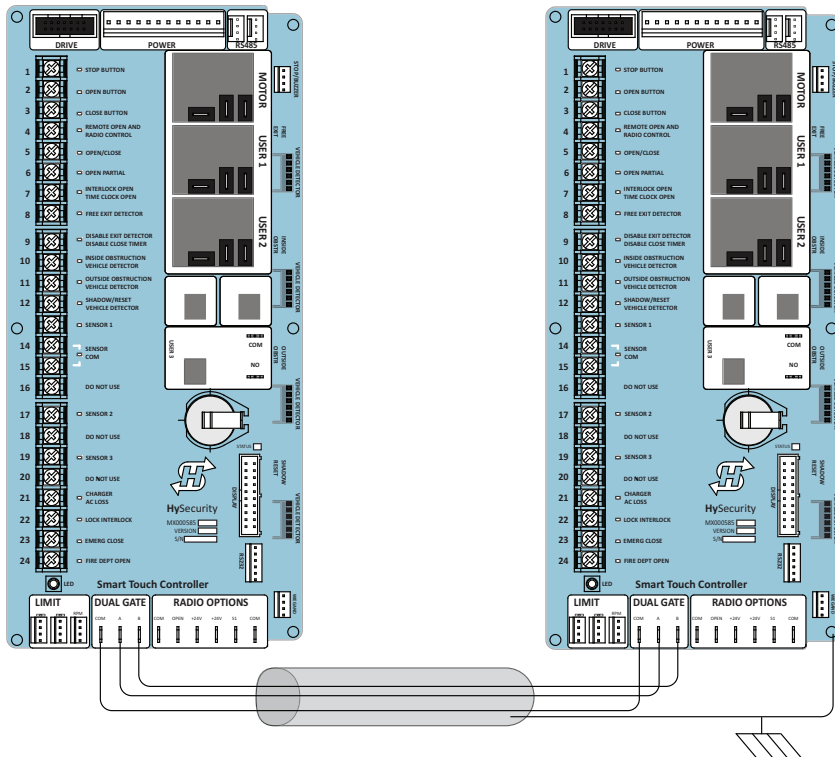

Wire Diagram: Sequenced Pair of Operators wired to DUAL GATE Inputs

1. As shown in the wire diagram on page page 25, connect a shielded communications cable to the DUAL GATE inputs in each operator. The inputs are located near the base of the Smart Touch Controller. Be sure to connect the wires in pairs to the same terminal ports (A-A, B-B, COM-COM) on both operators.
2. Attach a ring terminal to the shield wire and connect it to the Smart Touch Controller's convenient ground screw.

NOTE: Connect the ground shield wire to only one operator, not both. Use only 18-20 gauge twisted and shielded wire.

Sequenced gates are very similar to dual gates (interlocked pair) in their Power, Software, and Accessory Requirements. To review the installation site requirements, refer to "Dual or Sequenced Gates: Power, Software & Accessory Requirements" on page 23.

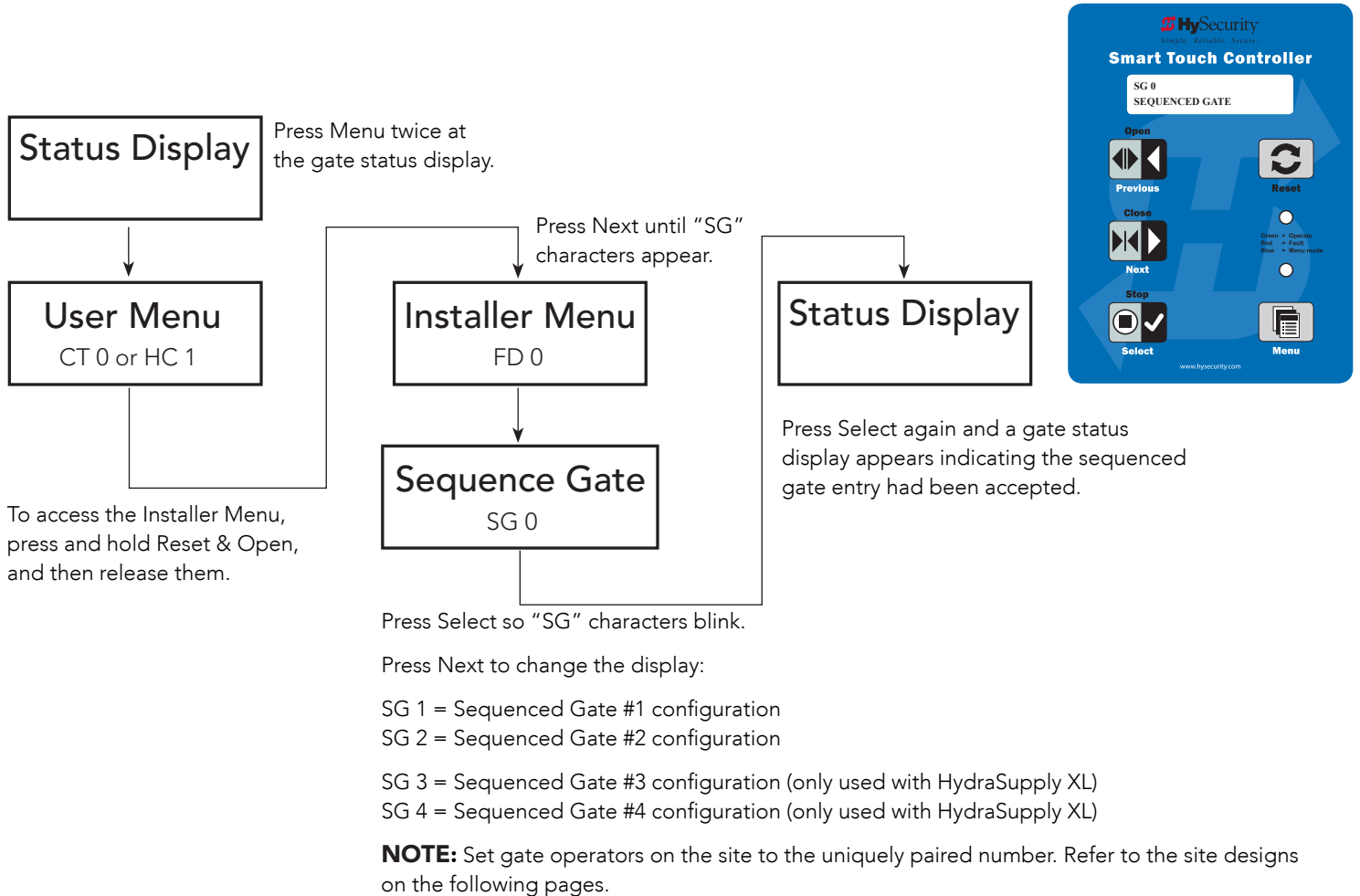

SEQUENCED GATE 1: STRONGARM M30 & HYDRAWEDGE SM50 SM50

Vehicle Loop Layout: SG 1

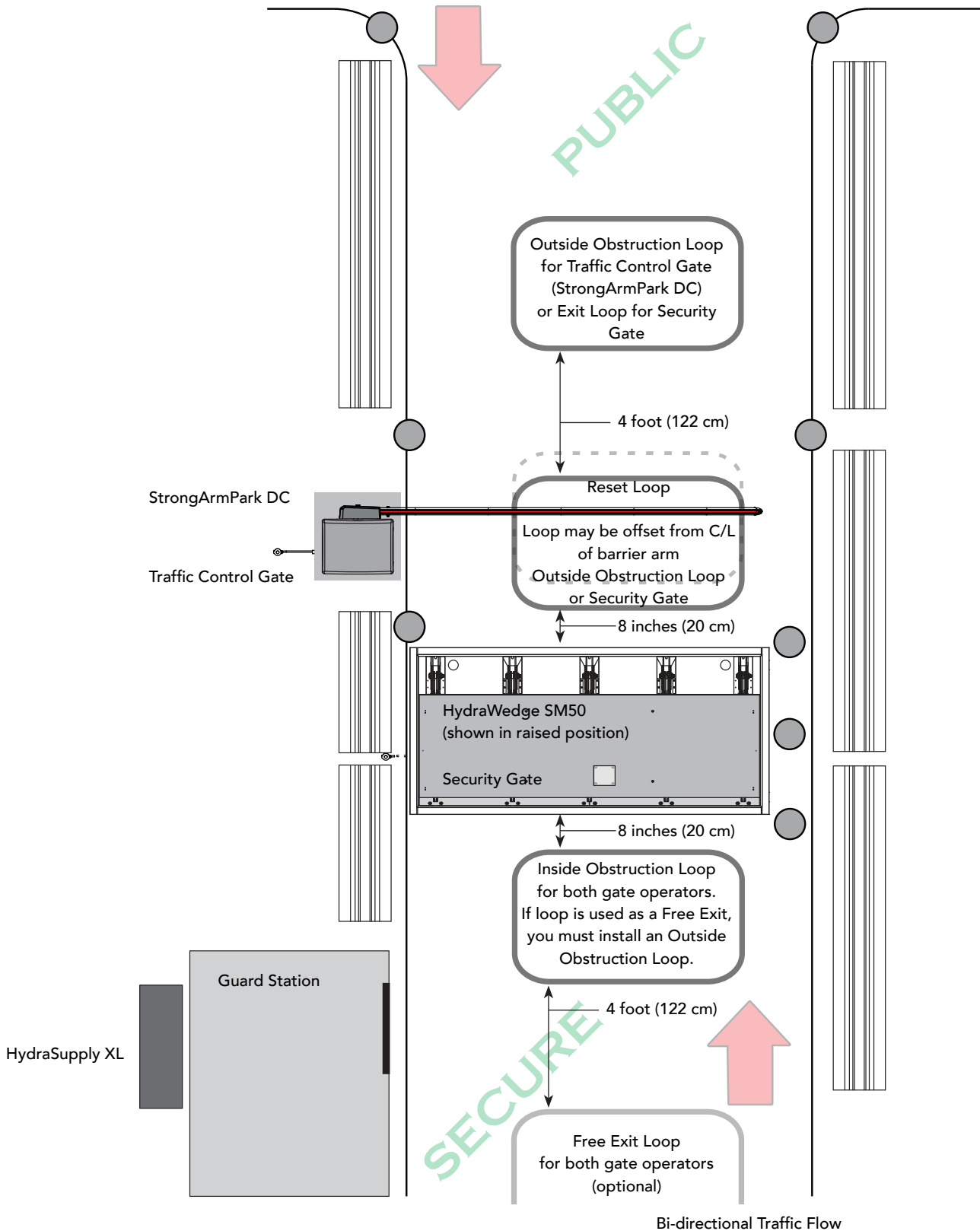

Drawings not to scale.

SEQUENCED GATE 2: STRONGARM M30 & HYDRAWEDGE SM50 SM50

Vehicle Loop Layout: SG 2

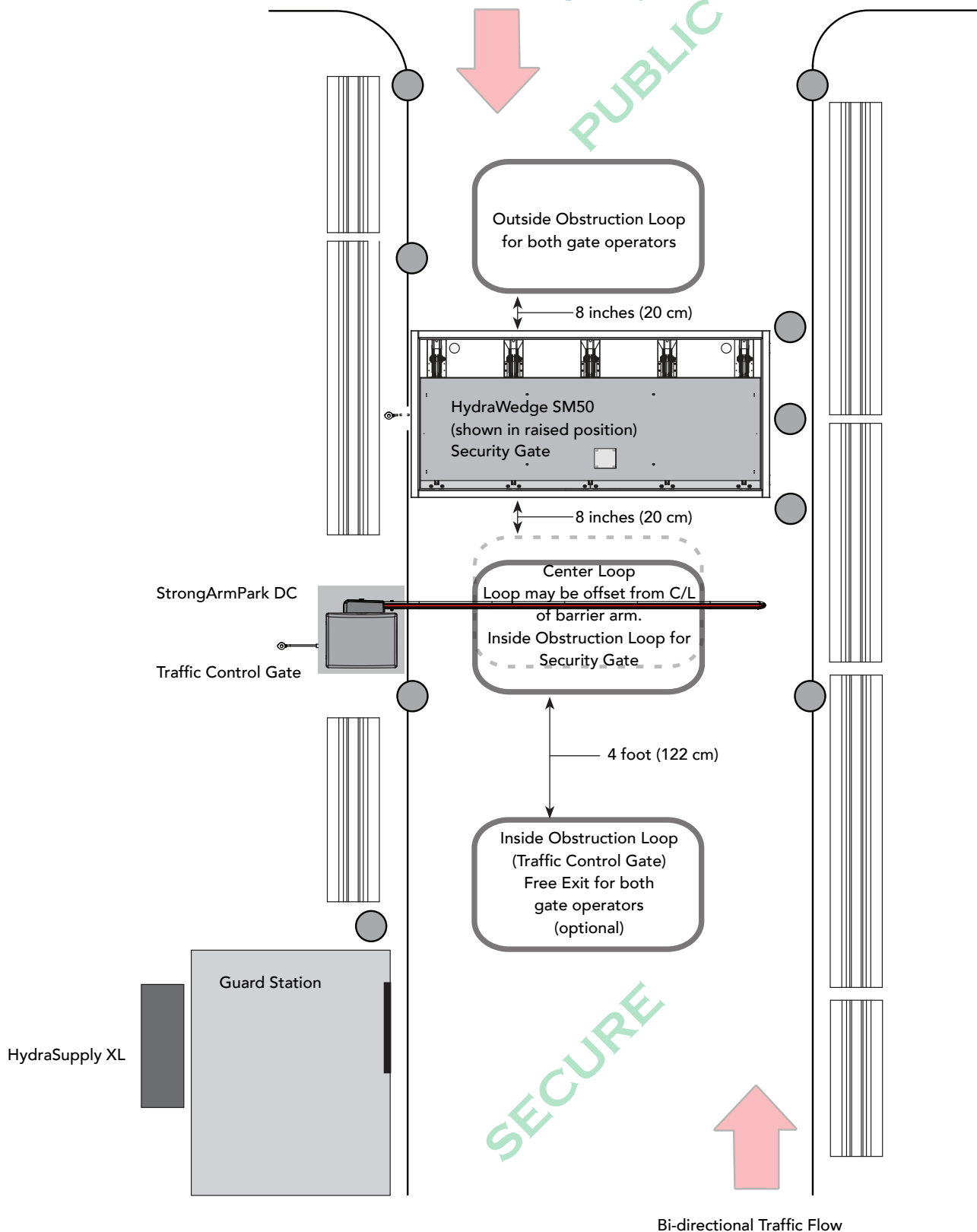

Drawings not to scale.

SEQUENCED GATE 3: SLIDE DRIVER & HYDRA WEDGE SM50

Vehicle Loop Layout: SG 3

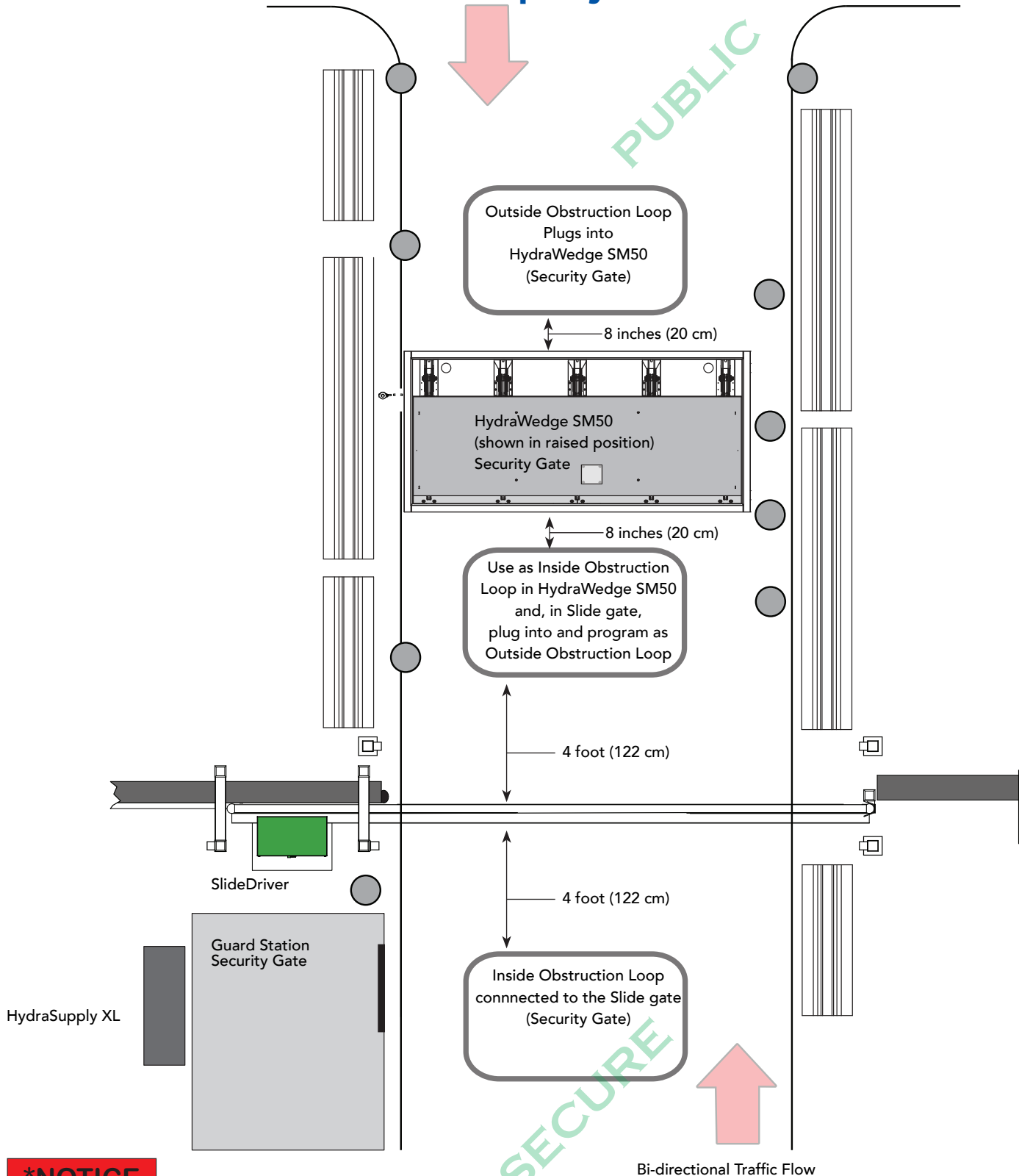

***NOTICE**

Loops may be plugged into either gate operator's controller.
If a communication failure occurs, an ALERT 22 (AL 22) appears and the buzzer sounds.

SEQUENCED GATE 4: SLIDE DRIVER & HYDRA WEDGE SM50

Vehicle Loop Layout: SG 4

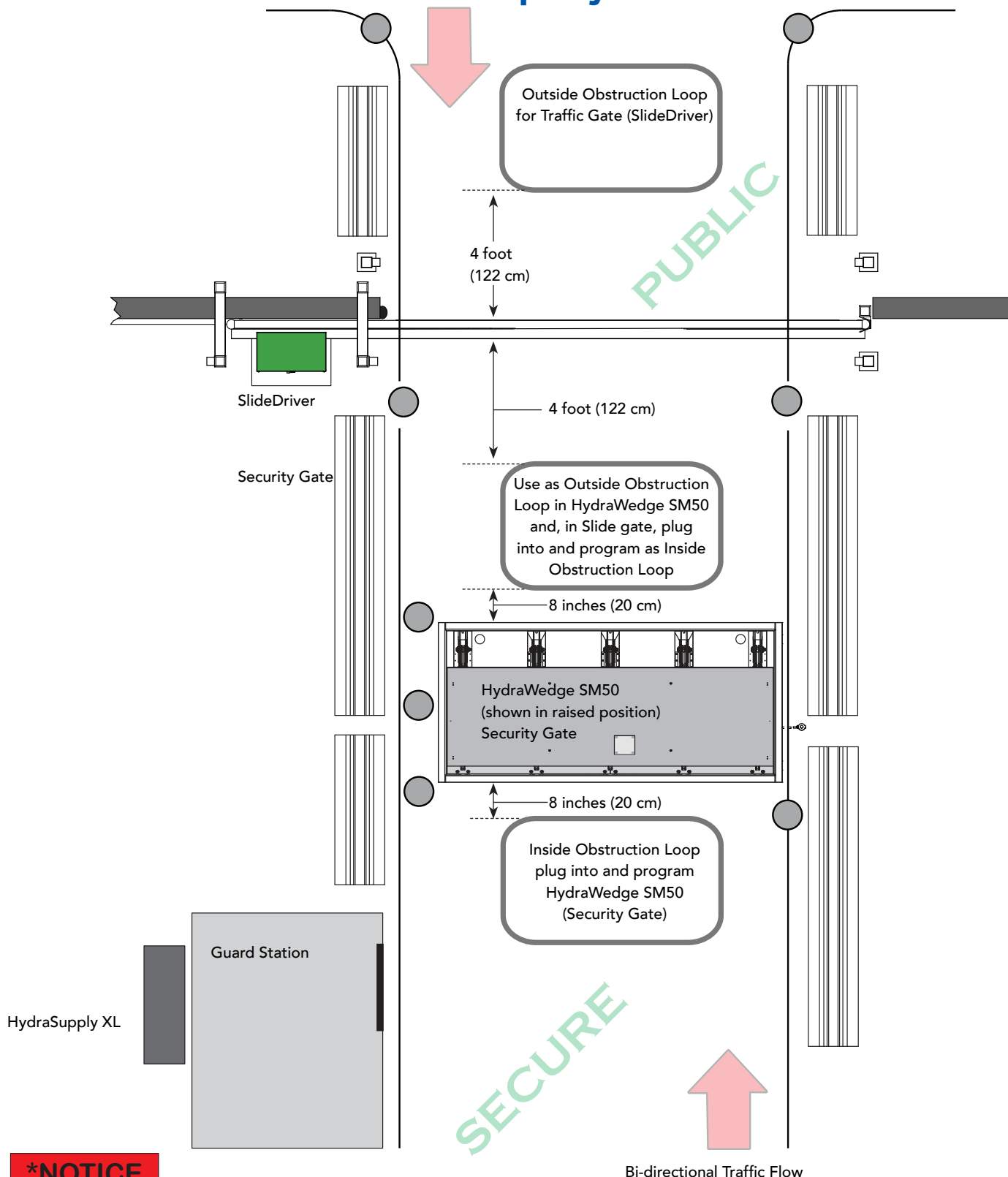

***NOTICE**

Loops may be plugged into either gate operator's controller.
 If a communication failure occurs, an ALERT 22 (RL 22) appears and the buzzer sounds.

Page intentionally left blank

Display & Menu Options

Highly sophisticated software provides three different modes of operation: *run*, *program*, and *fault*. How to navigate using the Smart Touch Controller (STC) keypad, interpret status display codes and program the operator is found in this section.



Gate operator software is updated on occasion. Check www.hysecurity.com for latest software releases.

INITIAL SETUP

Once you have completed the installation, attached the wired control panels, accessories and vehicle loops, and turned the power ON, you're ready to program the operator. Two different approaches exist:

- Connect a laptop computer to the serial (RS-232) port, check for the most current software version and then set the operator menu configurations via the S.T.A.R.T software.

NOTE: Use a laptop computer at your place of business to conveniently download the free START software and most current software version from www.hysecurity.com before heading out into the field. This makes it easy to adjust settings using a laptop.

- Manually navigate through the User and Installer Menus using the STC keypad. The instructions for performing this second option are provided in this section.



UNDERSTANDING THE DISPLAY AND KEYPAD

The STC display and keypad provide access to the operator's sophisticated software and functionality.

Three different operational modes exist:

- Run Mode – gate is operational, awaiting commands.
- Menu Mode – motor disengages and operator commands are ignored. Data entry, menu navigation, and menu selection can be accomplished via the keypad or through a START software connection using the RS-232 port.
- Fault Mode – alerts, faults, or errors appear on the display. Some errors or faults can be reset with the Reset button while more serious faults require additional troubleshooting. Fault mode indicates a need for diagnosis and resolution. Refer to "Troubleshooting" on page 53.

The keypad lets you navigate, change, or clear the information in the display menus. The singular use of these keys is dependent on the operator mode. The buttons with text above and below have two functions. Use these buttons to enter operating commands or navigate through the User and Installer Menus.

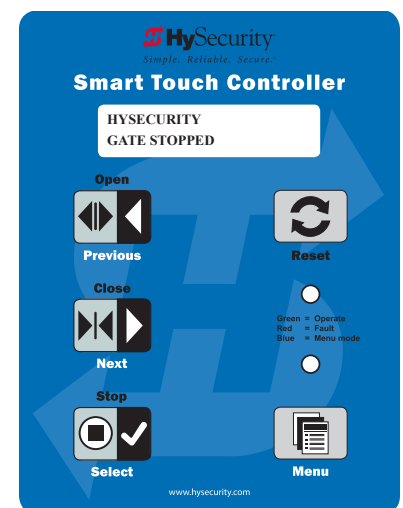

Gate Status Display in Run Mode

MENU MODE AND THE STC KEYPAD

In Menu Mode, the motor disengages and operator commands are ignored. Data entry, menu navigation, and menu selection can be accomplished using the buttons on the Smart Touch Controller keypad.

NOTE: Menu Mode automatically returns to Run Mode if no activity (i.e. key presses) occurs for two minutes.

Two blinking characters indicate that the display will accept changes.

Next or Previous
Navigational buttons. Pressing Next or Previous scrolls through the selections.

Pressing **Select** causes the left most two characters to blink, (CT in the example), which indicates the display is ready to accept changes to a menu setting.

Use the navigational buttons to view selections. Press **Select** a second time to accept what appears on the display. Entry mode is exited, the two characters stop blinking, and Next or Previous must be pressed to move onto a different display. Pressing Menu exits to Run mode.

32-character display provides information about the menu items.

The **Reset** button is disabled while in Menu Mode.

LED	Function
Green	= Run/Operate
Red	= Fault Mode
Blue	= Menu Mode

The **Menu** button accesses Menu mode. When the menu item is selected and blinking, the Menu button has no function. However, pressing Menu when the 2 characters are static (not blinking), returns the operator to Run Mode.

MENU MODE NAVIGATION

Navigating within the program menus is easy once you learn how the keypad buttons function. Refer to the following chart.

Table 7: Smart Touch Controller Menu Mode Navigation Buttons

To change menu item appearing in the display	To navigate through the menu item selections	To choose item that appears on the display	To navigate between menu items
Press Select . Two left characters blink.	Press Next or Previous . Continue pressing Next to view all selections.	Press Select . Blinking characters become static.	Press Next or Previous . Advance - press Next Previous - press Previous

RUN MODE AND THE STC KEYPAD

The Run Mode displays appear static when the operator is ready and waiting for a run command. When the display is flashing GATE OPENING or GATE CLOSING, a command has been received and the barrier gate is in motion. The command may come from a variety of sources: a card reader, push-button remote, or recognition of a vehicle passing over a loop detector. In all cases, the operator “runs” the motor when it receives an operational command.

Three displays indicate the position or status of the gate. The keypad entry used to access the User or Installer menus, begins at one of these Run Mode displays.

32-character display identifies operator status.

Pressing Open, Close, or Stop causes the gate to perform the command.

Pressing **Reset** clears alerts or faults and returns to Run Mode. **NOTE:** Press Reset at any Run mode status display to view the software version. For example: **h4.55**

Pressing **Menu** scrolls through operator status displays and accesses the User Menu. **NOTE:** Pressing the Menu button twice, bypasses the operator status displays.

Run Mode Displays

NOTE: To access the User or Installer menus, the motor cannot be engaged and the gate cannot be moving.

VIEWING OPERATOR GATE SCROLLING STATUS

Press the Menu button once and the operator status displays scroll past in two second intervals. Pertinent information appears to provide a quick overview of the operator’s status or configurations.

The type of information that may scroll across the display includes: interlocked or sequenced gate (if applicable), operator type (OT), Usage Class (UC), buss voltage, and life cycle counter.

Example of Operator Status Displays

The following table describes the scrolling status displays in the HydraSupply XL models.

Operator Status Display	Variables	Description
Dual Gate or Sequenced Gate	This display only appears when the operator is used in interlocked or sequenced gate systems and indicates the function of the operator. <i>"Bi-Parting & Dual Gate Systems"</i> on page 21.	Indicates, in an interlocked or dual gate setting, whether the operator is set to Primary or Secondary or Sequenced Gate configuration. The setting is assigned in the Installer Menu.
Operator Type (OT)	OT 10 = HydraSupply XL	Indicates and identifies the operator.
Usage Class (UC)	1, 2, 3, or 4	Displays the operator's Usage Class designation per UL 325 standards. In the case of the UL 508A compliant HydraSupply XL and other CRASH barrier and gate operators, the usage class is automatically set to 4.
Input Voltage VDC	The number varies depending on the voltage that the power supply is providing.	Input voltage (DC Buss voltage) to the STC is shown. Helps to determine proper power connections.
Cycle Count (CC)	One cycle equals a full open and close sequence. Increments every time the open limit is reached.	Displays the number of cycles the gate operator has incurred. Similar to an odometer, it resets to zero after 999,999 cycles.
Close Timer (CT)	The first menu item in the User Menu.	Displays the number of seconds before the open gate initiates closure. NOTE: You can also access the Installer Menu from this display.

Stop the Status Display Scrolling

To stop the operator status display scroll and focus on one item, press Select. Press Select a second time, to resume the scrolling display.

Change the Contrast on 7 Segment Displays

NOTE: Since sunlight does not affect readability on the OLED display, changing the display contrast is not available on models shipped with the 32 character display.

While the operator status displays are scrolling, you can change the contrast by pressing the up or down arrow keys. The display's contrast changes accordingly.

Check the Software Version

Press Reset. The display indicates the software version loaded on the gate operator. To upload software, you will need a PC laptop. For more information, see *"Smart Touch Analyze and Retrieve Tool (S.T.A.R.T.)"* on page 59.

Check Time and Date

An easy way to determine if your operator is set for the correct date and time zone can be accomplished by taking the following steps:

1. While in Run mode (gate status appears in the display), press and hold the STOP button.
The date DD/MM and time HH:MM appears.
2. If you need to account for the time zone, refer to the Set Clock "CL" item in the User Menu. Refer to *"Table 9: USER Menu HydraSupply XL"* on page 36.

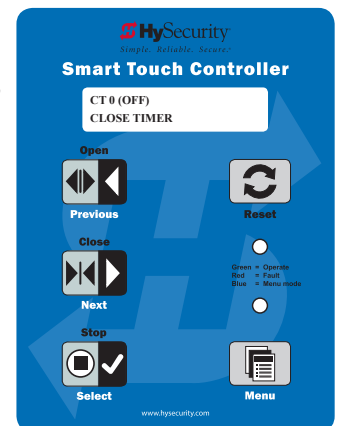

USER MENU

The User Menu consists of several items which can be modified using the Smart Touch Controller keypad.

Access:

Pressing the Menu button, at one of the static gate status displays, causes the operator status displays to scroll past, stop and display the first user menu item.

When the CT, Close Timer (or HC, Hold to Close) display appears, it means you have accessed the User Menu. The Close Timer display is the first in a cyclical series of User Menu displays.

NOTE: To access the User Menu, the operator must be in Run Mode. To bypass the operator status displays, press the Menu button twice.

Use the navigational buttons, Select, Next, and Previous to change or view the menu functions. Refer to "Table 7: Smart Touch Controller Menu Mode Navigation Buttons" on page 32

"Table 9: USER Menu HydraSupply XL" on page 36 describes the User Menu items and supplies the factory defaults. (Factory default settings shown in bold.)

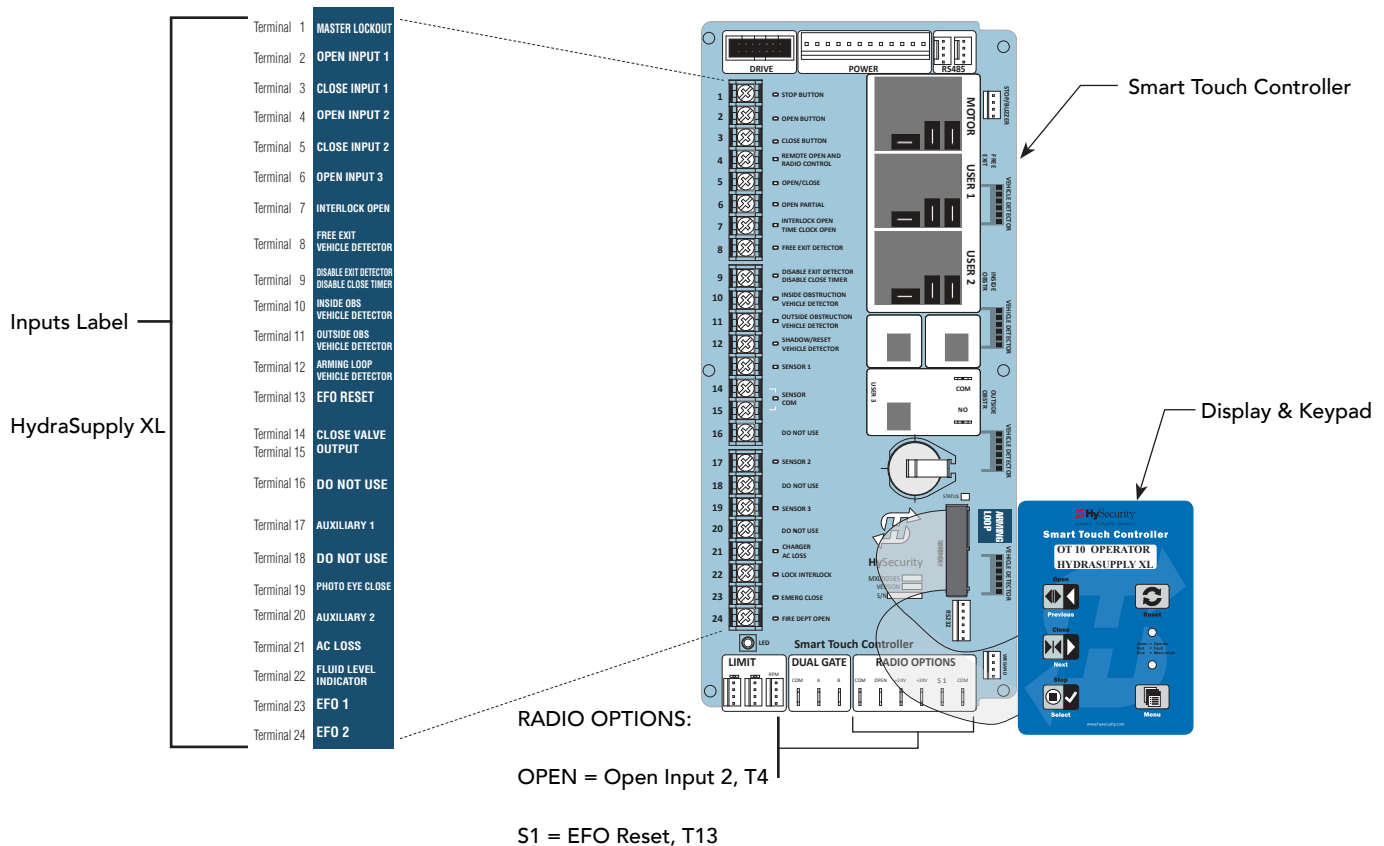

TABLE 9: USER MENU

Table 9: USER Menu HydraSupply XL				
	User Menu	Setting Options	Menu Tasks & Explanations	STC Wire Connections
1	CT 0 (OFF) CLOSE TIMER	0 = Timer disabled (OFF) 1 second to 99 seconds	The Close Timer assigns how many seconds before the open gate initiates closure. It provides a security precaution in case a CLOSE pulse is missed. Keep the setting at 0 if a hard-wired, push-button control device is being used. Refer to HC. NOTE: When the Hold to Close is set to 1 or more seconds, the Close Timer display does not appear and HC 1 becomes the User Menu entry display.	Not applicable (N/A)
2	HC 0 (OFF) HOLD TO CLOSE	0 = off 1 = on	The default setting of 0 produces a gate closure when a momentary signal is transmitted. 0 = Momentary open signal 1 = Requires constant "hold to close" contact, such as a push button connection to a console or panel. NOTE: A setting of 1 deactivates the automatic close timer and causes its menu item to disappear from the display choices. The Hold to Close (HC) replaces the Close Timer (CT) display as the User Menu entry display.	COM Close
3	HO (OFF) HOLD TO OPEN	0 = off 1 = on	Similar to Hold to Close, but configures the Open inputs. 0 = Momentary open signal 1 = Requires constant "hold to open" contact, such as a push button connection to a console or panel.	COM Open
4	AP 0 AC LOSS	0 = UPS FAIL OPEN 1 = UPS FAIL CLOSE 2 = AUTO OPEN 3 = NO CLOSE TIMER	Appears on DC powered operators only. The setting configures how the gate functions when AC power fails. For more information, see the supplemental documentation that accompanies the HyCharger DC. HyInverter AC is not for use on the HydraSupply XL.	COM Terminal #21
5	BF 3 (ON DURING) WARN BEFORE OPER	0 = off 1 = warning buzzer on throughout gate travel 2 = warning buzzer on for 2 seconds of gate travel 3 = warning buzzer on during gate travel	Controls the warn-before-operate buzzer and can be configured three ways: Set to 0: Buzzer is disabled. The buzzer will still beep if alerts, faults, errors, or entrapment occur. Set to 1: Buzzer beeps for 3 seconds before gate moves and continues through entire length of travel. Set to 2: Buzzer beeps for 3s before gate moves and continues for 2s of travel. Set to 3: Buzzer beeps when gate starts to move and continues throughout gate travel.	Not applicable (N/A)
6	PE 0 (OFF) PHOTO EYE ALIGN	0 = off 1 = on	Set to 1, the operator serves as an aide in photo eye alignment. In the HydraSupply XL, the photo eye is not monitored as the SENSOR COM terminals 14 & 15 have been replaced by the CLOSE VALVE output. If the installer connects to Terminal 19 with a photo eye, it requires a normally open contact, since the HydraSupply XL falls under the Build Year 1 guidelines (even though it is manufactured in Build Year 2). If the operator doesn't run when the power switch is initially turned ON and a command is given, check the alignment of the photo eye and the photo eye connections.	Photo Eye Close +24 V COM
7	CL 0 SET CLOCK	0 = off 1 = on	To adjust the hour, minute, day, or month to a different time zone, select 1. Once the clock is set, press Menu. You exit the Set Clock Menu and the display returns to the 0 setting. It is important to adjust the clock for the operator's time zone because significant events are time and date stamped which provides historical operation data.	N/A
8	LG 0 (OFF) VIEW EVENT LOG	0 = off 1 = on	With v4.52 (or higher) version of software, set LG to 1 to view abbreviated event logs. These messages are helpful for diagnostic purposes and reviewing the gate operator's event history. Over 300 events can be logged before the software begins overwriting the oldest events. See "Access the Event Log through the User Menu" on page 58.	N/A

Table 9: USER Menu HydraSupply XL

	User Menu	Setting Options	Menu Tasks & Explanations	STC Wire Connections
9	DS 0 (OFF) DIAGNOSTIC LOGS	0 = off (standard) 1 = on (detailed)	Set to 0, the STC records pertinent operator events such as faults, errors, or menu manipulation. When experiencing intermittent problems, set this item to 1 to record all operator open and close events, in addition to the normal alert, fault and error logs. When set to 1, the reaction of the gate operator is delayed. The slowdown in operation occurs because the gate operator's microprocessor is recording a large volume of events. Be aware and use the # 1 setting sparingly. If the installer does not reset the diagnostic log to 0, the parameter automatically resets (standard default 0, pertinent data log) after a 24-hour period. With the Diagnostic Log set to 0, the automatic gate returns to normal operations.	To read the log file, see the User Menu item LG (available on software version 4.52 and higher). Alternatively, an RS-232 cable and PC laptop computer loaded with HySecurity free S.T.A.R.T. software can be used. Visit www.hysecurity.com
10	PD 0 SET PASSWORD	0 = Off 1 = On (Set Password)	A System Address (SA) value in the installer Menu must be set to a non-zero number before the Set Password display appears in the User Menu. To enter a password (up to 16 characters) for network connectivity, select a non-zero number. You can use the menu navigation buttons to enter the password. When the password is set/selected, the display returns to the 0 setting.	Network: RS-232 or RS-485 WinPC configuration

INSTALLER MENU

The Installer Menu items provide more advanced configurations for the gate operators. Access to the Installer Menu is through the User Menu. The navigational buttons are the same in both menu modes. Refer to "Menu Mode Navigation" on page page 32.

Access:

While a static gate status is being displayed, press the Menu button twice. (Bypasses the operator status displays.)

When the Close Timer display appears (Hold to Close, if the Close Timer display is hidden):

1. **Access the Installer Menu** by simultaneously pressing and holding the Reset and Open buttons.
2. Release both buttons and the display changes, indicating you have arrived at the first item in the Installer Menu.

NOTE: Installer Menu options can also be configured through the use of a laptop computer and S.T.A.R.T. software.

"Table 10: INSTALLER Menu HydraSupply XL" on page 38 describes the Installer Menu items and supplies the factory defaults. (Factory settings shown in bold.)

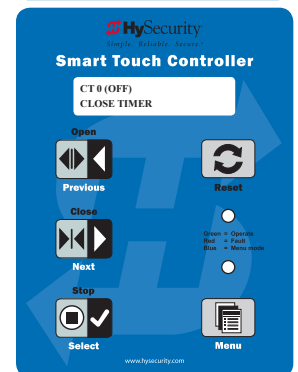
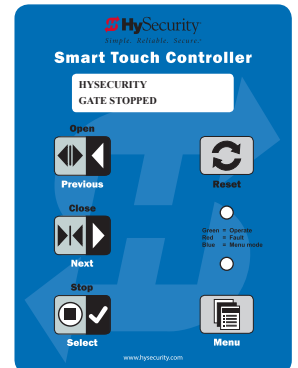

TABLE 10: INSTALLER MENU

Table 10: INSTALLER Menu HydraSupply XL				
	Installer Menu	Setting Options	Menu Tasks & Explanations	STC Wire Connections
1	MN 0 MODEL NUMBER MN 1 SET MODEL # SINGLE STC MN 2 SET MODEL # DUAL STC	0 = Disabled. 1 = One Smart Touch Controller exists in the HydraSupply XL. 2 = Two Smart Touch Controllers exist in one HydraSupply XL. **	Menu item only appears if it is not set at the factory. For example, when the Smart Touch Controller is being replaced. Model number appears on StrongArm CRASH, HydraSupply XL, HydraSwing, WedgeSmart DC, and StrongArmPark DC. For the HydraSupply XL (OT 10), the model number provides information about the site. Depending on site configuration and need, one Smart Touch Controller can operate 1 wedge barrier (solo). Two Smart Touch Controllers can also be housed in one HydraSupply XL. Each STC operates one wedge barrier. Settings: 0 = Disabled. No operation can occur until the model number is set to a non-zero number. 1 = One Smart Touch Controller, one motor exists in the HydraSupply XL. 2 = Two Smart Touch Controllers, one motor exists in one HydraSupply XL. If MN is set to 2, the operator remains disabled until the dual gate (DG) is changed to a non-zero value and communication with the other controller has been established. **NOTE: If using MN 1, the DG settings affords asynchronous operation, 5 and 6. See Dual Gates section on page page 21. When MN is set to 2, the Sequenced Gate (SG) Installer Menu item is hidden and unavailable.	N/A
2	FD 0 (CUSTOM) FACTORY DEFAULTS	0 = user settings (custom) 1 = reload factory settings	Setting 1 resets any custom programmed menu items to the factory defaults for the specific operator type. Changing FD to 1, globally restores all menu settings back to newly shipped operator condition.  Customized menu settings are lost and will need to be reprogrammed. Prior to resetting the gate operator's menu items to their factory floor defaults, you may save your customized menu settings using a PC laptop & S.T.A.R.T.	N/A
3	DG 0 (OFF) DUAL GATE	0 = solo operator (off) 1 = Secondary unit 2 = Primary unit 3 = Sally Port A 4 = Sally Port B 5 = Primary Controller in HydraSupply XL 6 = Secondary Controller in same HydraSupply XL	Establishes communication after wiring dual gate connections between two operators in Primary/Secondary or Sally Port site configurations. This menu item appears if the sequenced gate menu item (SG) is set to 0 (off). For HydraSupply XL settings 5 & 6 distinguish between controllers in an asynchronous operation scenario. The model number MN must be set to 2 for options 5 & 6 to appear. Designating DG as 0, means RS-485 communication is off and the system is not looking to establish communication with another gate operator.	Dual Gate COM (Gate 1) to Dual Gate COM (Gate 2) A to A B to B
4	SG 0 (OFF) SEQUENCED GATE	0 = off 1 = Loop Layout/Site #1 2 = Loop Layout/Site #2 3 = Loop Layout/Site #3 4 = Loop Layout/Site #4	Establishes communication after wiring two gate operators as sequenced gates. The SG menu item only appears if the Dual Gate menu item (DG) is set to 0 (off) and MN is set to 1. Loop Layout scenarios: 1 & 2 for use when sequencing wedge barrier (security control) with a barrier arm gate (traffic control) 3 & 4 for use when sequencing wedge barrier with a security gate For more information, see "Connecting Sequenced Gates" on page 24. After selecting SG settings, consider accessing the User Menu in each gate operator to address the Close Timer (CT) setting which will help ensure closure in the allotted time frame if using the barrier for traffic control.	Connect Dual Gate COM (Traffic Gate) to Dual Gate COM (Security Gate) A to A B to B
5	CH 0 (AC) CHARGER TYPE	0 = AC powered charger 1 = Solar powered charger	Default 0, Set at Factory CH, Charger Type ONLY appears on an DC-powered operators and allows for a designation of the solar charger type.	N/A

Table 10: INSTALLER Menu HydraSupply XL

	Installer Menu	Setting Options	Menu Tasks & Explanations	STC Wire Connections
6	EC 0 STOP ONLY EYE CLOSE LOGIC	0 = Photo Eye Close eye stops only 1 = Two second reversal to open on swing, slide, or vertical gates. Reverse to full open with barrier gates, StrongArm M30 and StrongArm M50.	On HydraSupply XL (OT 10), a Terminal 19 connection (Photo Eye Close) only accepts normally open inputs. If the close photo eye is triggered, the default setting is to stop with non-reversal while the barrier is raising (close direction of travel). With the optional setting of EC 1, the wedge's blocking plate stops and reverses to full open (roadway open), and then resumes moving close if the photo eye clears within 5 seconds	Photo Eye Close (Terminal 19) COM +24V
7	DT 0 FREE EXIT DISABLE FUNCTION	0 = Disable Free Exit 1 = Disable Close Timer	Configures DISABLE EXIT DETECTOR (Terminal #9) input to disable either the Free Exit Detector function or, alternately, the Close Timer function. The default setting disables the free exit detector. When set to 0, the free exit is disabled while the gate rests on its closed limit. If the closed limit is not tripped, the free exit continues to work normally.	DISABLE EXIT DETECTOR (#9) COM
8	OR 1 REVERSE OUTSIDE OBS LOOP	0 = Pause closing only 1 = Enable reversing to open 2 = Ignore and continue closing*	The default (1) is for full reversal when the Outside Obstruction Loop is triggered. A setting of 0 causes the gate to only pause when triggered. The gate closure begins as soon as the loop is clear again. *A setting of 2 is available on CRASH barriers and provides for the most secure facilities where it is essential that the loop trigger is completely ignored and the barrier continues closing without pause or reversal.	OUTSIDE OBS LOOP (#11) COM or connection to HY-5A detector
9	IR 1 REVERSE INSIDE OBS LOOP	0 = Pause closing only 1 = Enable reversing to open 2 = Ignore and continue closing*	The default is for full reversal when the Inside Obstruction Loop is triggered. A setting of 0 causes the gate to only pause when triggered. Closure begins as soon as the loop is clear again. *A setting of 2 is only available on CRASH barriers and provides for the most secure facilities where it is essential that the loop trigger is completely ignored and the barrier continues closing without pause or reversal.	INSIDE OBS LOOP (#10) COM or connection to HY-5A detector
10	DL 1 STANDARD DETECTOR LOGIC	1 = Standard 2 = Quick Close 3 = Immed Close (OOLD and IOLD tripped simultaneously)	Determines how the operator responds to vehicle detector activations. 1 = Standard closure logic. The Close Timer count down doesn't begin until loops are released. 2 = Quick Close When open limit reached, even though the loops are active, the Close Timer (CT) begins counting down. 3 = Immediate Close (When OOLD and IOLD are tripped simultaneously in either direction of vehicle traffic, the wedge's blocking plate closes when both loop inputs are cleared regardless of the Close Timer setting.)	STC Terminals: 10 through 12 COM Or connection to HY-5A detector
11	RL 1 CLOSE LIM RELAY 1 LOGIC	0 = Disabled 1 = Close limit active 1 to 32 available	Configures the function of the User 1 output relay. It has the capacity to switch both AC and DC loads and can be used for high voltage and/or high current loads. Connect devices directly to the top of the relay: COM and either NO and/or NC contacts. Multiple logic function options exist. See "User Relays - Programming Procedure" on page 48.	User 1 Relay
12	R2 6 GATE LOCK RELAY 2 LOGIC	0 = Disabled 6 = Gate Lock 1 to 32 available	Configures the function of the User 2 output relay. It has the capacity to switch both AC and DC loads and can be used for high voltage and/or high current loads. Connect devices directly to the top of the relay: COM plus NO and NC contacts. Multiple optional logic function options exist. Refer to "User Relays - Programming Procedure" on page 48.	User 2 Relay
13	R3 1 CLOSE LIM RELAY 3 LOGIC	0 = Disabled 1 = Close Limit 1 to 32 available	Relay 3 configures the function of the User 3 output relay, which is an electronic relay with the capacity for switching a DC load only.	User 3 Relay
14	R4 through R11 RELAY <n> LOGIC	0 = Disabled 1 to 32 available	Similar to Relay 1 Logic. The Hy8Relay™ module option can be purchased to provide an additional 8 relay terminals.	COM

Table 10: INSTALLER Menu HydraSupply XL

	Installer Menu	Setting Options	Menu Tasks & Explanations	STC Wire Connections
15	TL 2 (45 SECS) OPEN TIME ALERT	2 = 45 second delay 0 = 0s delay 1 = 15s 2 = 45s 4 = 105s 5 = 135s	Allows you to specify when the user relay that is programmed to Option 8 activates. The relay turns ON when the software detects that the gate operator has been off its close limit and not moving for the specified period of time. With newer software versions, TL appears in the Installer Menu even without the User Relay option 8 being utilized.	User Relay Option 8
16	LT 3 (75 SECS) LOITERING ALERT	3 = 75 second delay 0 = 0s delay 1 = 15s 2 = 45s 4 = 105s 5 = 135s	Allows you to specify when the user relay that is programmed to Option 13 activates. The relay turns ON when the barrier is closed and the software detects that the OOLD is active longer than the specified period of time. With newer software versions, LT appears in the Installer Menu even without the User Relay option 13 being utilized.	User Relay Option 13
17	SA 0 (OFF) STC ADDRESS	0 = (OFF) No network 1 to 99 = Network "drop" address	Sets the system address for network communication. 1 – 99 sets individual poling addresses. Refer to HyNet™ literature for more information.	RS-485. Involves additional hardware and/or external software.
18	NE 0 (OFF) NETWORK SETUP	0 = (OFF) No network 1 = Network address (on)	Menu item appears when SA is a non-zero number. If a system address exists a setting of 1 opens the network configuration menu. 0 = no network communication 1 = allows configuration of network addresses. In designating a network address, when the primary operator is set to 1, all subsequent operators (maximum of 3 subsequent operators when using HyNet) must be set to sequential numbers. For example, Primary gate operator is set to 1, the next 3 gate operators in series must have networked addresses set to 2, 3, and 4. Each grouping of 1 to 4 operators that are using HyNet, must be labeled as such. If using WIN-PC to network gate operators, contact Engineering.	RS-485. Involves HyNet™ and latest software.
19	OI 0 ENABLED OPEN INPUT OI 1 SLD ENABLED OPEN INPUT 3 OI 2 LOOP ENABLD OPEN INPUT 3	When OPEN INPUT 3 is wired and activated by an external access control device, choose 1 of 3 settings	HydraSupply XL ONLY. Controls the function of Terminal 6, OPEN INPUT 3 If using Terminal 12 connection functionality, read AM menu item below. OI setting descriptions: 0 = Lower Barrier (Open Roadway) 1 = Lower Barrier only if Arming Loop Vehicle Detector (Terminal 12) or equivalent HY-5A/HY5B detector is also triggered when open input 3 is activated. 2 = Lower Barrier if Outside Obstruction Loop Vehicle Detector (Terminal 11), Arming Loop Vehicle Detector (Terminal 12), or equivalent HY-5A/HY5B detectors are also triggered when open input 3 is activated	OPEN INPUT 3 COM and Vehicle Detectors * (depending on which menu settings are selected)
20	AM 0 ARMING ONLY ARMING LOOP AM 1 ALD & OOLD ARMING LOOP	0 = Wired connection to terminal 12 is for arming loop only. 1 = Adapts the arming loop to work as an additional outside obstruction loop. AM 1 ALD & OOLD	HydraSupply XL ONLY. Terminal 12 is convertible and can be used as an arming loop or an arming loop and an additional outside obstruction loop.	ARMING LOOP VEHICLE DETECTOR (Terminal 12) COM Vehicle detector (or HY-5A)
21	ELDO RUN MODE EXIT LOOP SET	0 = Run mode 1 = Show frequency 2 = Show call level 0-7 3 = Set Frequency	Controls the HY-5A Free Exit loop detector.	HY-5A

Table 10: INSTALLER Menu HydraSupply XL

	Installer Menu	Setting Options	Menu Tasks & Explanations	STC Wire Connections
22	ILDO RUN MODE IND OBS LOOP SET	0 = Run mode 1 = Show frequency 2 = Show call level 0-7 3 = Set Frequency	Controls the HY-5A Inside Obstruction Loop detector.	HY-5A
23	OLDO RUN MODE OUT OBS LOOP SET	0 = Run mode 1 = Show frequency 2 = Show call level 0-7 3 = Set Frequency	Controls the HY-5A Outside Obstruction Loop detector.	HY-5A
24	SLDO RUN MODE SHADOW LOOP SET (Reset Loop Set)	0 = Run mode 1 = Show frequency 2 = Show call level 0-7 3 = Set Frequency	Controls the HY-5A Shadow Loop detector.	HY-5A

SETTING THE CLOSE TIMER

The Close Timer assigns how many seconds will pass before the gate operator initiates closure of a fully opened gate after all open commands and reversing sensor inputs have ceased and loops cleared. It is recommended that every gate operator have the close timer set to a specific number of seconds (for example, 5 seconds) unless a hard-wired closing device is connected to the gate operator, such as a “hold to close” push button station.

To adjust the time (1 to 99 seconds) it takes before the operator initiates gate closure, take the following steps:

1. At a gate status display, press the Menu button twice. This accesses the User Menu and the Close Timer display appears.
- NOTE:** If you want gate personnel to operate the gate with the Hold to Close feature found in some push button stations, then set the Hold to Close menu item to 1. When the Hold to Close menu item is active (set to 1), the Close Timer menu item is unavailable.
2. Use the Select, and then Next or Previous buttons to navigate and change the number of seconds appearing on the display. Refer to “Menu Mode Navigation” on page 32.
 3. To exit the User Menu, press the Menu button. The gate status appears in the display indicating you have returned to Run Mode.

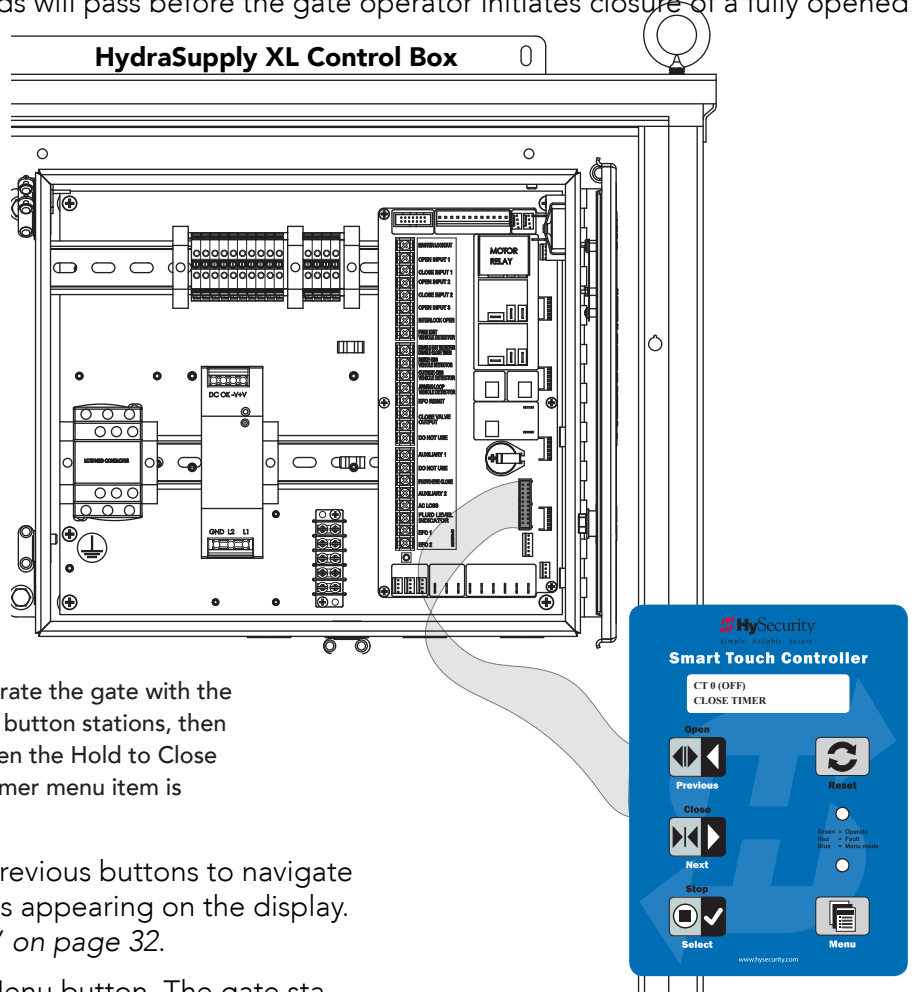

Smart Touch Display and Keypad on Control Box Lid

TEST THE OPERATOR

Complete the installation by testing the operation of the gate.

NOTE: The operator must be turned on and in Run mode. A Run mode display appears on the STC. If a Run mode status does not appear on the display, press Reset. If an error, alert, or fault appears on the display, refer to the *Troubleshooting* section to learn how to clear the display and return to Run mode.

1. Press Open to open the gate.
2. Test the operator.
 - ♦ Cycle the gate a few times by pressing the Close and Open buttons.



Always make sure area is clear of personnel and debris before using the Emergency Fast Operate (EFO) function.

- ♦ If installed for emergency fast operation, test the EMERGENCY CLOSE using the constant hold device.
- ♦ Observe the travel speed of the gate when you press and hold the Emergency Close button. The wedge's blocking plate will close within 1 to 2 seconds and ignore any photo eye, vehicle loop, or other safety sensor inputs.

STC Inputs & Wiring

This section provides information about the Smart Touch Controller, its inputs for peripheral connections, and its monitoring capabilities. This section explains how to:

- Make Connections on the Smart Touch Controller
- Integrate with Security Systems
- Connect HY-5A Vehicle Detectors
- Connect Accessory Devices
 - ◆ Entrapment Sensor Connections
 - ◆ Access Controls
 - ◆ Push-button station
 - ◆ User Relays

Terminal 1	MASTER LOCKOUT
Terminal 2	OPEN INPUT 1
Terminal 3	CLOSE INPUT 1
Terminal 4	OPEN INPUT 2
Terminal 5	CLOSE INPUT 2
Terminal 6	OPEN INPUT 3
Terminal 7	INTERLOCK OPEN
Terminal 8	FREE EXIT VEHICLE DETECTOR
Terminal 9	DISABLE EXIT DETECTOR DISABLE CLOSE TIMER
Terminal 10	INSIDE OBS VEHICLE DETECTOR
Terminal 11	OUTSIDE OBS VEHICLE DETECTOR
Terminal 12	ARMING LOOP VEHICLE DETECTOR
Terminal 13	EFO RESET
Terminal 14	CLOSE VALVE OUTPUT
Terminal 15	
Terminal 16	DO NOT USE
Terminal 17	AUXILIARY 1
Terminal 18	DO NOT USE
Terminal 19	PHOTO EYE CLOSE
Terminal 20	AUXILIARY 2
Terminal 21	AC LOSS
Terminal 22	FLUID LEVEL INDICATOR
Terminal 23	EFO 1
Terminal 24	EFO 2

Inputs Label for HydraSupply XL

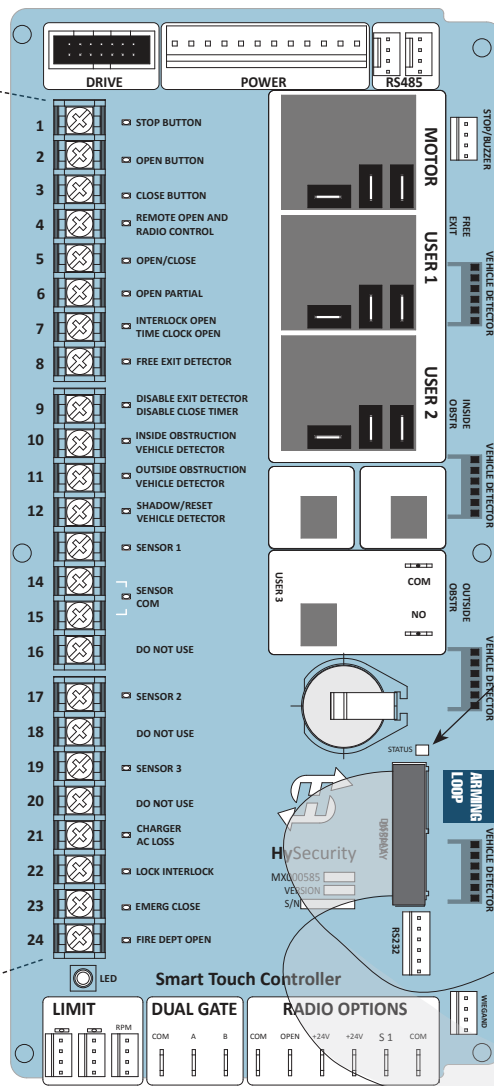

Heart beat power indicator

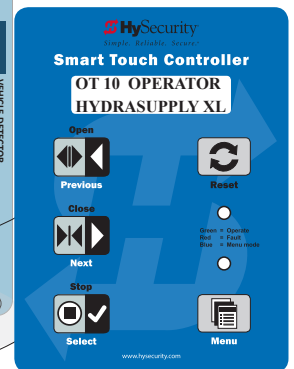

Display & Keypad

OVERVIEW OF THE SMART TOUCH CONTROLLER

The Smart Touch Controller uses LED's to indicate active inputs when AC power is present. For operators that use only DC power, you can press a Tact push button to show the active inputs. This Tact push button is at the bottom left corner near the #24 terminal input.

On a new operator no active inputs should appear until external accessories and wiring are attached. If any inputs are active before connecting external wiring, refer to "Troubleshooting".

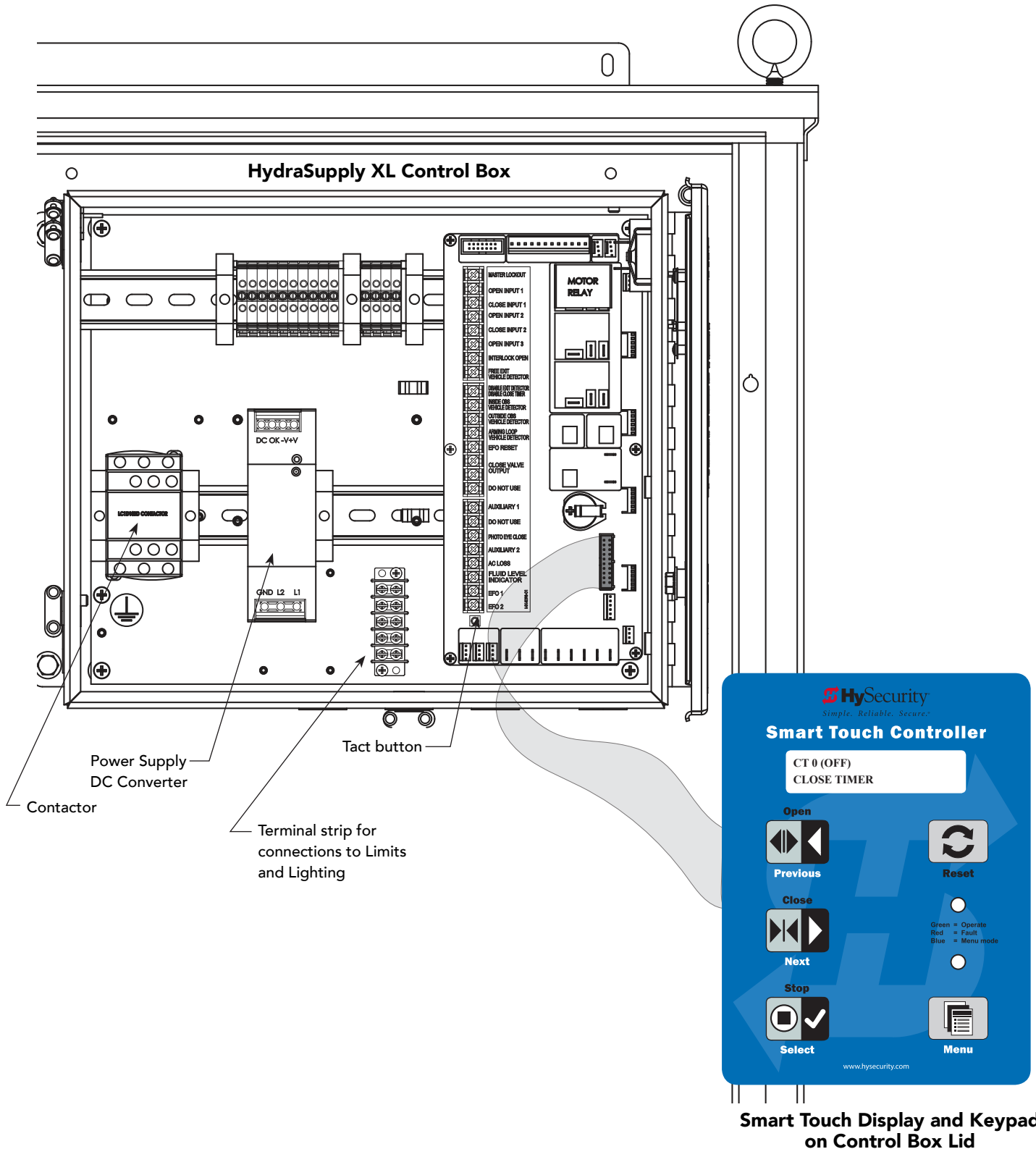

INTEGRATING WITH SECURITY SYSTEMS

The HydraSupply XL provides a 2-wire, serial interface (RS-485 connection) which allows remote access to one or more operators. With software protocols provided by HySecurity, bi-directional status updates and control commands are easily integrated with a central controller (computer or server), which becomes the master to the connected operators. Up to 31 physical operators can be polled from the central master command station. Reset requests, gate control, gate status, and gate faults can be monitored and information can be retrieved from the central command station.

NOTE: The RS-485 interface is also used to communicate with the HyNet Gateway, a web-enabled interface.

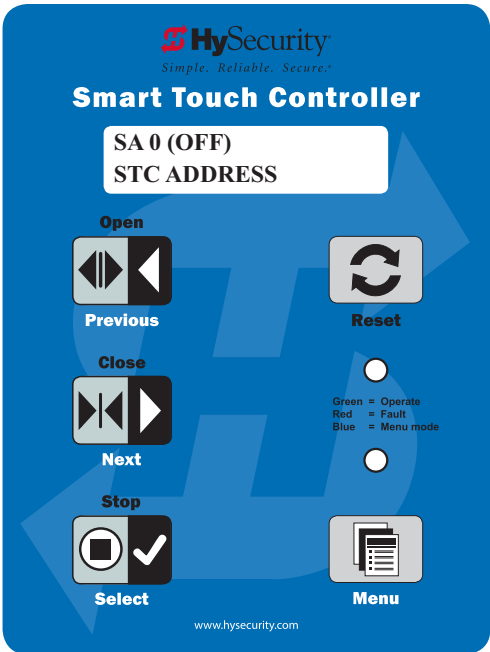
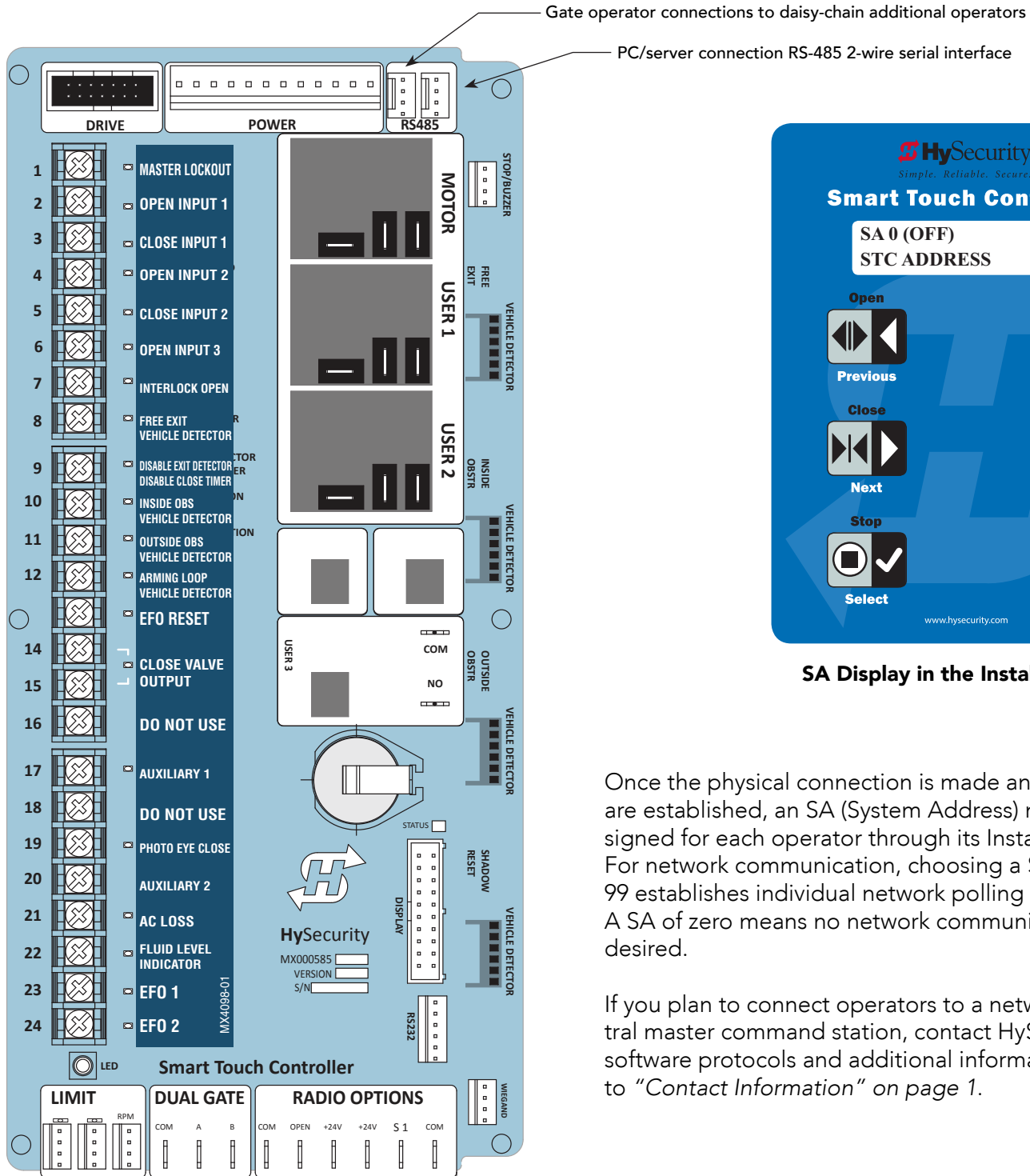

SA Display in the Installer Menu

Once the physical connection is made and protocols are established, an SA (System Address) must be assigned for each operator through its Installer Menu. For network communication, choosing a SA of 1 to 99 establishes individual network polling addresses. A SA of zero means no network communication is desired.

If you plan to connect operators to a networked central master command station, contact HySecurity for software protocols and additional information. Refer to "Contact Information" on page 1.

SMART TOUCH CONTROLLER INPUTS

This section provides information about the Smart Touch Controller (STC), its inputs for peripheral connections used in the HydraSupply XL. When you select an input, be sure to review User & Installer Menu Items tables for associated programming options. The programming options affect how the gate operator functions.



All open, close and EFO inputs assume external, line of sight, push button or similar, external control consoles. Monitored, supervisory network stations can also be connected to the Smart Touch Controller via HyNet and RS-485 communication protocols.

1. All the Smart Touch Controller inputs listed below are shown as a single input. The second wire is connected to the Common Terminal Bus.
2. The Emergency Close input's are an exception and requires a +24V input. Review "EFO Connections: Wiring Diagram" on page 17. For additional safety purposes, an emergency close reset connection is also a requirement.



STC TERMINAL INPUTS

NOTE: A label for HydraSupply XL overlays the existing Smart Touch Controller inputs. The following table explains the HydraSupply XL inputs. The default for HydraSupply XL is customized at Build Year 1, (BY 1). Build Year 1 is a configuration that is NOT compliant with UL 325 - 2016 Standard of Safety. HydraSupply XL meets UL 508A standards.

OPEN = Roadway Open (blocking plate lowers to grade).
CLOSE = Roadway Closed (blocking plate raises to barrier height).

No.	Smart Touch Terminal	HydraSupply XL Terminal Function & Description	Associated Menu Items
1	Master Lockout	Lockout intended for a remote control connection from the master control console or panel. Used to disable operation of secondary/remote control console. If the Master Lockout input is not connected to common, Open Inputs 2 and 3 and Close Input 2 will be disabled. (Terminals 4, 5, and 6 respectively).	
2	Open Input 1	Open input intended for connection from a master control console or panel. Opens the wedge blocking plate from a master control console or other access control device.	HC, HO
3	Close Input 1	Close input intended for a connection from a master control console or panel. Closes the wedge blocking plate from a master control console or other access control device.	HC, HO
4	Open Input 2	Open input intended for a connection from a remote control console or panel. Opens the wedge blocking plate from a remote control panel or other access control device. Open Input 2 is disabled when the Master Lockout input is not connected to common.	
5	Close Input 2	Close input intended for a connection from a remote control console or panel. Closes the wedge blocking plate from a remote control panel or other access control device. Close Input 2 is disabled when the Master Lockout input is not connected to common	
6	Open Input 3	Use Open Input 3 for keypad, card reader, or other open device connection. The OI (Open Input) item in the Installer Menu provides options on how this input functions. If Master Lockout input is not connected to common, Open Input 3 is disabled. Installer Menu Setting: OI <n>, Open Input 0 = Input Enabled Setting 1 or 2 = An arming loop input must be active before this input will open the barrier.	OI
7	Interlock Open	Commonly used in a sally port system. The barrier will not leave the close limit as long as the input is active.	
8	Free Exit Vehicle Detector	Connection for exit vehicle loop detector. Open (lower) the wedge blocking plate or reverse its closing, using this input connection. If using HY-5A vehicle loop detectors, insert HY-5A into FREE EXIT socket.	

Table 11: Smart Touch Controller Inputs

No.	Smart Touch Terminal	HydraSupply XL Terminal Function & Description	Associated Menu Items
9	Disable Exit Detector Disable Close Timer	Input has two functions. Access DT (Installer Menu) to change the functionality of this input. When active, the input defaults to disable the Free Exit vehicle loop detector. The free exit vehicle loop detector acts similar to an obstruction detector and will not open a fully closed gate, but will cause a closing gate to reverse. Changing the setting to 1 through the DT Installer Menu item disables the internal close timer. If using HY-5A vehicle loop detectors, insert HY-5A into FREE EXIT socket.	DT
10	Inside Obstruction Vehicle Detector	Connection for vehicle loop detector. This input will usually prevent the wedge from starting close. Installer menu item IR setting will determine how the wedge will function if this input goes active while closing. Available options are stop, stop and reverse, or continue closing. If DL is set to 3 in the installer menu, the wedge will close if the inside and outside obstruction loop inputs are activated at the same time, then released. If using HY-5A vehicle loop detectors, insert HY-5A into insert HY-5A into INSIDE OBSTR socket.	IR, DL
11	Outside Obstruction Vehicle Detector	Connection for vehicle loop detector. This input will usually prevent the wedge from starting close. Installer menu item OR setting will determine how the wedge will function if this input goes active while closing. Available options are stop, stop and reverse, or continue closing. If DL is set to 3 in the installer menu, the wedge will close if the inside and outside obstruction loop inputs are activated at the same time, then released. When OI is set to 2 in the installer menu, then Open Input 3 will only function if the Outside obstruction loop or Arming loop input is active If using HY-5A vehicle loop detectors, insert HY-5A into OUTSIDE OBSTR socket.	OR, DL, OI and AM
12	Arming Loop Vehicle Detector	Connection for vehicle loop detector. This input will normally have no function but may be used as an arming loop. Installer menu item setting AM = 1 will allow this input to also be used as an outside obstruction detector. When OI is set to 1 or 2 in the installer menu, then Open input 3 will only function if the arming loop is active. If using HY-5A vehicle loop detectors, insert HY-5A into SHADOW LOOP socket.	AM and OI
13	EFO Reset	To reset the gate operator after an EFO event, a hardwire reset (Input 13) is required. Best practice is to connect Input 13 to a non-latching switch. The switch resets the Smart Touch Controller after an EFO input has been used and the operator is in Entrapment Mode. The Entrapment Mode will be cleared when this input is activated then released. If a button is not provided on a control panel, then this input can be tied/jumpered to an open input.	
14	Close Valve Output	 <p>Connection to the Close Valve. Turns ON and OFF the close valve when a close input is activated. Do not wire anything to this input in the field. Will not be activated when EFO is triggered.</p>	
15			
16	DO NOT USE	Non- functioning input. No field connections should be made to this input terminal	
17	Auxiliary 1	Non-functioning input, but available for future software development.	
18	DO NOT USE	Non-functioning input. No field connections should be made to this input terminal.	
19	Photo Eye Close	Normally Open input. When connected to a photo eye and activated, the signal prevents the barrier from closing.	PE
20	Auxiliary 2	Non-functioning input, but available for future software development.	
21	AC Loss	The installer must connect this input to the DC signal output indicating the presence of AC power in the battery cabinet. When this input is not active, the HydraSupply XL functions depending on AP settings. The setting configures how the gate functions when AC power fails.	AP, AD
22	Fluid Level Indicator	 <p>DO NOT connect to this input! Factory use ONLY! Active input connects to the fluid level sensor in the reservoir. When this input becomes inactive, the display will declare FAULT 8 – LOW FLUID LEVEL and the barrier will not operate. Check connections and fluid levels. See “Troubleshooting” on page 53.</p>	
23	EFO 1	Connect to 24V via the EFO button on the master control console or panel. The connection allows the history log to show date & time activation and enters Entrapment Mode when the close limit is reached. Exiting from Entrapment Mode, requires that the input remain de-energized and the EFO Reset console connection (Terminal 13) is triggered (activated) and released. See “Installing a Push Button Emergency Fast Operate (EFO) Switch” on page 17.	OC is hidden, defaults to 1 (enabled/active)
24	EFO 2	Connect to 24V via the EFO button on the remote control console or panel. The connection allows the history log to show date & time activation and enters Entrapment Mode when the close limit is reached. Exiting from Entrapment mode, requires that the input remain de-energized and the EFO Reset console connection (Terminal 13) is triggered (activated) and released. See “Installing an Emergency Fast Operate (EFO) Reset Switch Push Button Device” on page 18.	Required programming: OC is hidden, defaults to 1 (enabled/active) Review optional items:

USER RELAYS - PROGRAMMING PROCEDURE

The Smart Touch Controller is able to interface with many types of external devices through the use of three user programmable output relays: two mechanical relays (User 1 and User 2), and one solid state relay (User 3) which is used most often for connection to flashing devices.

All of the user relay functions identified and described in the table below are accessible in the Installer Menu selections.

NOTE: A setting of zero disables a User Relay. The User Relays will operate normally to 18VDC. Below 18VDC, alert notification occurs. On StrongArm CRASH products User 3 relay is unavailable. It is pre-wired for the LED lights.

Use the STC buttons to program the user relays according to the following steps:

1. Select the relay you wish to use through the "Table 10: INSTALLER Menu HydraSupply XL" on page 38. For example: RL 1 (RELAY 1 LOGIC) or RL 2 (RELAY 1 LOGIC).
2. Select the appropriate function (1 through 32) by changing the display to the associated number listed in the table. Use the Select, Next and Previous buttons to make your selection. See "Menu Mode Navigation" on page 32.

Relay No.	Name	Description	Wire Connection
1	Close limit output CLOSE LIM	Output can be used as an interlock signal to another operator's interlock input, or simply to indicate that the barrier is secure. The relay is "off" when the barrier is closed. The relay energizes when the fully-closed limit is released. (Any open command energizes the relay.)	Relay 1 or 2 or 3
2	Close limit pulse output CLOSE PULS	Used in a sequenced system to command a second machine to close. Generates a brief pulsed output that occurs when the close limit is triggered.	Relay 1 or 2 or 3
3	Open limit output OPEN LIMIT	Indicates a full-open position. This output becomes active when an open-limit is triggered and deactivates when the open-limit is released or a close command is received. Note that this input may be used for traffic light connection.	Relay 1 or 2 or 3
4	Open limit pulse output OPEN PULSE	Used in a sequenced system to command a second machine to open. Generates a brief pulsed output that occurs when the open limit is triggered.	Relay 1 or 2 or 3
5	Warn before/during operate output WARN B4 OP	Controls an external warning device. This output operates at the same time as the internal warn before operate buzzer.	Relay 1 or 2 or 3
6	Barrier Lock output GATE LOCK	Controls external solenoid or magnetic locks. In both directions of travel, this output is activated about 7/10ths of a second before the operator starts moving the barrier and remains active while moving. Output remains active, for a few seconds, after stopping.	Relay 1 or 2 or 3
7	Barrier forced open output FORCE OPEN	Activated if the barrier is forced off the closed limit switch and the operator is not able to restore the barrier to full closed position within four seconds. NOTE: This alarm resets itself in 30 seconds.	Relay 1 or 2 or 3
8	Arm open too long output OPEN 2 LONG	Activates when the barrier is open longer than the user-selected period of time. Adjustable from 0 seconds with 15 to 135s selectable delay time frames in 30s increments. NOTE: TL - Open TIME ALERT adjustments can be made in the Installer Menu.	Relay 1 or 2 or 3
9	Safety Mode Alert output SAFE MODE	Activated when the system is in Safety Mode or Entrapment Mode. Entrapment Mode means the barrier is stopped. EFO inputs were activated.	Relay 1 or 2 or 3

Table 12: Programmable User Relays

Relay No.	Name	Description	Wire Connection
10	Entrapment Mode Alert output ENTRAPMENT	Activated only when in the Entrapment Mode.	Relay 1 or 2 or 3
11	Unauthorized Vehicle Entry output TAILGATER	Relay activates when a vehicle enters from the outside without a valid input from an access control device. As an example, the relay may be used to connect a camera or signal light. When the user relay is assigned #11 and the relay is activated, the camera or signal light turns on. The devices turn off when an access control input receives an open signal or the barrier/gate reaches the close limit	Relay 1 or 2 or 3
12	Outside Obstruction Vehicle Detector output OUTS LOOP	This output is active whenever the Outside Obstruction Loop Detector is tripped. May be used as an arming loop output.	Relay 1 or 2 or 3
13	Loitering Alert LOITERING	Indicates a vehicle is loitering on the Outside Obstruction Loop with the barrier closed. Adjustable from 0 seconds with 15 to 135s selectable delay time frames in 30s increments. NOTE: LT - LOITERING ALERT adjustments can be made in the Installer Menu. The LT Installer Menu display only appears when using this relay.	Relay 1 or 2 or 3
14	Arm nearing full travel output NEAR LIM	Activated when the barrier is 3s from expected limit switch. NOTE: If the operator has not yet learned limits, it will energize Relay 14 when the motor begins moving the barrier.	Relay 1 or 2 or 3
15	Arm failure output FAULT ALT	Activated to report occurrence of a problem. Indicates the system is in an Error Mode, Fault Mode or Entrapment Mode.	Relay 1 or 2 or 3
16	Motor Running output MOTOR RUN	Active when the motor is running and barrier is in motion.	Relay 1 or 2 or 3
17	AC Power Failure output AC FAIL	This relay is normally energized and drops with loss of AC power.	Relay 1 or 2 or 3
18	DC Power Failure output LOW BATT	DC operators only. The relay activates when the battery power is very low, but the output ceases when the battery is dead. The relay is triggered when the battery is less than 20 volts.	Relay 1 or 2 or 3
19	Flasher Relay FLASHER	Flashes lights once per second. The relay is constantly pulsing except when the open limit switch is triggered. * Preferred connection is Relay 3, a solid state relay (except on Crash operators). On StrongArm M30/M50, Relay 3 is hard-wired for the LED barrier arm lights.	Relay 1 or 2* (Relay 3)
20	Free Exit Loop Vehicle Detector output EXIT LOOP	Active when the Free Exit Loop is tripped.	Relay 1 or 2 or 3
21	Inside Obstruction Vehicle Detector output INS LOOP	Active when the Inside Obstruction loops is tripped.	Relay 1 or 2 or 3

Table 12: Programmable User Relays

Relay No.	Name	Description	Wire Connection
22	Reset Loop Detector output CENT LOOP	Active when the Reset loop detector is tripped.	Relay 1 or 2 or 3
23	NOT AVAILABLE	Not available on the HydraSupply XL. Terminal 22 Lock Interlock has been re-labeled to Fluid Level Indicator. Wired at the factory.	Relay 1 or 2 or 3
24	NOT USED	Not used on the HydraSupply XL. Used on slide gates. Active when the partial open position is reached or exceeded.	Relay 1 or 2 or 3
25	DC Power Alert BATT OK	Deactivates when the software detects a low battery voltage (below 21VDC, but greater than 18VDC) for a duration of 2 seconds or more. To slow battery drain, accessory power loads are shed.	Relay 1 or 2 or 3
26	Free Vehicle Detector Pulse EXIT PULS	Activates when the Exit Loop Detector is tripped and causes a 250mS pulse output to occur	Relay 1 or 2 or 3
27	Not Open (requires AC power) NOT OP AC	When AC power is detected, this relay activates when the gate is NOT on the open limit. If AC power fails, or the gate is on the open limit, the relay is deactivated.	Relay 1 or 2 or 3
28	Flasher ((requires AC power) FLASH AC	Controls flashing lights that pulse 500ms per second. The relay is constantly activating except when the open limit switch is triggered or AC power fails.	Relay 1 or 2 or 3
29	Set aside for Factory Use Only TEST OPEN	Used for testing only. DO NOT use in field connections unless directed by Tech Support.	
30	Arm Break	Used with barrier ARM gates only. When break away arm function triggers, stops travel.	Relay 1 or 2 or 3
31	Warn Operate Run WARN THRU (Relay Logic 1)	Relay is active while warn before and motor running.	Relay 1 or 2 or 3
32	Partial Open Pulse POL PULS (Relay Logic 1)	Relay pulses when partial open activated and when partial open limit reached. Often used at a sequenced gate site.	Relay 1 or 2

EXTENDED RELAY MODULE OPTION

The extended relay module provides 8 numbered NO (normally open) mechanical relays. R4, RELAY 4 LOGIC through R11, RELAY 11 LOGIC can be accessed through the Installer Menu. Set the number for the relay. See "Table 12: Programmable User Relays" on page 48.

Wire communication cable connections between the DUAL GATE ports, at the base of the STC, and the extended-mechanical relay module. Black and red wires connect to RS-485 communications port at the top of the Smart Touch Controller.

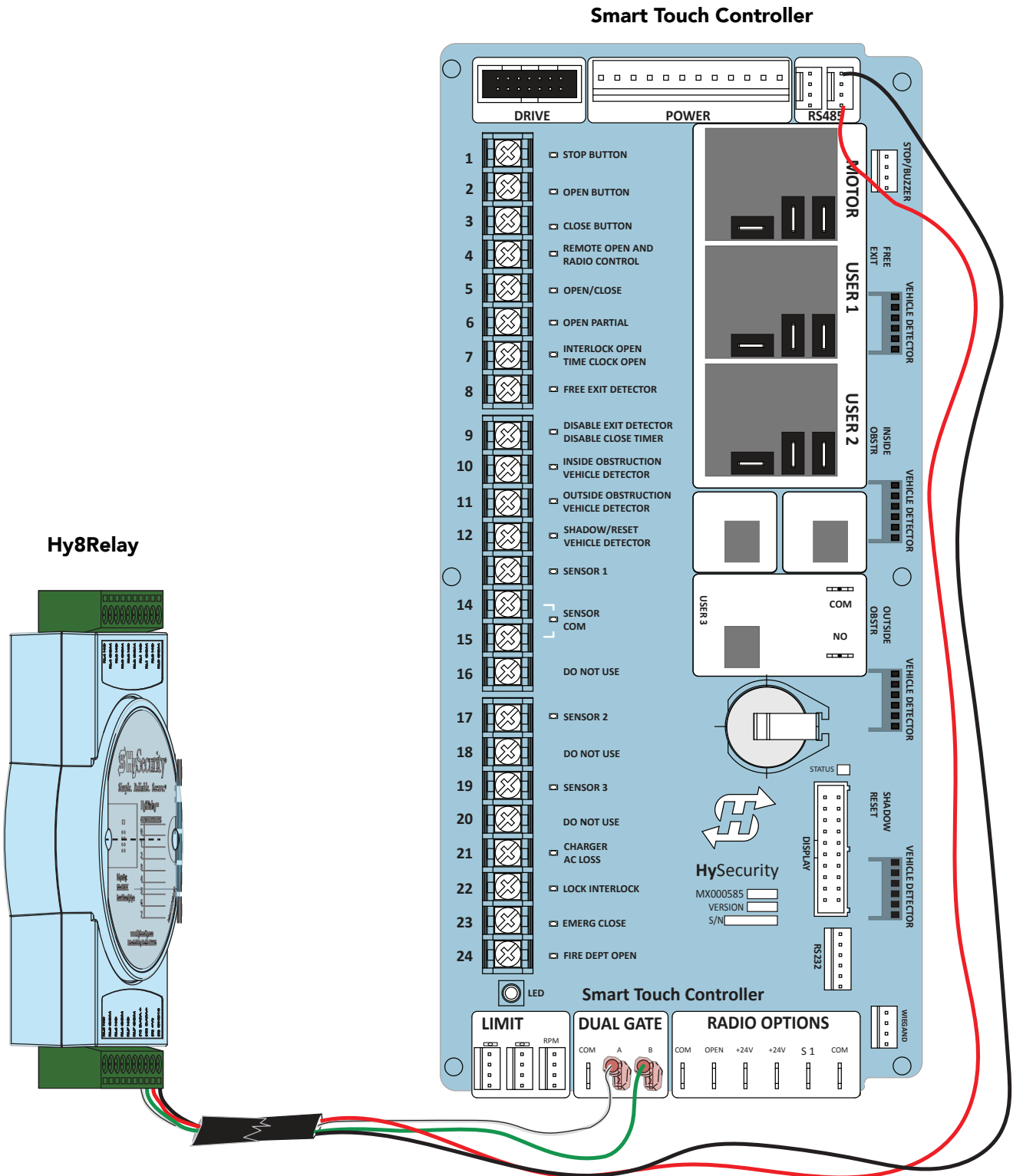

Page intentionally left blank

Troubleshooting

The Smart Touch Controller reports system abnormalities using three simultaneously occurring methods:

- Codes presented on its display (alert, fault or error)
- Activation of a buzzer which emits a series of chirps at defined intervals
- Stop gate travel (and/or reverse direction of travel)

Refer to “Table 13: Troubleshooting Codes, Causes and Corrective Action” on page 54 for details concerning identification and description of Alerts, Faults and Errors.

To help in diagnosing a controller board problem, the active status of each input on the Smart Touch Controller is indicated by its associated LED.

- On AC-powered gate Operators: Active-input LEDs are always illuminated.
- On DC-powered gate Operators (with AC input OFF or disconnected): Press and hold the Tact button to illuminate the active-input LEDs.

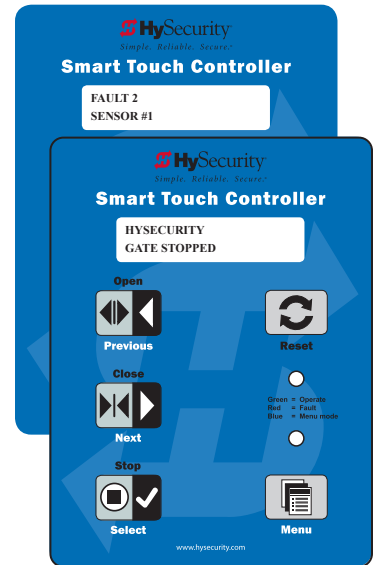

NOTE: A qualified technician may troubleshoot the operator with the aid of the information and procedures that follow. If it is necessary to call a distributor for assistance, be sure to have the model and serial numbers available. Other helpful information is the job name, approximate installation date, and service records of any recently-performed maintenance work.

SYSTEM DIAGNOSTIC MESSAGES

Code	Priority	How to clear
ALERT	Low	Enter new command such as Open or Close.
FAULT	Medium	Press the Stop or Reset button
ERROR	High Serious issue that may require technical service.	Errors can only be cleared by pushing the Reset button or cycling power.

NOTE: The green LED near the coin-sized battery on the Smart Touch Controller is the “heartbeat” of the processor. This LED flashes continuously and at a constant rate when the system is operating normally. When a fault, error, or alert occurs, it turns red.

The Smart Touch Controller maintains self-diagnostics. Specific codes appear on the display and the Audio Alert buzzer emits distinctive chirping sounds. Any Alert, Fault, or Error is logged into memory and stamped with the date and time. These diagnostic messages can be retrieved for analysis purposes via the Event Log (see Access the Event Log through the User Menu) or optional use of S.T.A.R.T. software and a PC laptop.

NOTE: S.T.A.R.T. configuration and diagnostic software is available at no charge from www.hysecurity.com.

Table 13: Troubleshooting Codes

Table 13: Troubleshooting Codes, Causes and Corrective Action			
Type	Alert/Fault/Error Display	Buzzer Chirp Sequence	Possible Cause & Suggested Corrective Action
ALERT	HYSECURITY ENTRAPMENT MODE <i>Entr</i>	2 chirps per second every 2s while control input is active	An emergency close with constant hold has caused the entrapment code to appear. When a command of this nature is received, the operator stops and moves into ENTRAPMENT mode. Clear the code and return to run mode operation by pressing the Reset button.
ALERT	HYSECURITY SAFE MODE <i>SAFE</i>	2 chirps once when in Safe Mode	The operator has exited entrapment mode. Refer to the description above. NOTE: Gate will operate, if it receives a RUN command.
ALERT	LOW 24VDC DC BUSS < 21V	No chirps; LCD flashes for 1s every 5s	Only occurs in DC powered operators.
ALERT	DEAD BATTERY DC BUSS < 21V	3 chirps upon any operating command entry	DC operators only. Appears when the 24 VDC power drops too low, disabling the operator which helps prevent damage to the batteries from excessive discharge. Verify the AC power is present at the charger, the charger is on and charging (Red LED is illuminated). The charger should shut off (Green LED) when the batteries charge to 29.0 VDC. If the batteries cannot “hold a charge” replace them.
ALERT	NO AC POWER	Chirps once whenever the gate reaches the close limit	AC power is shut off at the source (breaker) or is not connected. The operator’s AC power switch is turned off or the main circuit breaker has tripped. Have a licensed electrician check the wiring. Connect AC power to the operator. Reset circuit breaker at the electrical panel. Reset the operator circuit breaker. Turn AC power switch on.
ALERT	!ACTION BLOCKED GATE EDGE (Open or Close) <i>GED</i>	5 chirps indicating that the command cannot be initiated	Operator received command to run open, but movement is prevented. Gate edge blocked or disconnected and causes operator to enter SAFE mode.
ALERT	ALERT 1 FORCED OPEN	2 pulses per second for 30s	Set FA 1 in the User Menu, to enable this option. The operator will attempt to re-close itself if forced off the close limit switch, the buzzer sounds for 30 seconds. Check for attempted unauthorized access, external pressure trying to open the gate or a mis-adjusted/failed closed limit switch.
ALERT	ALERT 2 DRIFT CLOSED	2 pulses per second for 10 seconds	Set F0 1 in the User Menu, to enable this option. If a gate should begin to drift closed it automatically reopens (for up to 4s) once it leaves the full open limit. If it is not back on the open limit at the end of 4s, an audible alert occurs. Check for mis-adjusted/failed open limit, mis-adjusted brake valve, outside pressure (wind, fallen trees) or cylinder leakage affecting drift issue.
ALERT	ALERT 3 EXCESS DRIFT	Gate drift in transit - Advisory only. The alert appears and is being prevented from re-opening.	Will self-clear after an open or close input.
ALERT	ALERT 4 THERMAL OVERLOAD	2 chirps per second every 15 seconds	The motor windings have exceeded a preset temperature generally due to excessive current. Verify: The motor connections are correct for the supply voltage Running voltage is within 10% of rated High starting currents last 2 seconds or less; if not and voltage during start is correct, on 1Ø units you can replace the start switch/capacitor Motor running current (all phases) is at or below rated (at normal pressures) When the motor is cool, open the motor connection box, disconnect the 2 small wires going into the motor, and use an ohmmeter to check continuity of these wires. They should be a short circuit; if not, replace the motor.
ALERT	ALERT 5 BOTH LIM ACTIVE	2 chirps per second every 15 seconds	The STC is seeing both limits tripped at the same time. For HydraWedge SM50, check for a stuck limit switch or debris caught in limit switch area and repair any wiring issues. On electromechanical gate operators and StrongArmCrash, reset the limits through the Installer Menu item, LL Learn Limits.

Table 13: Troubleshooting Codes, Causes and Corrective Action

Type	Alert/Fault/Error Display	Buzzer Chirp Sequence	Possible Cause & Suggested Corrective Action
ALERT	ALERT 6 LIM NOT RELEASED	2 chirps per second every 15 seconds	Is the pump developing pressure? Are the brake valves set properly? Is there hardware holding the gate? Check fluid levels and brake valve settings.
ALERT	ALERT 7 FREQ SHIFT FAULT	2 chirps per second every 15 seconds	HY-5A detector has detected a frequency change outside the normal range. Check the loops and the integrity of the loop installation.
ALERT	ALERT 8 LOOP SHORTED	2 chirps per second every 15 seconds	HY-5A detector has detected a short circuit in the loop. Temporarily switch detector to be sure the loop is at fault and then repair it.
ALERT	ALERT 9 LOOP OPEN	2 chirps per second every 15 seconds	HY-5A detector has sensed that the loop has become an open circuit. Check all connections and/or use an ohmmeter to find out where the break is.
ALERT	ALERT 10 I2C BUS ERROR	2 chirps per second every 15 seconds	Communication issue between the HY-5A and the Smart Touch Controller; reset and try again. Replace the HY-5A if the problem continues.
ALERT	ALERT 11 DETECTOR FAULT	2 chirps per second every 15 seconds	Unknown fault; perform the megaohm test and fix the loop if necessary. Replace the HY-5A if the problem continues.
ALERT	ALERT 12 ON TOO LONG	2 chirps per second every 15 seconds	The detector believes there has been a vehicle on the loop for more than 5 minutes. Is there something metal on (or near) the loop? Is the sensitivity adjustment set too high? Is the roadway solid? If the underground loop moves it will give false readings. There may be a problem with the loop itself. Check with a megohm meter. New loops should read 100 mega-ohms or better, between 50 and 100 operation are generally OK, below 50 mega-ohms install a new loop.
ALERT	ALERT 17 BAD COIN BATTERY	2 chirps per second every 15 seconds	Turn off AC power and replace the 3V coin battery that controls the internal clock. Use a CR2032 coin battery.
ALERT	ALERT 19 FALSE SLOWDOWN	2 chirps per second every 15 seconds	Appears only on gate operators with VFD. Slowdown switch tripped and released (less than 1 second) in middle of run. Check for loose wires, limits and misaligned rails or limit ramps.
ALERT	ALERT 20 EXT LOCK FAILED	2 chirps per second every 15 seconds	An interlock contact is closed, indicating that the gate latch (lock) is engaged, preventing the operator from starting. Check the interlock terminal and wiring.
ALERT	ALERT 22 INTLOCK FAILURE	2 chirps per second every 3 seconds	Appears when the RS-485 communication connection is lost for more than 5s between interlocked (dual gate) or sequenced gate operators. Check cable connections and wiring. Make sure both operators are working properly and have compatible software versions. The alert auto clears when communication between the two operators is restored. If the operator on site is a singular gate and the display code ALERT 22 appears, access the Installer Menu. Verify the Installer Menu items: DG (Dual gate) and SG (Sequential gate) are both set to zero.
ALERT	ALERT 24 EXT RELAY FAULT	2 chirps per second every 15 seconds	The Hy8Relay (extended relay module) is not being recognized. Alert noted in diagnostic log. Check the wiring: Make sure the slide switch on the side of the extended relay module is set at "Normal." (Y) Data + is connected to "A" DUAL GATE. (G) DATA - is connected to "B" DUAL GATE. Connector cable (4-pin) attaches to RS-485. If the Hy8Relay module is not connected, access the Installer Menu and check that the extended user relays are set to zero. STC = R4 to RB (7-segment display) SDC = R3 to R9 (16 character display) STC = R4 to R11 (16 character display)

Table 13: Troubleshooting Codes, Causes and Corrective Action

Type	Alert/Fault/Error Display	Buzzer Chirp Sequence	Possible Cause & Suggested Corrective Action
ALERT	ALERT 25	N/A	HyNet Only. The HyNet coin battery is dying. Turn off AC power to the HyNet and replace the existing coin battery with a CR1220 coin battery. Turn On power to the HyNet. The ALERT should reset and disappear from the display.
ALERT	ALERT 26	2 chirps per second every 15 seconds	Only appears in HydraSupply XL. When valve closures or IES trips do not detect limit switch triggers or, if the appropriate limit switch is not reached within 10s of receiving an operate command and the pressure switch is open, then Alert 26 – Lim Not Reached will be declared. If the barrier moves by pressing an operate command, the display resets and the ALERT 26 timer rearms.
ALERT	ALERT 27	2 chirps per second every 15 seconds	Only appears in HydraSupply XL. The fluid level in the accumulator is low. An EFO may not trigger properly. Have service personnel check the HydraSupply XL. Cycle the barrier and watch the pressure gauge. If the pressure is low, the blocking plate does not rise or the motor times out, check hoses for leaks. If necessary, recharge the accumulator. While ALERT 27 appears on the display, a renewed close command will attempt to run the barrier, but the alert will not clear unless the close limit is reached or a reset is pressed.
ELD OOLD IOLD SLD RLD	“Vehicle Loop Detectors”		Appears in sequence with another display code which pertains to the loop issue. Refer to the other display code for more information. ELD = Exit Loop Detector OOLD = Outside Obstruction Loop Detector IOLD = Inside Obstruction Loop Detector SLD = Shadow Loop Detector RLD = Reset Loop Detector
FAULT	FAULT 1 MOTOR RUN TIME	1 chirp once every 15 seconds	The STC has detected the motor is on longer than the maximum run time selected. Check and replace drive belt on applicable gate operators. Increase Max Run Timer in the Installer Menu.
ERROR	ERROR 1 DIRECTION ERROR	3 chirps per second once per minute	Close Limit tripped after running Open or Open Limit tripped after running Closed. Assess cables and wire connections. Make sure wires are connected to the proper terminals. Make sure gate handling is appropriate. (Slide gates) Swap connections of hydraulic hoses, if necessary.
ERROR	ERROR 2 IES DISCONNECT	3 chirps per second once per minute	The IES sensor could be bad, check to see that the NC contact is intact. Check that you have the most current sensor; visit our website and view the technical bulletins in the Tech Support area. The sensor wire could be loose; you may want to tighten the female connectors with some pliers. The software may need to be updated. Make sure the brake valves aren't set too tightly by asking, “How fast does the gate panel stop when the limit switch is tripped?” (Tight brake valves will raise the system pressure.)
ERROR	ERROR 3 HYSA COMM ERROR	3 chirps per second once per minute	One or more detectors are not communicating properly. Remove detectors, reset the controller, and re-install detectors one at a time until faulty detector or loop is found.

Table 13: Troubleshooting Codes, Causes and Corrective Action

Type	Alert/Fault/Error Display	Buzzer Chirp Sequence	Possible Cause & Suggested Corrective Action
ERROR	ERROR 4 DUAL GATE	3 chirps per second once per minute	<p>Indicates a problem with the communication between the two gate operators of using Dual Gate configurations. The software versions of these two operators must be the same. Check the version by cycling the power off and on to each operator.</p> <p>NOTE: On power up the software version will flash on the screen (example: h4.53).</p> <p>Make sure the wires are twisted and shielded.</p> <p>Beware of buried high voltage conductors that are too near to the interconnecting conductors, they may interfere.</p> <p>Be sure the installer menu item DG has been configured properly according to the dual gates installed at the site.</p> <p>Error automatically clears when communication fault is resolved.</p>
ERROR	ERROR 6 DRIVE BOARD	3 chirps per second once per minute	Internal error between the STC board and the VFD. Check cable connections and wiring. Make sure both units are working properly.
ERROR	ERROR 7 MENU CHECKSUM Err7	3 chirps per second once per minute	Contact HySecurity.
ERROR	ERROR 8 RPM SENSOR	3 chirps per second once per minute	Check wiring from the hydraulic cylinder to the STC.
FAIL	FAIL PROGRAM DATA ERR FRI L	3 chirps per second once per minute	<ol style="list-style-type: none"> 1. Try turning off the power to the operator and having the customer re-seat all of the various connectors and cables. 2. Upload the latest software release. If the fail does not go away, contact Technical Support.

ACCESS THE EVENT LOG THROUGH THE USER MENU

NOTE: While you are viewing the event log, the gate operator is in Menu mode and cannot run open or close.

1. To enter the User Menu, press the Menu key twice.
2. Press Next and scroll until "LG 0 (OFF)" appears in the display.
3. Press Select. LG blinks.
4. Press Next to change the number to 1,
 LG 1 (ON)
 VIEW EVENT LOG
5. Press Select. The most recent event recorded in the log appears.
6. To scroll through the event log, press Next or Prev.

NOTE: Hold down Next or Prev to scroll quickly toward the top or bottom of the event log.

7. To exit, press Menu. The display resets to LG 0 (OFF).
8. Press Menu again to exit the User Menu and return to Run/Program mode.

Month / Day	Time (HH:MM)	Event Type
03/17	15:27	ALERT 5
Description: ALERT 5: BOTH LIMITS TRIPPED		

NOTE: Over 300 events can be recorded before the software begins overwriting the existing log history.

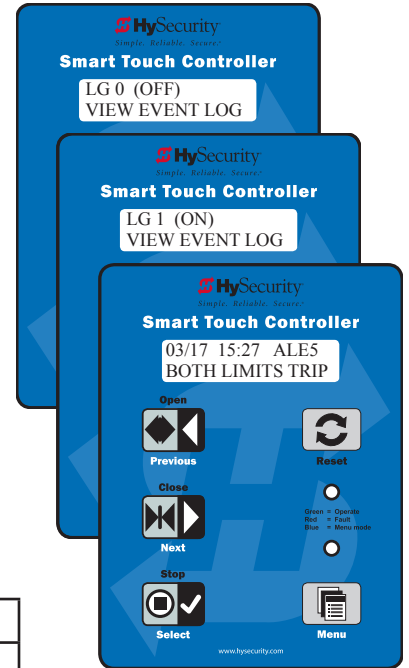

General Maintenance

SMART TOUCH ANALYZE AND RETRIEVE TOOL (S.T.A.R.T.)

HySecurity provides Smart Touch Analyze and Retrieve Tool (S.T.A.R.T.) software to help HySecurity gate operator users and installers conduct the following field service activities:

- Configure installer and user menu settings
- View the operator history (event) log
- Display monitored inputs for operator diagnostics
- Load Smart Touch Controller (STC) software



With S.T.A.R.T. software loaded on your laptop computer, you have an invaluable management tool for all HySecurity operators. The RS-232 serial port (found on the Smart Touch Controller), allows you to download system diagnostics and upload system configurations using the S.T.A.R.T. software. The free S.T.A.R.T. software is conveniently located at www.hysecurity.com. Instructions for downloading S.T.A.R.T. are on the website.

What You Need

HySecurity Serial RS-232 communication cable with USB adapter and current USB driver.

- Laptop computer with Windows PC operating system (XP, Vista, Win7, or Win8)
- Minimum 128MB of RAM
- Minimum 5MB of hard drive disk space
- VGA graphics card (minimum resolution of 800 x 600)

Installing S.T.A.R.T. Software

Read the S.T.A.R.T. User Manual, and then take the following steps to download S.T.A.R.T. software:



The latest version of S.T.A.R.T. is encrypted. An error message will appear stating that the file is corrupt if you try to load new operator code using out-dated S.T.A.R.T. software. Be sure to “uninstall” any outdated versions of S.T.A.R.T. from your laptop and install the latest version from www.hysecurity.com.

1. Bring up your web browser and type <http://www.hysecurity.com> in the command line.
2. Click Technical Support (left column) on the HySecurity home page.
3. Click Download: Smart Touch software.
4. Enter your user name and password. If you do not have a user name, register as an online member.
5. Click S.T.A.R.T. Software for Smart Touch and SmartDC to begin the software download.
6. Read the End User License Agreement. Agree to the terms and click, “**I accept**” (bottom of page).
7. Save the START< >_setup.exe file to your desktop.

8. Double-click the file to begin the installation.
9. Click RUN. A setup window appears.
10. Follow the step-by-step instructions to complete the installation.*
11. When the download is complete, log off the HySecurity website. Shortcuts for the S.T.A.R.T. and STC History Logs appear on your laptop's desktop.

***NOTE:** Confirm you have administrative rights by clicking the following on your computer screen: Windows start ->Control Panel ->User Accounts ->User Accounts. See if your name appears as an administrator. If you are the only user of a computer, you are by default the administrator. If not, you may need to consult with your company's system administrator prior to downloading the HySecurity S.T.A.R.T. program.

SOFTWARE MAINTENANCE

The software on the STC board is periodically being enhanced with new features that create an easier install and improve the on-board diagnostic tools. Be sure to check the HySecurity website for the latest version of software and operator code before heading out for field maintenance.

ELECTRICAL CONTROLS

NOTICE: Before servicing, turn off all power switches.

No routine maintenance is needed for the electrical system or controls. If the environment is very sandy or dusty, or has many insects, be certain to seal all holes in the electrical enclosure. Blow the dust out of the electric panel with compressed air. Use the "Table 13: Troubleshooting Codes, Causes and Corrective Action" on page 54 to assess and fix error, alert, and fault codes. If it is necessary to call a distributor for assistance, be sure to have your model and serial number ready. Other helpful information includes the name of the job, approximate date of installation, and the service record of the operator, especially if any work has been done recently.

Clock Battery Replacement

A lithium coin battery supports the clock, so the date and time is retained even when the main power is turned off. Replace the battery about every five years (or as needed) with a DL 2025, DL 2032, or CR 2025, or CR 2032 battery.

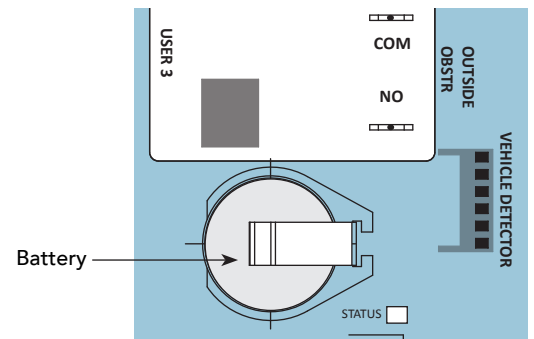

MECHANICAL MAINTENANCE

NOTICE: Before checking the internal mechanisms of the operator, turn OFF all power switches. For maintenance schedule, refer to either "Table 15: HydraWedge SM50 Maintenance Schedule" on page 63 or "Table 16: HydraSupply Maintenance Schedule" on page 64.

HYDRAULIC SYSTEM MAINTENANCE

Fluid Level: Under normal conditions, hydraulic systems do not consume fluid. Check the system thoroughly for leaks, before adding any fluid. If fluid needs to be added:

1. Remove the breather cap from the tank.
2. Use HySecurity Uniflow hydraulic fluid; part number MX000970. Gallon sold by our distributors.
3. Allow the accumulator to drain fully before adding fluid to the tank. If fluid is needed, fill to level line.

NOTE: Never use brake fluid. It will severely damage the hydraulic system. Use of any fluid other than fluid recommended by HySecurity may void the operator warranty.

Look for leaks: Occasionally there may be slight seeping at the fittings after some usage. Tightening of the fittings usually corrects the problem. If leaking persists, replace "O" rings, fittings or hoses, if required. No further leaks should occur.

To Change Fluid: Unlike a gas engine, the fluid inside a hydraulic system does not foul, so fluid changes do not need to occur often. HySecurity recommends draining the reservoir and replacing the fluid at five-year intervals. Fluid breakdown caused by heat is the main concern. If the unit is subjected to high use, or you are using the HySecurity biodegradable fluid option (especially in a warm climate), change the fluid more frequently.

To change the hydraulic fluid,

1. Remove the breather cap from the reservoir tank.
2. Empty the tank by disconnecting the hose from the hand pump. Allow the fluid to flow into a bucket or container and properly dispose of its contents.
3. Clean and wipe the top area around the reservoir tank.
4. Refill tank with Uniflow hydraulic fluid, MX000970.
5. Avoid overfilling. Watch the fluid level indicator. Stop pouring before the top line is reached.
6. Wipe up spilled fluid. Replace the breather cap.

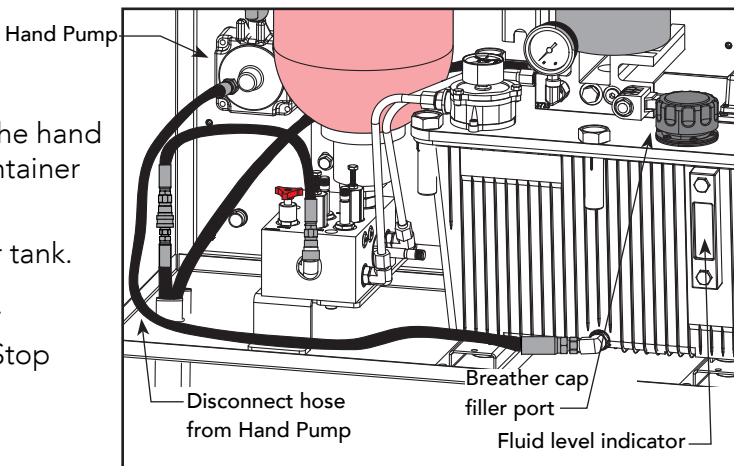

Cold Weather Issues:

1. Check that your reservoir is filled with our Uniflow high performance fluid.
2. Excessive ice buildup can partially or totally jam gate operation. Remove ice and snow buildup before raising (closing) the HydraWedge SM50 blocking plate.
3. If the operator is located in an area of extreme snow conditions, regular maintenance to dig the operator out may be required. A heater option may help.

NOTE: A biodegradable fluid option does exist, but it does not have the same fluid viscosity at extremely low temperatures. Uniflow fluid temperature rating is between -40°F and 158°F (-40°C and 70°C). The biodegradable fluid has a temperature rating between -10°F and 158°F (-23°C and 70°C).

ADJUSTING THE PRESSURE RELIEF VALVE

Pressure relief valve settings differ depending on the model.

NOTE: The pressure relief valve is factory set. Adjustments are only needed when replacing a valve or correcting the factory setting.

Tools Needed: ½" and ⅝" box end wrenches.

Table 14: Pressure Relief Valve Settings

Model	Motor hp	Max PSI Setting	Cut Out Pressure
HydraWedge SM50 with HydraSupply X	2	3000	2900
HydraWedge SM50 with HydraSupply XL Twin	5	3000	2900
HydraSupply XL only (used for power & controls)	5	2600	2500



Never exceed the maximum psi setting.

Make sure the barrier gate is properly installed and aligned before performing the following steps. Take precautionary measures to keep the barrier's travel path clear. The barrier will be in motion while you adjust the pressure relief valve.



DO NOT attempt to adjust the pressure relief valve unless you are an experienced hydraulic gate operator installer. Incorrect pressure settings can cause injury and even death!

1. Expose several threads on the Pressure Relief Valve by loosening the locknut with a ⅝" box end wrench.
2. Use a ½" box end wrench to turn the Adjustment Screw.
3. Press Open or Close to cycle the barrier gate and start the pump.
4. Raise the relief pressure slowly by turning the Adjustment Screw clockwise in ½ turn increments. The Smart Touch Controller software automatically switches the pump off.
5. When the pump switches off, turn the Adjustment Screw clockwise another ½ turn.
6. Lock in the pressure setting. Hold the Adjustment Screw with the wrench and tighten the locknut.

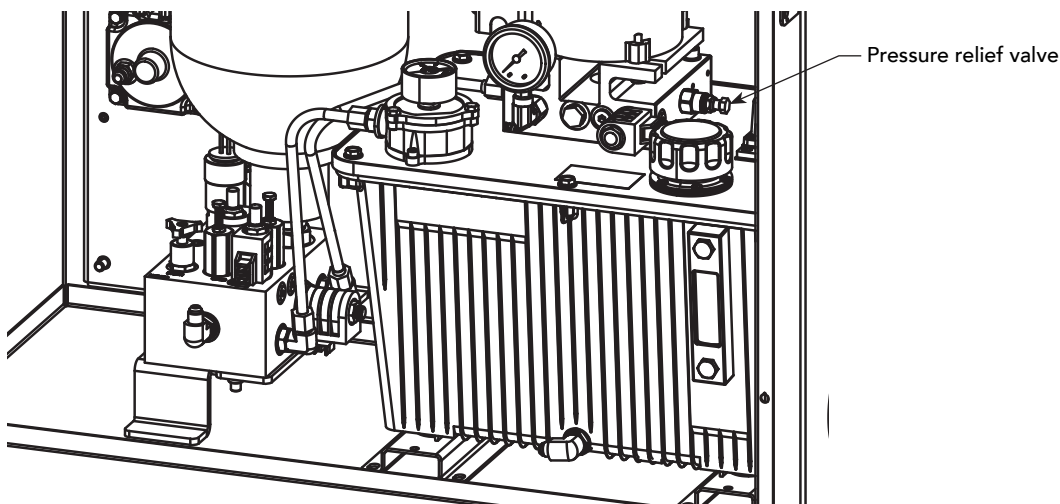

HYDRAWEDGE SM50 MAINTENANCE SCHEDULE

Table 15: HydraWedge SM50 Maintenance Schedule

Name of part	What to do	Weekly	Check at these recommended monthly intervals				
			1	3	6	12	24
Gate and hardware	Check for damage and wear *1	X	X				
Anchor bolts & fasteners	Check and tighten, if loose. If fasteners are worn, replace.	X					
Limit switches	Check adjustment and wear on wires. Repair as necessary *2				X		
Main pivot bearing	Check bearing & pin wear. Replace, if necessary				X		
Cylinder	Apply grease to zerk fittings *3				X		
Scissor joints	Check for wear or excess play				X		
Spring joints	Verify smooth, consistent operation. Replace if necessary		X				
Drainage	Clean area around drain channels and under wedge blocking plate		X				
Drainage channels	Check function of drains under wedge blocking plate		X				

- *1. The wedge blocking plate and hardware require maintenance. A damaged blocking plate or worn hardware may cause slow or erratic operation. Lubricate hardware more frequently and check for smooth operation through scheduled cycle testing. Damaged or warped blocking plate panels should be straightened or replaced. Check for signs of rust or standing water on a monthly basis. The operator chassis is corrosion-resistant, but some environments may increase the rate of corrosion. If any areas of rust are found, reduce the spread of corrosion by treating the areas with a rust inhibitor.
- *2. The limit switch wiring connections exist in the base frame of the wedge barrier and are fed through conduit to the HydraSupply XL control box that houses the Smart Touch Controller. See *"EFO Connections: Wiring Diagram"* on page 17.
- *3 Grease the hydraulic cylinder zerk fittings every 50,000 cycles. Use NLGI #2 Grade Moly EP lithium base grease only and apply it with a standard grease gun.

HYDRASUPPLY XL MAINTENANCE SCHEDULE

Name of part	What to do	Weekly	Check at these recommended monthly intervals				
			1	3	6	12	24
Inspect power unit	Cycle test several times. Listen for unusual sounds or vibrations.		X				
Accumulator	Make visual inspection routine (Watch pressure changes and look for leaks during open & close cycles for at least 30 minutes)		X				
Accumulator*	Regular maintenance, check psi, pressure fittings, consistent volume, etc. *4					X	
Hose inspection	Routinely inspect hoses and replace at least every 5 years				X		
Fluid level	Drain accumulator & check for loss of fluid *5		X			X	
Fluid Leaks	At HPU and Wedge cylinder. Check all hose connections. *6		X				
Hydraulic fluid	Drain and replace fluid (500,000 cycles, or as needed)		X				
Hoses	Check condition and QDs		X				
Pressure gauge	Verify normal pressure		X				
Pressure gauge	Verify Accumulator pre-charge pressure				X		
Fluid filter	Replace, if dirty or plugged.				X		
Inspect Control Box	Visually look inside Control Box. Check for worn wires. Repair wires, remove debris.				X		
Clock battery	Replace *7						X
Motor Brushes (DC Only)	Replace *8						X

Special Notes:

- *4 Accumulator – Drain accumulator and replace fluid at least once every 5 years.
- *5 Fluid Level – Fluid level is normally checked with accumulator drained.
- *6 Fluid leaks – Check for signs of fluid leaks at cylinder and connections inside the HydraSupply XL. Refer to maintenance instructions for fluid filling. Loss of fluid is not normal and indicates a leak that must be located and repaired.
- *7 Replace the Smart Touch Controller coin battery with DL 2025 / DL 2032 or CR 2025 / CR 2032.
- *8 Check the motor. DC motors contain carbon brushes which wear over time and must be replaced. Failure to replace the brushes will result in damage to the DC motor. Brushes should be inspected every year in high usage applications or every 100,000 cycles and replaced as needed

WARRANTY

1. Warranty.

Hy-Security Gate, Inc. ("HySecurity") warrants that at the time of sale each of its products will, in all material respects, conform to its then applicable specification and will be free from defects in material and manufacture.

The following additional durational warranties apply to HySecurity products, depending on whether (1) the product is purchased through an authorized HySecurity distributor and (2) whether a timely and complete product registration is submitted to HySecurity.

It is therefore important that you register your product with HySecurity, (online www.hysecurity.com), within the 60-day period described below.

1(a) HySecurity Products Purchased Through Authorized Distributors and Properly Registered

For any gate operator product that is purchased from an authorized HySecurity distributor (this excludes product purchased through internet resellers or any distributor not authorized by HySecurity), if the product registration is completed by the Dealer/Installer/End User within 60 days of the date of purchase, the following warranty terms will apply. HySecurity warrants that the product will remain serviceable for the following periods:

- a. Hydraulic Industrial Gate Operators: Five Years or 500,000 gate cycles (whichever occurs first) after the date of installation,
- b. Electromechanical Slide and Swing operators: Five Years after the date of installation—unless installed in a single family residential application, in which case the warranty term shall be Seven Years after the date the product is shipped from HySecurity,
- c. Electromechanical Barrier Arm Operators: Two Years or 1,000,000 gate cycles (whichever occurs first) after the date of installation,
- d. Hydraulic Wedge Operators and Electromechanical Surface Mount Wedge Operator: Two Years or 500,000 gate cycles (whichever occurs first) after the date of installation;

provided that the preceding 5-year warranty period in (a) and (b) will not extend beyond seven years from the date that the product was shipped from HySecurity, and the 2-year warranty period in (c) and (d) will not extend beyond four years from the date that the product was shipped from HySecurity.

The preceding warranty durations do not apply to the products or components described below (e-h), which have a shorter warranty period.

- e. Hydraulic Gate Operator Drive Wheels including XtremeDrive™ wheels and rack: Two Years from date of installation.
- f. AC and DC power supplies, chargers and inverters and HyNet module: Two years from date of installation, except batteries.
- g. Batteries: One Year from date of shipment from HySecurity.
- h. Components subject to normal wear including, but not limited to, chains, belts, idler wheels, sprockets and fuses: One Year from date of installation.

1(b) HySecurity Products Not Purchased Through an Authorized Distributor or Not Properly Registered within 60 Days

For any product that is not purchased from an authorized HySecurity distributor or for which the product registration was not completed by the Dealer/Installer/End User within 60 days of the date of purchase, the following One-Year Limited Warranty will apply: HySecurity warrants that the product will remain serviceable for the following periods, which begin on the date that the product was shipped from HySecurity:

- a. All Gate Operators: One Year or 100,000 gate cycles whichever comes first.
- b. AC and DC power supplies, chargers or inverters: One Year.
- c. HyNet module: One Year.
- d. Hydraulic Gate Operator Drive Wheels: One Year.

1(c) Replacement Parts

HySecurity warrants that replacement parts (whether new or reconditioned) will remain serviceable for One Year from the date that the product was shipped from HySecurity or the remaining period of the Gate Operator warranty, whichever is longer.

1(d) Limitations and Exclusions Applicable to Each of the Preceding Warranties.

The preceding warranties shall not apply to equipment that has been (1) installed, maintained, or used improperly or contrary to instructions; (2) subjected to negligence, accident, vandalism, or damaged by severe weather, wind, flood, fire, terrorism or war; or (3) damaged through improper operation, maintenance, storage or abnormal or extraordinary use or abuse. Any modification made to products will

void the warranty unless the modifications are approved in writing by HySecurity in advance of the change (this exclusion does not apply to normal installation of approved accessories and/or protective devices or sensors). It is the responsibility of the distributor, installer, or End User to ensure that the software version in the product is maintained to the latest revision level.

The preceding warranties do not extend to accessories when those items carry another manufacturer's name plate and they are not a part of the base model. HySecurity disclaims all warranties for such accessory components, which carry only the original warranty, if any, of their original manufacturer. HySecurity hereby assigns its rights under such manufacturer warranties—to the extent that such rights are assignable—to Buyer.

These warranties extend to HySecurity's Distributors, to the Dealer/Installer, and to the first End User of the product following installation. They do not extend to subsequent purchasers.

2. Exclusion of Other Warranties.

The warranties contained in Section 1 are the exclusive warranties given by HySecurity and supersede any prior, contrary or additional representations, whether oral or written. Any prior or extrinsic representations or agreements are discharged or nullified. HYSECURITY HEREBY DISCLAIMS AND EXCLUDES ALL OTHER WARRANTIES—WHETHER EXPRESS, IMPLIED, OR STATUTORY—INCLUDING ANY **WARRANTY OF MERCHANTABILITY**, ANY **WARRANTY OF FITNESS FOR A PARTICULAR PURPOSE**, ANY LIABILITY, FOR INFRINGEMENT, AND ANY IMPLIED WARRANTIES OTHERWISE ARISING FROM COURSE OF DEALING, COURSE OF PERFORMANCE, OR USAGE OF TRADE.

3. Buyer's Exclusive Remedies for Any Nonconformity.

If a HySecurity product fails to conform to the warranties in Section 1, Buyer must notify and order replacement parts from the Distributor through which the product was purchased within a reasonable time and in no event more than thirty (30) days after the discovery of the nonconformity. HySecurity will investigate and, in the event of a breach, will provide, within a reasonable period of time, one of the following: (1) repair or replacement of any nonconforming products or components or (2) refund of the price upon return of the nonconforming items. HySecurity reserves the right to supply used or reconditioned material for all warranty claims. HySecurity will not be considered to be in breach of or default under this Warranty because of any failure to perform due to conditions beyond its reasonable control, including any force majeure. This warranty does not cover any incidental expenses, including fines or penalties, temporary security, labor, shipping, travel time or standby time that are incurred for inspection or replacement of any nonconforming items. As a condition of warranty coverage, warranty claims must be submitted in accordance with the procedures described on the HySecurity form, "RMA Procedures."

THE REMEDY SELECTED BY HYSECURITY IN ACCORDANCE WITH THIS PARAGRAPH SHALL BE **THE EXCLUSIVE AND SOLE REMEDY OF BUYER FOR ANY BREACH OF WARRANTY.**

4. Exclusion of Consequential and Incidental Damages.

HYSECURITY SHALL NOT BE LIABLE FOR ANY INCIDENTAL, SPECIAL, OR CONSEQUENTIAL DAMAGES, WHETHER RESULTING FROM NONDELIVERY OR FROM THE USE, MISUSE, OR INABILITY TO USE THE PRODUCT OR FROM DEFECTS IN THE PRODUCT OR FROM HYSECURITY'S OWN NEGLIGENCE.

This exclusion applies regardless of whether such damages are sought for breach of warranty, breach of contract, negligence, or strict liability. This exclusion does not apply to claims for bodily injury or death.

5. Severability.

If any provision of this warranty is found to be invalid or unenforceable, then the remainder shall have full force and effect.

6. Proprietary Rights.

HySecurity retains and reserves all right, title, and interest in the intellectual property rights of its products, including any accompanying proprietary software. No ownership of any intellectual property rights in the products or accompanying software is transferred to Distributor, Dealer/Installer or End User.

7. Applicable Law.

This warranty will be interpreted, construed, and enforced in all respects in accordance with the laws of the State of Washington, without reference to its choice of law principles. The U.N. Convention on Contracts for the International Sale of Goods will not apply to this warranty.

HYDRAWEDGE SM50 & HYDRASUPPLY XL SPECIFICATIONS

Model	HydraWedge™ SM50	HydraWedge™ SM50 UPS	HydraWedge™ SM50 Twin	HydraWedge™ SM50 Twin UPS
Crash Certified	Domestic ASTM F2656 M50-P1 and international IWA 14-1 V/7200[N3C]/80/90:0.0 and PAS68 V/7500[N3]/80/90:0.0/20.7 with no penetration			
Duty Cycle	300 cycles/hr		400 cycles/hr divided between 2 wedges	
Horsepower	2 hp	2 hp	5 hp	4 hp
Drive	Hydraulic			
Open/Close Time	3 seconds			
Emergency Fast Operate	1 second			
Manual Operation	Hand pump (standard)			
Wedge Design	Plate width: 2,2.5, 3, 3.5, 4 m* (6.5, 8, 10, 11.5, 13 ft) Plate height (raised): 1050 mm (3.5 ft) Excavation width: Plate width + 700 mm (27.5 inch) Excavation length: 3.7 m (12 ft) Excavation depth:** 300 mm (1 ft)			
Wheel Load	44,000 lb axle load rating; 22,000 lb wheel load (19,958 Kg. / 9,979 Kg)			
Uninterruptible Power Supply	Standard model generates multiple cycles from fully charged accumulator.	Hundreds of cycles after AC power loss with DC Power Supply w/ HyCharger DC™ ***	Standard model generates multiple cycles from fully charged accumulator.	Hundreds of cycles after AC power loss with DC Power Supply w/ HyCharger DC™ ***
Accumulator Backup Cycles: Either normal or EFO	6 cycles 2.5 gallon accumulator	4 accumulator cycles in addition to hundreds of UPS cycles. 2.5 gallon accumulator	6 cycles divided between two wedges 2.5 gallon accumulator	4 additional accumulator cycles divided between two wedges in addition to hundreds of UPS cycles. 2.5 gallon accumulator
1 Phase Power	208/230V 60Hz 220V 50Hz	115V 60/50Hz 23A † or 208-230V 60/50Hz 11.5A. Choose voltage with care as chargers are not field convertible.	230V 60Hz 220V 50Hz	115V 50/60Hz 23A † or 208-230V 50/60Hz 11.5A. Choose voltage with care as chargers are not field convertible.
3 Phase Power	208/230/460V 60Hz; 220/380/440V 50Hz	n/a	208/230/460V 60Hz; 220/380/440V 50Hz	n/a
Batteries	Two 8Ah batteries maintain low voltage to the controls for 24 hours after AC power loss	Two 110 Ah batteries located in separate DC UPS enclosure	Two 8Ah batteries maintain low voltage to the controls for 24 hours after AC power loss	Two 110 Ah batteries located in separate DC UPS enclosure
Temperature Rating	-40° to 158° F (-40° to 70° C) or -10° to 158° F (-23° to 70° C) HySecurity specified biodegradable fluid			
Communication	RS-232, RS-485, Ethernet/fiber using optional HyNet™ Gateway accessory			
User Controls	Smart Touch Controller with 70+ configurable options. Smart Touch keypad and display or a PC using S.T.A.R.T. software.			
Relays	Three configurable user relays: one 30VDC, 3A solid state and two 250VAC, 10A electromechanical; Optional Hy8Relay™ for 8 additional relay outputs			
Enclosure	HydraSupply XL: Type 3R, 91w x 122h x 41d cm (36w x 48h x 16d inch), optional NEMA 4X	HydraSupply XL: Type 3R, 91w x 122h x 41d cm (36w x 48h x 16d inch), optional NEMA 4X DC Power Supply: Type 3R, 76w x 76h x 30d cm (30w x 30h x 12d inch)	HydraSupply XL: Type 3R, 91w x 122h x 41d cm (36w x 48h x 16d inch), optional NEMA 4X	HydraSupply XL: Type 3R, 91w x 122h x 41d cm (36w x 48h x 16d inch), optional NEMA 4X DC Power Supply: Type 3R, 76w x 76h x 30d cm (30w x 30h x 12d inch)
Finish	Powder coated, 2,000 hr salt spray tested			
Foundation	Less than 300 mm** (1 ft) concrete depth all widths up to 4.15 m (13.5 ft); less than 218 kg (480 lb) rebar; less than 3.1 m3 (4 cu yds) concrete (per wedge)			
Electrical Certification	Control panel certified to UL 508A by ETL			
Warranty	5 year warranty on electronics and hydraulics. 2 year warranty on mechanical wedge.			

* Wedge manufactured in metric scale. Use for precision measurements. All imperial measurements rounded to nearest ½ ft

** 300 mm excavation: 200 mm reinforcing concrete + 100 mm roadway surface of any material

*** The operator's normal duty cycle and the actual number of combined cycles available from batteries depends upon wedge blocking plate weight, number of batteries, state of charge and health, ambient temperature, accessory power draw and length of power outage.

† 115V input requires 30A branch circuit.

Copyright Notice

© Copyright 2016 by HySecurity Gate, Inc.

All rights reserved. No part of this manual may be reproduced by any means (photocopier, electronic, or mechanical), without the express written permission of HySecurity Gate, Inc. Federal copyright law prohibits the reproduction, distribution, or public display of copyrighted materials without the express written permission of the copyright owner, unless fair use or other exemption under copyright law applies. Additionally, HySecurity Gate, Inc. makes no representations or warranty with respect to this manual. We also reserve the right to make changes in the products described without notice and without any obligation to notify any persons of any such revision or change.

Trademarks

SlideDriver, StrongArm, SwingRiser, StrongArm CRASH, StrongArm M30, StrongArm M50, HydraLift, HydraSwing, HydraWedge SM50, HydraSupply XL, HydraSupply, HyNet, Hy8Relay, HyInverter AC, HyCharger DC, SlideWinder, Smart Touch, S.T.A.R.T., SwingSmart DC, SlideSmart DC, StrongArmPark DC, WedgeSmart DC, Smart DC and the HySecurity logo are trademarks or registered trademarks of HySecurity Gate, Inc.

UL and UL logo are trademarks of UL LLC and ETL is a trademark of Intertek.

Intertek provides the ETL Listed Mark.