

New 6" AdvanceDrive Wheels

OPERATORS: SlideDriver™ operator models using 6" AdvanceDrive wheels

DATE: 09/01/2020

SUBJECT: New 6" aluminum AdvanceDrive wheels

SUBJECT DESCRIPTION:

The 6" AdvanceDrive wheels used in SlideDriver models have been replaced with new wheels that do not require a metal retaining plate. The 8" AdvancedDrive and 8" XtremeDrive wheels used in some models will be updated similarly at a later date.

IMPACT:

Simpler disassembly during maintenance.

Figures 1 and 2 (below) show the differences between old and new AdvancedDrive wheel assemblies.

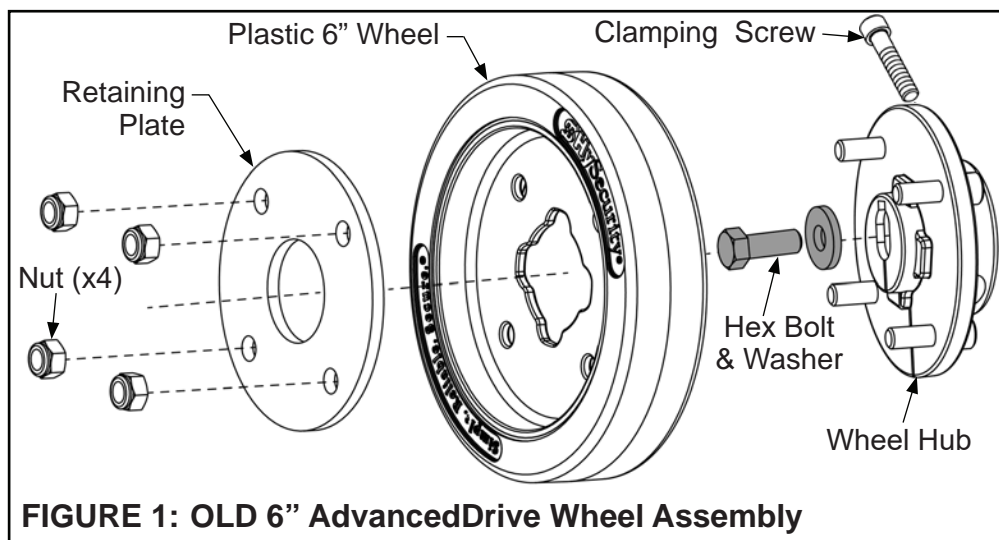

FIGURE 1: OLD 6" AdvancedDrive Wheel Assembly

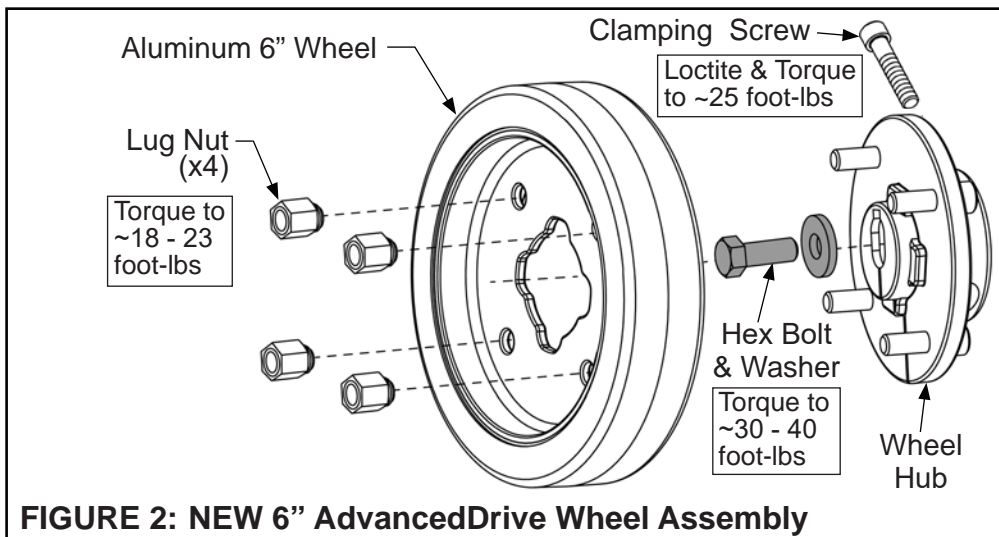

FIGURE 2: NEW 6" AdvancedDrive Wheel Assembly

Part Numbers

Use the part numbers below to order 6" AdvanceDrive replacement kits.

To replace original aluminum wheels use:

P/N MX002707
AdvanceDrive, 6" wheel/hub

- wheel hub
- hub hardware (hex bolt, washer, clamping screw)
- new aluminum wheel
- lug nuts (x4)

To replace plastic wheels use:

P/N MX4994
AdvanceDrive, 6" wheel

- new aluminum wheel
- lug nuts (x4)

To procure lug nuts, use:

P/N MX4993
Lug Nut, 82 Deg, 5/16-24

- lug nuts (x4)

NOTE: New wheels are compatible with the hubs from plastic wheels but require new nuts. If replacing older aluminum wheels they will need a kit with a new hub.

Contact Information:

Visit <https://www.secureopeners.com> for installation manuals, replacement part instructions, part diagrams and more. We are experienced and trained to assist in resolving installation problems. To reach our customer service representatives, call us at (800) 878-7829.

*Before contacting Technical Support, obtain the serial number of your operator.