

SlideSmart™ HD

HD15F, HD25, HD30

Pad or post-mount vehicular slide gate operator with Smart DC Controller



SlideSmart HD:

Table Of Contents.....3

INTRODUCING SLIDESMART HD.....5

Slidesmart Hd Components.....6

Installer's Check List.....7

SAFETY REQUIREMENTS8

Emergency Stop Button.....16

Emergency Release16

INSTALLATION.....17

Site Overview & Planning.....17

Pad Condition.....18

Front Installation.....19

Rear Installation.....20

Unpacking the Operator21

Concrete Pad Mount.....22

Gate Bracket and Chain Installation.....23

Aligning the Chain24

Connecting the Battery and Turning DC Power On25

Programming the Initial Setup Menu25

Establishing the Open & Close Limits27

Installing the Target Magnet28

Front Installation.....29

Rear Installation.....29

POWER30

Installing the Earth Ground.....30

Wiring AC Power31

Wiring 115VAC Power32

Wiring 208/230VAC Power.....33

Important Considerations For DC-Powered Operators.....34

Installing The 50ah Batteries35

Initial Setup.....37

Turning Both Power Switches On.....37

DISPLAY AND MENU OPTIONS.....37

Using the Smart DC Controller Buttons In Menu Mode.....39

Run Mode.....40

Using the Smart DC Controller Buttons in RUN Mode.....40

Viewing Operator Status Displays41

User Menu.....42

Adjusting the Close Timer.....42

Setting the Time and Date.....43

Setting AC Power Loss Gate Function44

Adjusting the Display Contrast45

Installer Menu.....49

Resetting the OPEN and CLOSE Limits.....50

Adjusting Gate Speed.....51

Adjusting the IES Sensitivity.....52

Reinstating Factory Defaults54

Enabling Fire Department Override.....55

SMART DC CONTROLLER.....66

Overview Of The Smart DC Controller67

Vehicle Detector Installation Options.....70

Connecting Hy5b Vehicle Detectors.....71

Install Std. 11-Pin Box Vehicle Detectors73

Connecting Accessory Devices74

Entrapment Sensor Connections.....74

Manual Push Button Station.....75

User Relays - Programming Procedure.....76

BI-PARTING GATE SYSTEMS.....80

Power Requirements.....80

Primary & Secondary Wiring Connections81

Primary And Secondary Menu Setup82

Connecting a Radio RX for Remote Open83

Installing a Maglock or Solenoid Lock83

SENSOR & ACCESS. CONNECTIONS83

Install a Lock for 12-24VDC Systems.....84

Install a Lock for High Voltage Systems84

Installing Vehicle Detectors and Loops.....85

Monitored External Entrapment Sensors.....88

External Entrapment Protection.....90

Photo Eye Installation Tips90

Photo Eye Function91

Edge Sensor Installation Tips.....93

TROUBLESHOOTING.....94

Smart DC Controller Troubleshooting.....94

Vehicle Detector and Loop Fault Diags104

SCHEMATIC107

MAINTENANCE.....108

General Maintenance108

Smart Touch Analyze and Retrieve Tool.....108

What You Need.....108

Installing START Software.....108

Setting User Account Controls.....109

Electrical Controls.....109

Mechanical Maintenance.....109

Software Maintenance.....109

Drive Belt Tension and Alignment.....110

DC Battery Replacement.....111

Clock Battery Replacement.....112

APPX. A - INSTALL CONFIGS.....113

APPX. B - FRENCH TRANS.....119

SLIDESMART HD PART DWGS123

SLIDESMART HD PART LIST.....124

WARRANTY.....125

SLIDESMART HD SPECS.....126

NOTICE

Visit <https://hysecurity.com/technical-support/> for installation manuals, replacement part instructions, part diagrams and more.

INTRODUCING SLIDESMART HD

Thank you for purchasing our premium SlideSmart HD™ slide gate operator. At HySecurity® Gate, Inc., we pride ourselves on quality. Our line of electromechanical gate operators include a number of unparalleled user benefits:

Robust - An especially low flex, corrosion resistant, steel chassis combines with an attractive, key-locked, fade resistant, steel cover. The components on the Smart DC Controller™ are protected by opto-isolators which shield them from power surges and lightning strikes.

Power - The Smart DC Controller provides variable speed control to a powerful, continuous duty 24V DC motor which drives the gearbox. The electronics, motor and gear box are rated to operate in temperatures that range from -13°F to 158°F (-25°C to 70°C). SlideSmart HD 15F is rated for slide gates up to 50 feet long and 1,500 pounds (15m and 680.3kg). SlideSmart HD 25 is rated for slide gates up to 50 feet long and 2,500 pounds (15m and 1,134kg). SlideSmart HD 30 is rated for slide gates up to 50ft and 3,000lbs. (15m and 1,361kg).

Finesse - A variable rate of gate acceleration and deceleration, dependent upon gate weight and length, assures very smooth handling.

UPS backup - Two 12V, 8 amp hour (Ah) batteries will provide a fully functional gate operator (up to 4000ft/1219m of gate travel) when AC power is unavailable. Four user-selectable UPS modes are available. 12VDC and 24VDC are available to power accessory controls. Removable 8Ah battery tray and hardware provides space for the optional 50Ah batteries which support usage during extended power outages.

INTELLIGENT FEATURES: SMART DC CONTROLLER™

Menus and User relays - The Smart DC Controller has over 55 menu items to allow installer configuration of gate function and two user relays, which can be configured for over 30 different functions.

Independent adjustment for open and close gate speeds - An easy-to-use menu on the Smart DC Controller allows the installer to independently vary the open and close speed settings.

Intelligent Inherent Entrapment Sensor (IES) - Any impediment to gate travel is sensed by the system, stopping gate movement per UL 325 Safety Standards. The intelligent system monitors gate power then adapts the IES to trip at an adjustable threshold above normal power.

Liquid Crystal Display (LCD) - A 32-character LCD provides increased readability for programming and troubleshooting.

USB communications port - A direct connect provides accessibility to download system diagnostics and upload system configurations using the Smart Touch Analyze and Retrieve Tool (START) software.

START software and diagnostics - With START software loaded on a laptop computer, you can get the latest software upgrade and have an invaluable troubleshooting tool for all HySecurity operators. To download this free software, visit the HySecurity website at www.hysecurity.com.

TECHNICAL SUPPORT

For technical support, call your installer or authorized HySecurity distributor. Obtain the serial number of your operator before calling. Refer to "SlideSmart HD Components" on page 4. For the name of a distributor near you, call HySecurity at 800-321-9947.

For information about HySecurity training for installers, maintenance personnel and end users, refer to the company website at www.hysecurity.com or call 800-321-9947.

SLIDESMART HD COMPONENTS

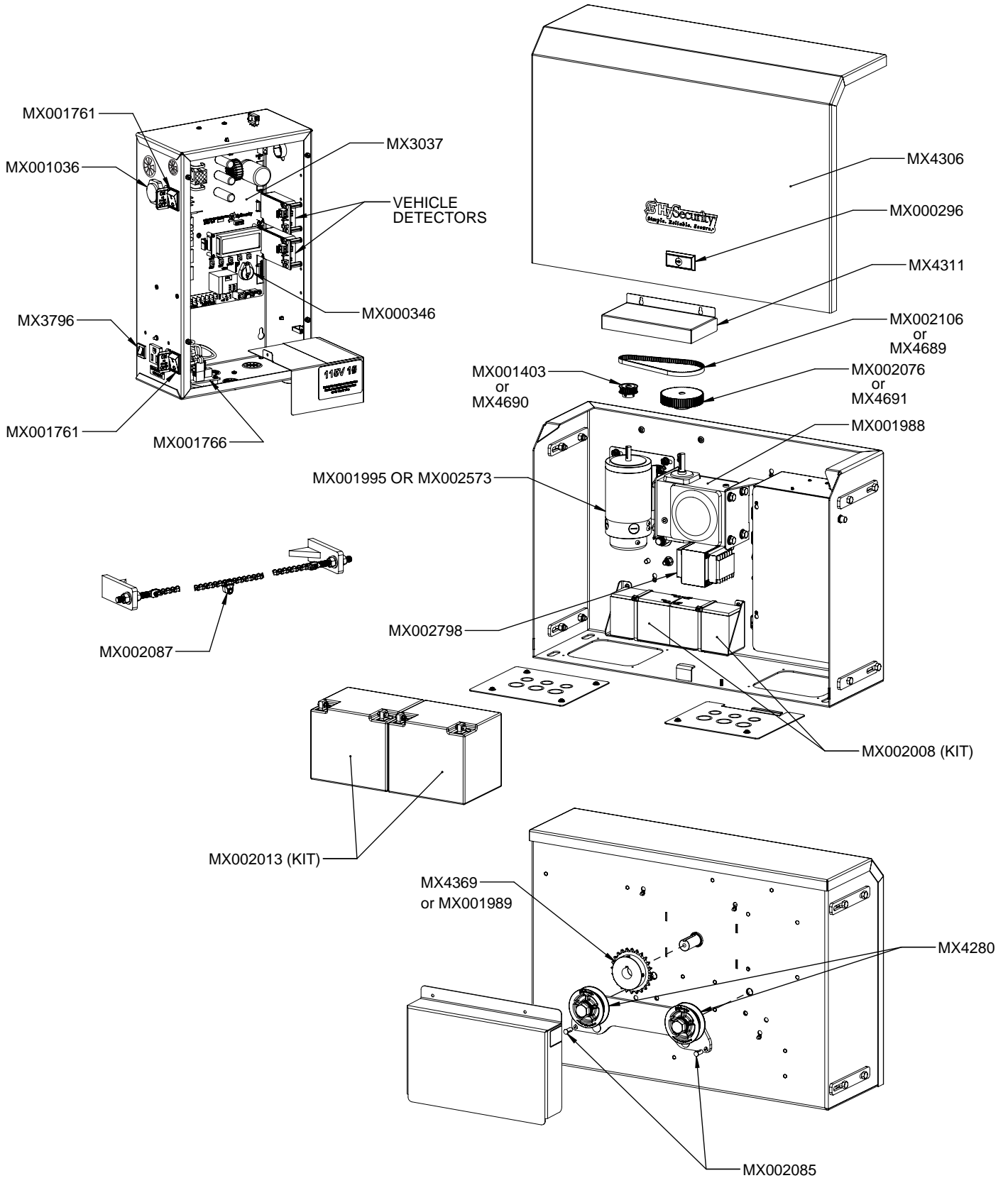

INSTALLER'S CHECK LIST

The following list provides a high level overview of the tasks involved in installing the SlideSmart HD gate operator. Take a moment to review the list and check off the items as you complete the install.

- Site Prep - concrete pad location/dimensions, distance from gate, chain height, and mounting considerations: post or base extension, front or rear installation.
- Make sure gate installation complies with ASTM F2200 Standard Specification for Automated Vehicular Gate Construction. And, install the supplied WARNING sign on both sides of the gate.
- Check for compliance with local codes, site conditions, and NEC standards.
- Install operator - (on concrete pad use operator and conduit area cut outs as template)
- Attach chain end brackets to gate at proper height.
- Attach chain to end brackets and feed under SlideSmart idlers and over chain sprocket.
- Tighten chain using tensioning bolts.
- Verify chain is level with idlers and parallel to operator and gate.
- Connect red wire to DC Power Switch.
- Turn DC Power ON.
- Complete Initial Setup Menu programming.
- Install the target magnet and make sure it is in line with and passes by the target sensor so it can be recognized by the software programming.
- Connect AC Power.
- Connect all accessory devices
- Adjust the Close Timer (through the User Menu).
- Set gate speed, if applicable (through Installer Menu). Refer to START ("*Smart Touch Analyze and Retrieve Tool*" on page 106).
- Set IES sensitivity, if needed (through Installer Menu).
- Check the Smart DC Controller software version. If needed, upload the latest version from www.hysecurity.com. See "*Smart Touch Analyze and Retrieve Tool*" on page 106..
- Program changes through the Installer Menu depending on the accessory devices that you have installed.
- Give a copy of the operator instructions to the end user. Show the end user how to:
 - Remove the operator cover. Turn the power off and on to demonstrate learn limits after DC/AC cycles.
- Turn the DC power switch off, which disengages the motor, and manually push the gate.
 - Test the black Emergency Stop Button located on the side of the cover. It can be accessed through a hole in the cover. See Figure 1 on page 14.
- Take photographs of the completed installation site and save it in your business files.
- Install external entrapment sensors as needed.

SAFETY REQUIREMENTS

SAFETY MESSAGES

The safety messages below inform you about potential hazards that can result in injury. Safety messages specifically address level of exposure to operator and are preceded by one of four words: **DANGER, WARNING, CAUTION** or **NOTICE**.

 **DANGER**

Indicates a hazardous situation which, if not avoided, **WILL** result in **DEATH** or **SERIOUS INJURY**.

 **WARNING**

Indicates a hazardous situation which, if not avoided, **COULD** result in **DEATH** or **SERIOUS INJURY**.

 **CAUTION**





Indicates a hazardous situation which, if not avoided, **COULD** result in **MINOR** or **MODERATE INJURY**.

NOTICE

Addresses practices not related to personal injury. Indicates damage to equipment is probable if the hazardous situation is not avoided.

COMMON INDUSTRIAL SYMBOLS

These international safety symbols may appear on product or in its literature to alert of potential personal injury hazards. Obey all safety messages that follow these symbols to avoid possible injury or death.

Symbol	Safety Hazard
	Attention - Take Notice
	Danger - Keep Away
	Entrapment Zone
	Possible Pinch Point

IMPORTANT SAFETY INSTRUCTIONS

Hazards, associated with automatic gates, can be reduced with proper site design, installation, and use. Installers, maintenance crews, and owners/users must read and follow the safety requirements found in HySecurity® product manuals.



It is important that only qualified installers handle installation of HySecurity Gate vehicular gate operators. A “qualified” installer has one of the following:



1. A minimum of three years experience installing similar equipment.
2. Proof of attending a HySecurity Technical Training seminar within the past three years.
3. Significant manufacturer endorsements of technical aptitude in gate operator installation and operation.

Underwriter Laboratories (UL) and the American Society for Testing and Materials (ASTM) are responsible for current safety standards and regulations regarding gate operators and automated gates. All aspects of gate installation must comply with the appropriate safety standard. For the most up-to-date ASTM F2200 Gate and Fence Standards, refer to www.astm.org. For UL 325 Safety Standard, refer to www.ul.com. Consult local government agencies for up-to-date rules and regulations as certain municipalities have established licensing, codes or regulations that regulate automated gate system design and installation.

GENERAL SAFETY INFORMATION

A gate operator is only a component in a gate system. The other parts of the gate system can include the gate, the external safety sensors, access controls, and vehicle detectors. To have a gate system that provides for safety, security, and reliable operation it is essential these components operate together as a system. It is the responsibility of the system designer and/or installer to ensure any safety or operational issues have been addressed.



WARNING

To reduce the risk of injury or death:

1. READ AND FOLLOW ALL INSTRUCTIONS.
2. Never let children operate or play with gate controls. Keep the remote control away from children.
3. Always keep people and objects away from the gate. **NO ONE SHOULD CROSS THE PATH OF THE MOVING GATE.**
4. Test the gate operator monthly. The gate **MUST** reverse on contact with a rigid object or stop when an object activates the non-contact sensors. After adjusting the force or the limit of travel, retest the gate operator. Failure to adjust and retest the gate operator properly can increase the risk of injury or death.
5. Use the emergency release only when the gate is not moving.
6. **KEEP GATES PROPERLY MAINTAINED.** Read the user's manual. Have a qualified service person make repairs to gate hardware.
7. The entrance is for vehicles only. Pedestrians must use separate entrance.
8. **SAVE THESE INSTRUCTIONS.**

IDENTIFYING GATE OPERATOR CATEGORY AND UL 325 USAGE CLASS

The UL 325 standard covers gate operators. Within this safety standard several Usage Classes are described that define different types of installations where gate operators can be applied. Some operators are restricted in their usage application. Appropriate Usage Classes are shown in the Specifications.

Class I



Class I: Intended for use in a location of one to four single family dwellings or a parking area associated with one to four single family dwellings.

Class II



Class II: Intended for use in a commercial location or building such as a multi-family housing units (five or more single family units) hotels, garages, retail stores or other buildings servicing general public.

Class III

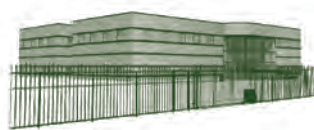

Class III: Intended for use in an industrial location or building such as factories or loading docks or other locations not accessible by the general public.

Class IV



Class IV: Intended for use in guarded industrial locations or buildings such as an airport security area or other restricted access location, not servicing general public, in which access is monitored by security personnel or via closed circuitry.

VEHICULAR TRAFFIC ONLY

WARNING

This automatic gate operator is not designed nor is it intended for pedestrian traffic. Vehicular gate operators must by their nature be powerful to function reliably. This power can cause injury or death. Accordingly, direct all pedestrian traffic to a separate walk-through gate.

Install this gate operator only when:

- The operator is appropriate for the construction of the gate and the usage Class of the gate.
- All openings of a horizontal slide gate are guarded or screened from the bottom of the gate to a minimum of 1.83 m (6 ft) above the ground to prevent a 57.2 mm (2-1/4 in) diameter sphere from passing through the openings anywhere in the gate, and in that portion of the adjacent fence that the gate covers in the open position.
- All exposed pinch points are eliminated or guarded.
- Guarding is supplied for exposed rollers.

The operator is intended for installation only on gates used for vehicles. Pedestrians must be supplied with a separate access opening. The pedestrian access opening shall be designed to promote pedestrian usage. Locate the gate such that persons will not come in contact with the vehicular gate during the entire path of travel of the vehicular gate.

The gate must be installed in a location so that enough clearance is supplied between the gate and adjacent structures when opening and closing to reduce the risk of entrapment. Swinging gates shall not open into public access areas.

The gate must be properly installed and work freely in both directions prior to the installation of the gate operator. Do not over-tighten the operator clutch or pressure relief valve to compensate for an improperly installed, improperly functioning, or damaged gate.

Permanently mounted controls intended for user activation must be located at least 1.83 m (6 ft) away from any moving part of the gate and where the user is prevented from reaching over, under, around or through the gate to operate the controls.

- Exception: Emergency access controls only accessible by authorized personnel (e.g. fire, police, EMS) may be placed at any location in the line-of-sight of the gate.

The Stop and/or Reset button must be located in the line-of-sight of the gate. Activation of the reset control shall not cause the operator to start.

A minimum of two (2) WARNING SIGNS shall be installed, in the area of the gate. Each placard is to be visible by persons located on the side of the gate on which the placard is installed.

For gate operators utilizing a non-contact sensor (Photo Eye):

- See instructions on the placement of non-contact sensors for each type of application.
- Care shall be exercised to reduce the risk of nuisance tripping, such as when a vehicle trips the sensor while the gate is still moving.
- One or more non-contact sensors shall be located where the risk of entrapment or obstruction exists, such as the perimeter reachable by a moving gate or barrier.

For a gate operator utilizing a contact sensor (Edge):

- One or more contact sensors shall be located where the risk of entrapment or obstruction exists, such as at the leading edge, trailing edge, and postmounted both inside and outside of a vehicular horizontal slide gate.
- A hardwired contact sensor shall be located and its wiring arranged so that the communication between the sensor and the gate operator is not subjected to mechanical damage.
- A wireless device such as one that transmits radio frequency (RF) signals to the gate operator for entrapment protection functions shall be located where the transmission of the signals are not obstructed or impeded by building structures, natural landscaping or similar obstruction. A wireless device shall function under the intended end-use conditions.
- One or more contact sensors shall be located on the inside and outside leading edge of a swing gate. Additionally, if the bottom edge of a swing gate is greater than 152 mm (6 in) but less than 406 mm (16 in) above the ground at any point in its arc of travel, one or more contact sensors shall be located on the bottom edge.

USE OF VEHICLE DETECTORS

Use of vehicle detectors (loop detectors) is strongly encouraged to prevent damage to vehicles caused by gates closing on them. This is not considered to be a safety item as vehicle detectors cannot provide protection to pedestrians. In some situations, photoelectric devices may be used as vehicle detectors, but should be wired accordingly.

GATE CONSTRUCTION AND SAFETY

Gate construction plays a very important role in ensuring the safety of any automated gate system. The standard for gate construction is ASTM F2200. Below are key areas to address in gate design for safety. For complete information consult the standard. Copies of the standard are available at:

<https://www.astm.org/Standards/F2200.htm>. MX4435 Rev. E ©2020

Another source of information is available from DASMA, the Door and Access System Manufacturer's Association. The Association publishes Technical Data Sheets, one of which concerns ASTM F2200. For more information, see:

<http://www.dasma.com/PDF/Publications/TechDataSheets/OperatorElectronics/TDS370.pdf>.

General Requirements for gate construction:

- Gates shall be constructed in accordance with the provisions given for the appropriate gate type listed. Refer to ASTM F2200 for additional gate types.
- Gates shall be designed, constructed and installed to not fall over more than 45 degrees from the vertical plane, when a gate is detached from the supporting hardware.
- Gates shall have smooth bottom edges, with vertical bottom edged protrusions not exceeding 0.50 in (12.7 mm) other than the Exceptions listed ASTM F2200.
- The minimum height for barbed wire shall not be less than 6 ft (1.83 m) above grade. The minimum height for barbed tape shall not be less than 8 ft (2.44 m) above grade.
- An existing gate latch shall be disabled when a manually operated gate is retrofitted with a powered gate operator.
- A gate latch shall not be installed on an automatically operated gate.
- Protrusions shall not be permitted on any gate. Consult ASTM F2200 for exceptions.
- Gates shall be designed, constructed and installed such that their movement shall not be initiated by gravity when an automatic operator is disconnected.
- For pedestrian access in the vicinity of an automated vehicular gate, a separate pedestrian gate shall be provided. The pedestrian gate shall be installed in a location such that a pedestrian shall not come in contact with a moving vehicular access gate. A pedestrian gate shall not be incorporated into an automated vehicular gate panel.
- Any non-automated gate that is to be automated shall be upgraded to conform to the provisions of this specification.
- This specification shall not apply to gates generally used for pedestrian access and to vehicular gates not to be automated.
- Any existing automated gate, when the operator requires replacement, shall be upgraded to conform to the provisions of this specification in effect at that time.

The following provisions shall apply to Class I, Class II, Class III, and Class IV vehicular horizontal slide gates:

All weight bearing exposed rollers 8 ft (2.44 m), or less, above grade shall be guarded or covered.

All openings shall be designed, guarded, or screened from the bottom of the gate to the top of the gate or a minimum of 72 inch (1.83 m) above grade, whichever is less, to prevent a 2-1/4 inch (57 mm) diameter sphere from passing through the openings anywhere in the gate, and in that portion of the adjacent fence that the gate covers in the open position. The gate panel shall include the entire section of the moving gate, including any back frame or counterbalance portion of the gate.

A gap, measured in the horizontal plane parallel to the roadway, between a fixed stationary object nearest the roadway (such as a gate support post) and the gate frame when the gate is in either the fully open position or the fully closed position, shall not exceed 2-1/4 inches (57 mm).

Exception: All other fixed stationary objects greater than 16 inches (406 mm) from the gate frame shall not be required to comply with this section.

Positive stops shall be required to limit travel to the designed fully open and fully closed positions. These stops shall be installed at either the top of the gate, or at the bottom of the gate where such stops shall horizontally or vertically project no more than is required to perform their intended function.

All gates shall be designed with sufficient lateral stability to assure that the gate will enter a receiver guide. Consult ASTM F2200 for details on various gate panel types.

SECONDARY ENTRAPMENT PROTECTION SENSORS

Most HySecurity gate operators are equipped with a Type A, Inherent Entrapment Sensor (IES). UL 325 Safety Standard compliance requires installation of external entrapment protection sensors, the number of which, depends on entrapment hazards that exist at each particular installation.

To comply with UL 325, the following external sensors may be used:

- Contact sensors, such as edge sensors
- Non-contact sensors, such as photo eyes

Site designer or installer can choose either photo eyes, edge sensors, or a combination of these devices. Whatever devices are used, protection in both opening and closing directions of gate travel must be provided.

UL 325 Safety Standard for automatic sliding gates specifically requires that edge sensors, photo eyes, or a combination of both devices be installed to protect against pedestrian entrapment in BOTH directions of gate travel and wherever entrapment hazards exist.

SAFETY REQUIREMENTS

PHOTO EYES: One or more non-contact sensor (photo eyes) shall be located where entrapment risk or obstruction exists, such as perimeter reachable by a moving gate.

Care shall be exercised to reduce the risk of nuisance tripping, such as when a vehicle trips the sensor while the gate is moving.

EDGE SENSORS: One or more contact sensors (edge sensors) shall be located at leading edge, trailing edge, and post-mounted, both inside and outside of a sliding gate.

One or more contact sensors shall be located on the inside and outside leading edge of a swing gate. Additionally, if the bottom edge of a swing gate is greater than 6" (152mm) but less than 16" (406mm) above the ground at any point in its arc of travel, one or more contact sensors shall be located on the bottom edge.

SENSOR SECURITY: A hard-wired contact sensor shall

CAUTION

A contact or non-contact sensor is also required to protect against possible entrapment if gate opens to a position less than 16 inches from any object, such as a post or wall.

be located and its wiring arranged so that communication between sensor and gate is not subjected to mechanical damage.

SENSOR FUNCTION and COMMUNICATION: A sensor that transmits its signal to gate operator must be located so its signal is not impeded by building structures or other obstructions. All sensors must be installed so that they function as intended for end-use conditions.

UL 325 LISTING: Edge sensors and photo eyes must be tested and labeled as "Recognized Components" or otherwise certified to UL 325 requirements in order to be deemed acceptable for use in a gate operator. Study Important Safety Instructions and consider your specific installation to determine where greatest entrapment risks exist. Locate edge sensors and/or photo sensors accordingly. Be certain that a sufficient number of sensors are used so that pedestrians are protected from entrapment in both directions of gate travel and all hazard areas are fully protected. Most HySecurity gate operators require external entrapment sensors that utilize Normally Closed (NC) contact means of monitoring. HySecurity gate operators utilizing the SmartCNX Controller require external entrapment sensors that have a 10k Ohm or 4-wire pulsed monitoring scheme. Refer to UL website at www.ul.com for most up-to-date list of gate operator safety standards (UL 325). Refer to www.astm.org for a complete list of ASTM F2200 Gate and Fence Standards.

UL 325

Use of Approved External Entrapment Protection Sensors is REQUIRED

Gate operator will not automatically cycle the gate unless an indication that the appropriate number of external entrapment protection sensors are connected and operational.

The normally closed (NC) entrapment protection sensors wired to the Controller's SENSOR inputs are monitored using HySecurity software. Prompts appear on the display requesting specific configurations based on the gate operator type.

Effective August 1st, 2018, the UL 325 Standard has changed:

- The operator shall monitor for the presence of every device at least once during each open and close cycle (32.1.8)
- It shall not be possible to make simple modifications in the field by adding, suppressing or changing, either on the operator or external entrapment protection device(s), to bypass, interfere with, or otherwise defeat the monitoring function. (32.1.10)
- Entrapment zones are now defined for each gate type (4.23, 4.24, 4.29, 4.34)

SLIDE GATES: To enable fully automatic operation, all SLIDE gate operators will require a minimum of TWO monitored external entrapment protection sensors (one for each direction) to protect entrapment zones in both the open and close direction of travel.

Preferred solution for slide gates: A photo eye for the close direction and a hard-wired edge sensor for the open direction that is mounted to the face of the leading post of the fence behind the gate. (Reach through injuries are the most common hazard associated with automatic sliding gates)

SWING GATES: To enable fully automatic operation, all SWING gate operators will require a minimum of ONE monitored external entrapment protection sensor to protect entrapment zones in either the open or close direction of travel. However, an additional monitored sensor is required if there is a risk of entrapment in both directions of gate travel.

Preferred solution for swing gates: A photo eye for the close direction and/or a hard-wired wraparound edge sensor on the leading edge of the gate, which protects for both directions of gate travel.

SAFETY REQUIREMENTS

The following sensors have been tested with HySecurity gate operators by an independent laboratory and certified to comply with UL 325 7th Edition. Select sensors from this list for UL compliant gate automation solutions. Contact the sensor manufacturer for specific recommendations for use.



All external entrapment protection sensors must have NC sensor outputs and be wired to the SENSOR COM terminal for monitoring and powering purposes. Depending on software version, the sensor becomes powered when the gate operator's motor runs or is always powered when the operator is connected to AC power.

HySecurity Recommended Sensors				
	Mfg. Part #	Mfg.	Details	Hysecurity Part #
Photo Eyes (Retroreflective)	E3K-R10K4-NR	Omron	40 ft max range limit	MX000999
	NIR-50-325	EMX	45 ft max range limit	
	IRB-RET	EMX	53 ft max range limit	
	E-931-S50RRGQ	Seco-Larm	45 ft max range limit	
Photo Eyes (Thru-Beam)	IRB-MON*	EMX	65 ft max range limit	MX3990
	E-960-D90GQ	Seco-Larm	90 ft max range limit	
Edge Sensors	Sentir Series**	ASO Safety	Channel mount, high profile Channel mount, low profile Round, wraparound Square, wraparound	AS1502-0440-05 AS1502-0430-05 AS1501-0760 AS1501-0790
	CPT210-2U-4-T2	Miller Edge	10k resistor termination (replace # with length requirement in feet)	
Edge Sensor, Converters (10K to NC Contact)	Hy2NC	HySecurity	2-channel edge converter	MX4018
Edge, Wireless Kits	IGAZE RE Kit	Transmitter Solutions	50 ft line of sight max range limit	
	WEL-200 (kit with receiver and transmitter)	EMX	200 ft line of sight max range limit	
Multi-input Module	The Solution – MIM-62	Miller Edge	6 inputs to 2 outputs	

*IRB-MON photo eyes are pre-bundled with HySecurity SwingSmart DC, SlideSmart DC and SlideDriver operators.

**Sentir Series ASO edge sensors are pre-bundled with HySecurity SlideSmart DC, SlideSmart CNX and SlideDriver operators.

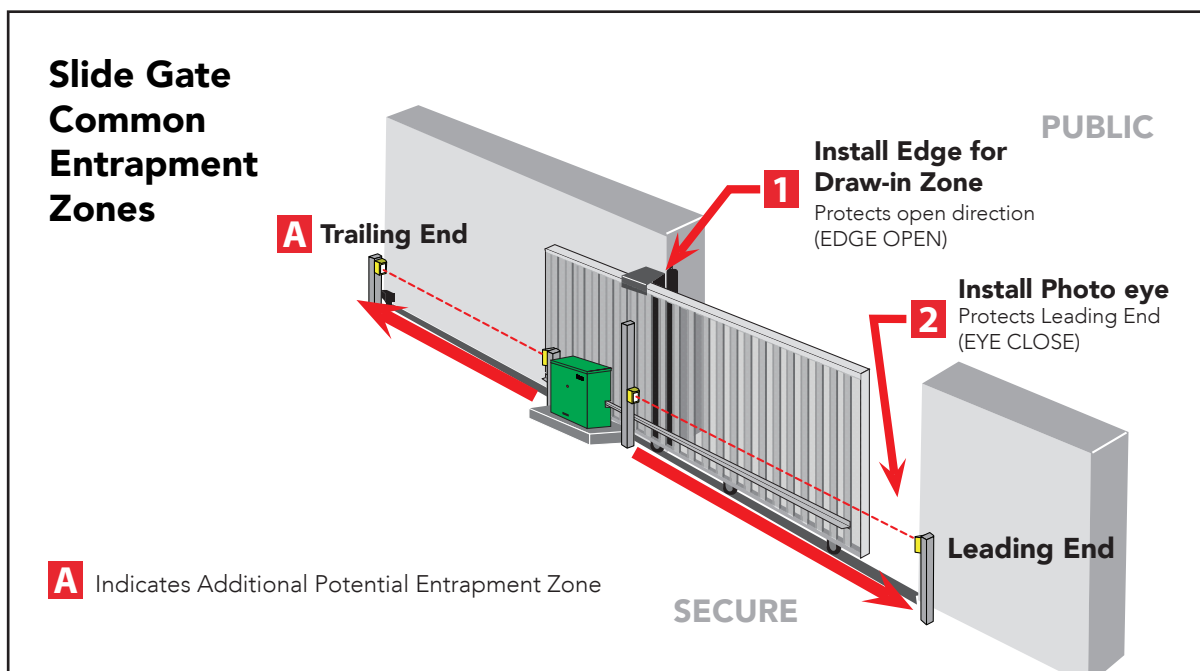

Installers must assess each specific site and install sensors that protect all potential entrapment zones.

For more information visit Gate Safety at www.hysecurity.com/gatesafety or see latest operator manual at www.hysecurity.com/contact-us/technical-support/installation-manuals



SAFETY REQUIREMENTS

ELECTRICAL SAFETY

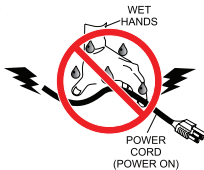
- Turn gate operator and all circuit breakers OFF before performing maintenance on the gate operator or making contact with output receptacles. 
- Never insert any objects into output receptacles during operation. The possibility exists of electrical shock, electrocution, or death. 
- Never let power wires lay in water.
- Never use damaged or worn wire when connecting equipment. Inspect for cuts in the insulation.
- Never grab or touch a live power cord or cable with wet hands. The possibility exists of electrical shock, electrocution or death. 
- Always make certain that proper power has been selected for the job. See Cable Selection Chart in this manual.

GROUNDING SAFETY

- Always make sure that electrical circuits are properly grounded to a suitable earth ground (ground rod) per the National Electrical Code (NEC) and local codes. Severe injury or death by electrocution can result from operating an ungrounded operator. 
- Never use gas piping as an electrical ground.





BATTERY SAFETY

HySecurity operators use sealed Absorbed Glass Mat (AGM) batteries and HySecurity highly recommends replacing used batteries with new AGM-type batteries.

CAUTION

Batteries used with HySecurity gate operator contain materials considered hazardous to environment. Proper battery disposal is required by federal law. Refer to *Hazardous Waste Regulations* federal guidelines.

To reduce risk of fire or injury to persons:

- Observe polarity between batteries and charging circuit.
- Never mix battery sizes, types, or brands. Charging circuit on HySecurity DC operators is designed for AGM-type batteries, not flooded lead acid-type batteries.
- Exercise care in handling batteries. Be aware metal found in rings, bracelets, and keys can conduct electricity, short batteries, and cause potential injury. 
- Do not open or mutilate batteries. Battery cells contain corrosive materials which may cause burns and other injuries. Material within batteries is toxic. 
- Always dispose of batteries properly. Do not place batteries in fire. Battery cells may explode. Follow federal guidelines for proper disposal of hazardous waste. 
- Always keep battery cables in good working condition. Repair or replace all worn cables.
- Replace batteries according to instructions found in *DC Battery Replacement*. 
- Do not charge frozen battery. Battery can explode. If frozen, warm the battery to at least 61°F (16°C).

ENVIRONMENTAL SAFETY/ HAZARDOUS MATERIALS AND PROPER DISPOSAL

Decommissioning is a controlled process used to safely retire a piece of equipment that is no longer serviceable. If the equipment poses an unacceptable and unreparable safety risk due to wear or damage or is no longer cost effective to maintain (beyond life-cycle reliability) and is to be decommissioned (demolition and dismantlement), be sure to follow rules below. 

- Do not pour waste or oil directly onto the ground, down a drain or into any water source.
- Contact your country's Department of Public Works or recycling agency in your area and arrange for proper disposal of any electrical components, waste or oil associated with this equipment.
- When the life cycle of this equipment is over, remove battery and bring to appropriate facility for lead reclamation. Use safety precautions when handling batteries that contain sulfuric acid.
- When the life cycle of this equipment is over, it is recommended that the frame and all other metal and plastic parts be sent to a recycling center.

Metal and plastic recycling involves the collection of metal and plastic from discarded products and its transformation into raw materials to use in manufacturing a new product.

Recyclers and manufacturers alike promote the process of recycling metal and plastic. Using a metal and plastic recycling center promotes energy cost savings.

WIND LOAD FACTORS & SITE PREP

Wind load is always a factor when considering the appropriate gate for a particular site. Solid gate panels produce a larger wind load than gates with slats or open decorative features. If you are installing a gate operator in a high wind area, gate design will affect the load on the gate operator because wind load acts the same as an obstruction. Good gate panel design presents a low surface area to reduce the wind load.

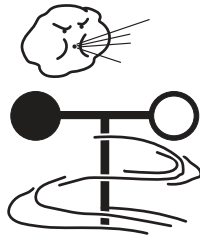

If gate is heavy and near weight capacity of what the gate operator can handle (see specifications), make sure it has an open design that allows wind to flow through it. A solid or semi-solid gate design under certain wind load conditions may cause damage to gate operator and is not covered by the HySecurity Limited Warranty.

Several factors play into calculations of wind load on a gate panel. To find out maximum wind speed in areas around the United States, search for US government wind speed maps on the internet. If you don't know how to calculate for wind load, ask a mechanical engineer or site architect for assistance prior to installing gate operator and gate panels.

When the IES trips, it sends a signal to gate operator to stop and reverse direction. This feature may be falsely triggered in excessively windy conditions because wind itself, acting over surface area of gate panel, can provide necessary force to trigger IES.

CAUTION

Do not adjust IES sensitivity to accommodate for inappropriately designed gate panels. Loss of IES sensitivity increases mechanical wear on gate hardware and gate operator. It may also pose a safety hazard. Compensating for wind loads by adjusting IES may set IES sensitivity to a level which, when encountering an obstruction, ignores obstruction and fails to reverse direction. For more information, refer to Adjusting the IES Sensitivity.

MAINTENANCE OF GATE SYSTEMS

To keep your automated gate system performing both safely and reliably it is important to ensure that the components of that system are functioning properly.

At least monthly:

- Disconnect the gate operator and manually move the gate through its range of travel. Note any squeaks from rollers or hinges or areas of binding. The gate should travel smoothly and quietly throughout its range. If it does not, contact a gate professional to correct the problem.
- Reconnect the gate operator and perform the following tests:
 - With the gate opening, block any photo eyes and/or depress any safety edges used to protect the open direction. The gate should stop and/or reverse.
 - With the gate closing, block any photo eyes and/or depress any safety edges used to protect the close direction. The gate should stop and/or reverse.
 - Using a suitable obstruction in the path of the gate (a solid, immovable object), run the gate in the open direction until it contacts the obstruction. The gate should stop and reverse.
 - Using a suitable obstruction in the path of the gate (a solid, immovable object), run the gate in the close direction until it contacts the obstruction. The gate should stop and reverse.

EMERGENCY STOP BUTTON

An emergency stop button is accessible from the outside of the operator. The black emergency stop button is located on the right face of the chassis. See Figure 1.

Pressing the emergency stop button while the gate is opening or closing disables the automatic close timer and stops gate travel. The gate travel remains stopped until the operator receives an open or close signal.

Make sure all users of the gate know where the emergency stop button is located.

Pressing the emergency stop button during Entrapment Mode resets the operator to Safe Mode and begins gate operation. Ensure the gate path is clear before resetting Entrapment Mode.

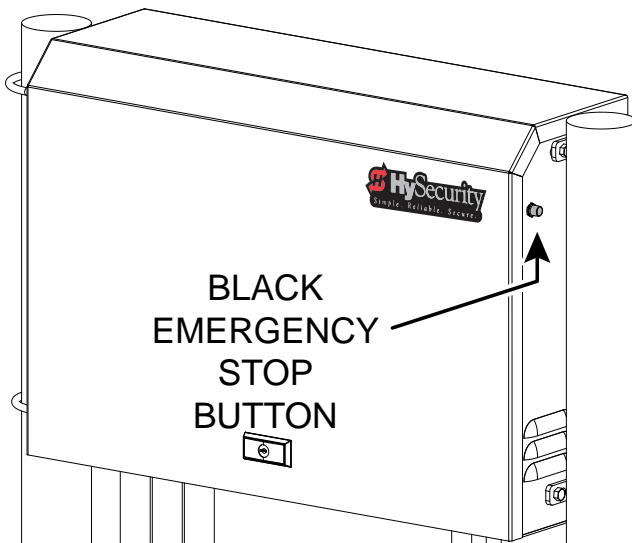

Figure 1. Black Emergency Stop Button

EMERGENCY RELEASE

Make sure and teach all users how to turn off electric power and how to move the gate manually. SlideSmart allows a gate to be pushed manually when the operator's DC power is turned off. (You **DO NOT** need to turn AC power off to manually push the gate.) See NOTICE.

When you turn DC power off, the following occurs:

- The motor disengages which makes it easier to push the gate open (or close)
- The GATE NO LOAD (FAULT 4) may appear on the display
- The position sensor is active and established limits are remembered

To turn DC power on, take the following steps:

1. Make sure the gate is not moving.
2. Flip the DC power switch on.
3. Clear any faults by pressing STOP or RESET.

NOTICE

If you turn OFF both power switches (AC and DC), the operator will search for the target to re-establish its limits. When you turn AC & DC power back ON, the operator will cycle the gate and search for the target magnet (its "home" position). An operator with the DC power switch ON and the AC power switch OFF still functions normally, but "NO AC" flashes in the display. If you "push" the gate, it will push back as the position sensor is active and the motor is engaged.

SITE OVERVIEW & PLANNING

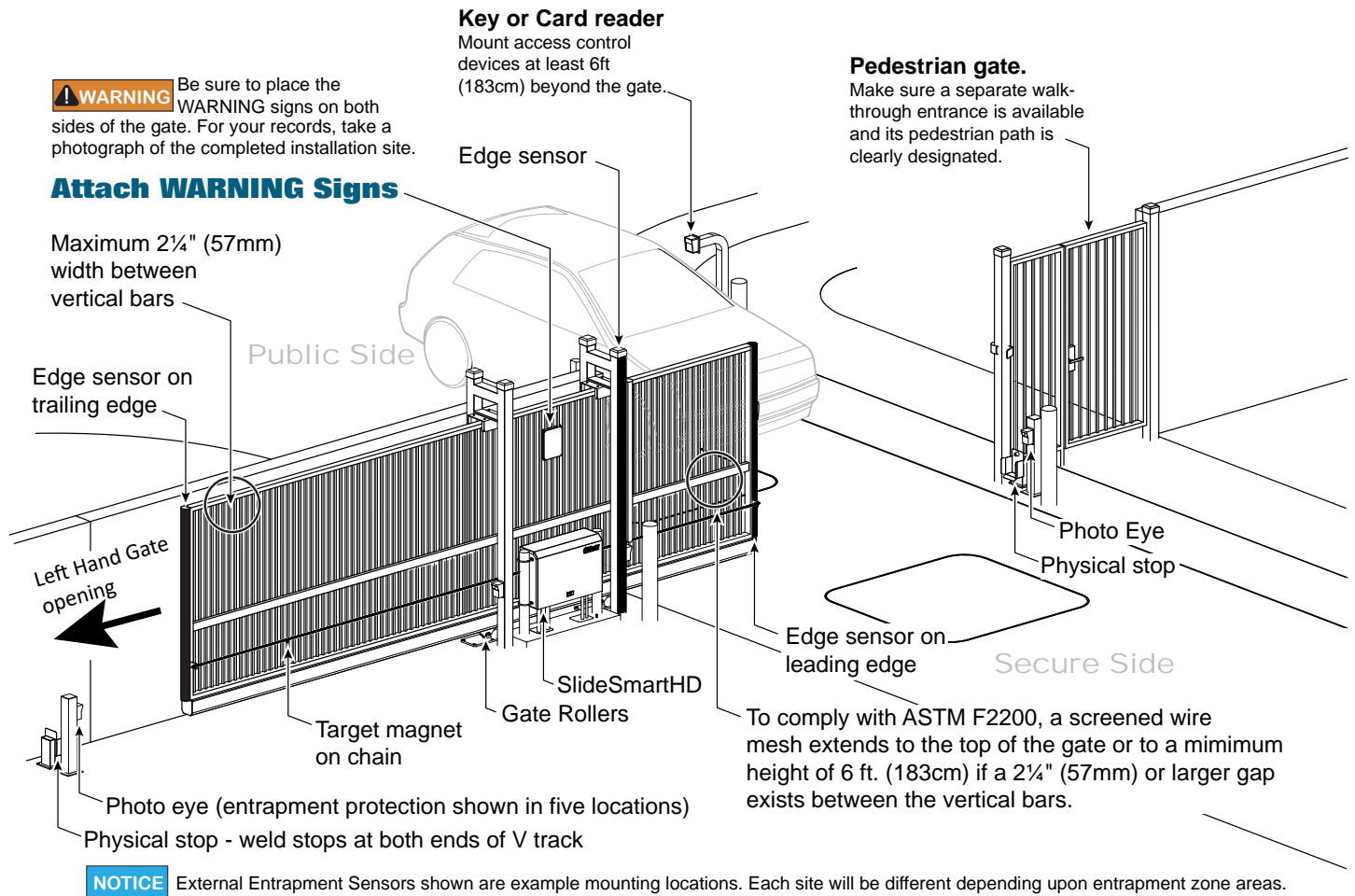

Figure 2. Site Overview and Planning

Table 1. SlideSmart Specifications

Operator	SlideSmartHD 15S	SlideSmartHD 25	SlideSmartHD 30
Duty Cycle	Continuous	Continuous	Continuous
Power, 1Ø	Switch Selectable 115 volts, 3 amps, 50/60 Hertz 208-230 volts, 1.5 amps, 50/60 Hertz	Switch Selectable 115 volts, 3 amps, 50/60 Hertz 208-230 volts, 1.5 amps, 50/60 Hertz	Switch Selectable 115 volts, 3 amps, 50/60 Hertz 208-230 volts, 1.5 amps, 50/60 Hertz
Motor	1 hp	1/2 hp	1 hp
Gate Speed	0.75, 1, 1.25, or 2.25 ft/s (23, 30, 38, 68.5 cm/s)	0.75, 1, or 1.25 ft/s (23, 30 or 38 cm/s)	0.75, 1, or 1.25 ft/s (23, 30 or 38 cm/s)
Gate Weight	Maximum 1,500 lbs (680.3 kg)	Maximum 2,500 lbs (1,134 kg)	Maximum 3000 lbs (1,361 kg)

PAD CONDITION

1. Follow the local building codes to identify the frost line and determine the required depth of the concrete pad. HySecurity recommends a minimum 16-inch depth with a minimum 2-inch extension. Refer to Figure 3.
2. Before pouring the pad, consider conduit placement so it fits within the confines of the 7 x 6-inch cutout in the SlideSmart base as shown in Figure 3. Run separate conduits for:
 - high voltage wiring (115/230V supply power) including equipment ground

- low voltage wiring (12V and 24V accessory power)
 - vehicle loop control wiring
 - primary/secondary connections
3. Extend conduit height 2-inches (5cm) above the pad (4-inches (9cm) above ground level). Make sure the concrete forms are square with the gate and the pad is level. The operator footprint, with covers, is approximately 30 x 10 inch rectangle. See Figure 3 for the minimum pad dimensions.

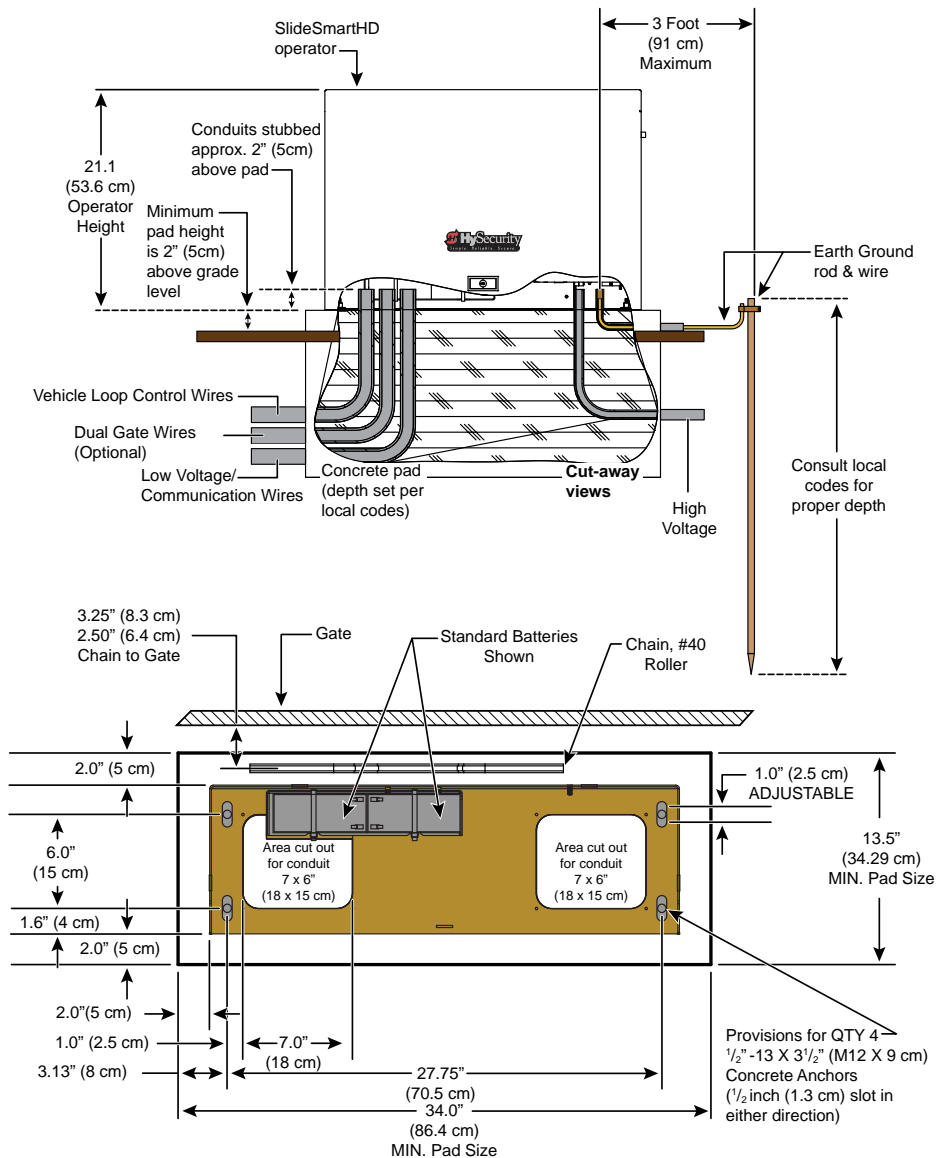

Figure 3. Conduit View

FRONT INSTALLATION

The most common and cost efficient type of installation is the front installation. See Figure 4 and Figure 5.

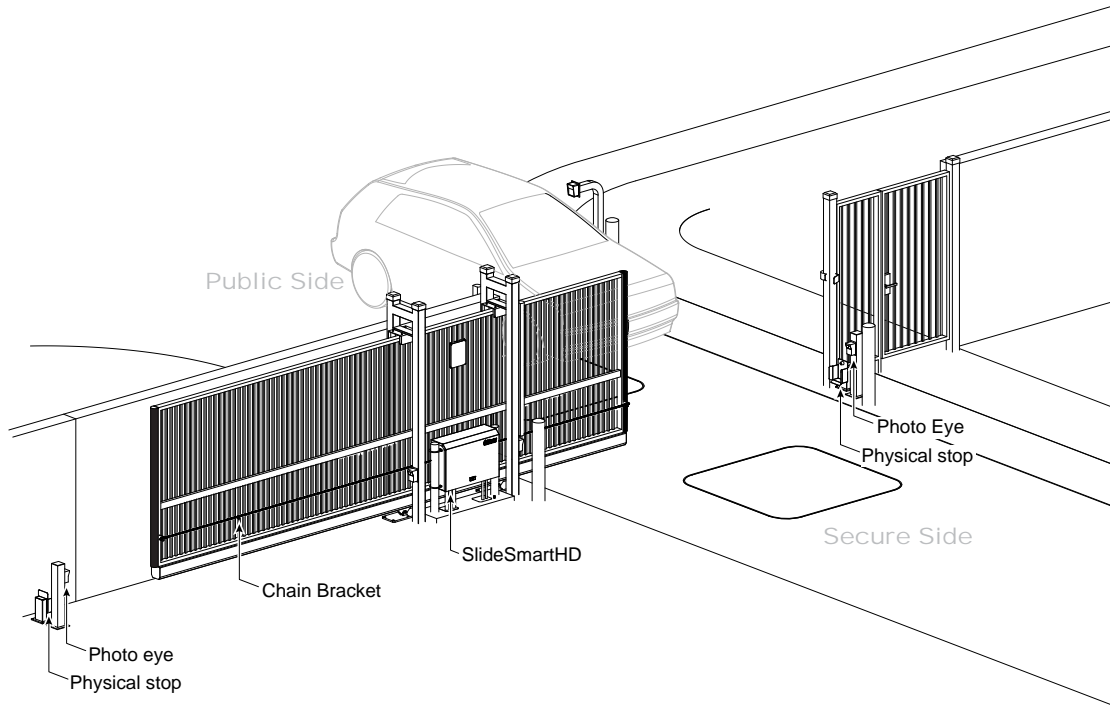

Figure 4. Front Installation

NOTICE

Several different ways to mount the SlideSmart operator exists. A few are shown here. For more detailed drawings, refer to "Appendix A - Installation Configurations" on page 111.

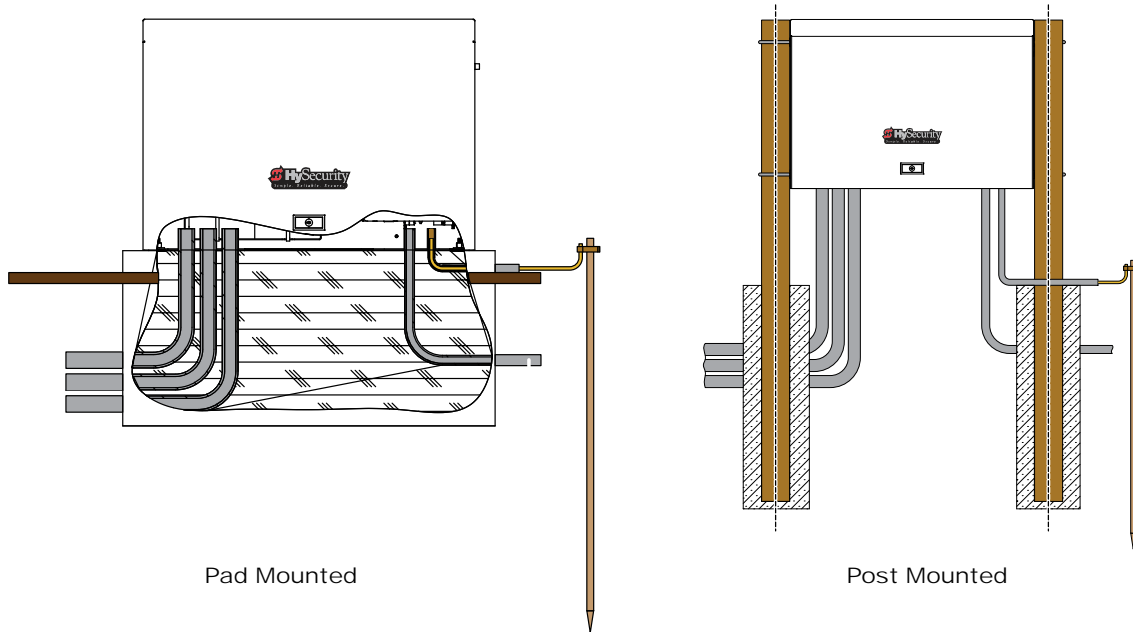

Figure 5. Pad and Post Mount

REAR INSTALLATION

A rear installation requires additional idler wheels and gate brackets, but it provides aesthetics as the chain is not visible along the gate. See Figure 6.

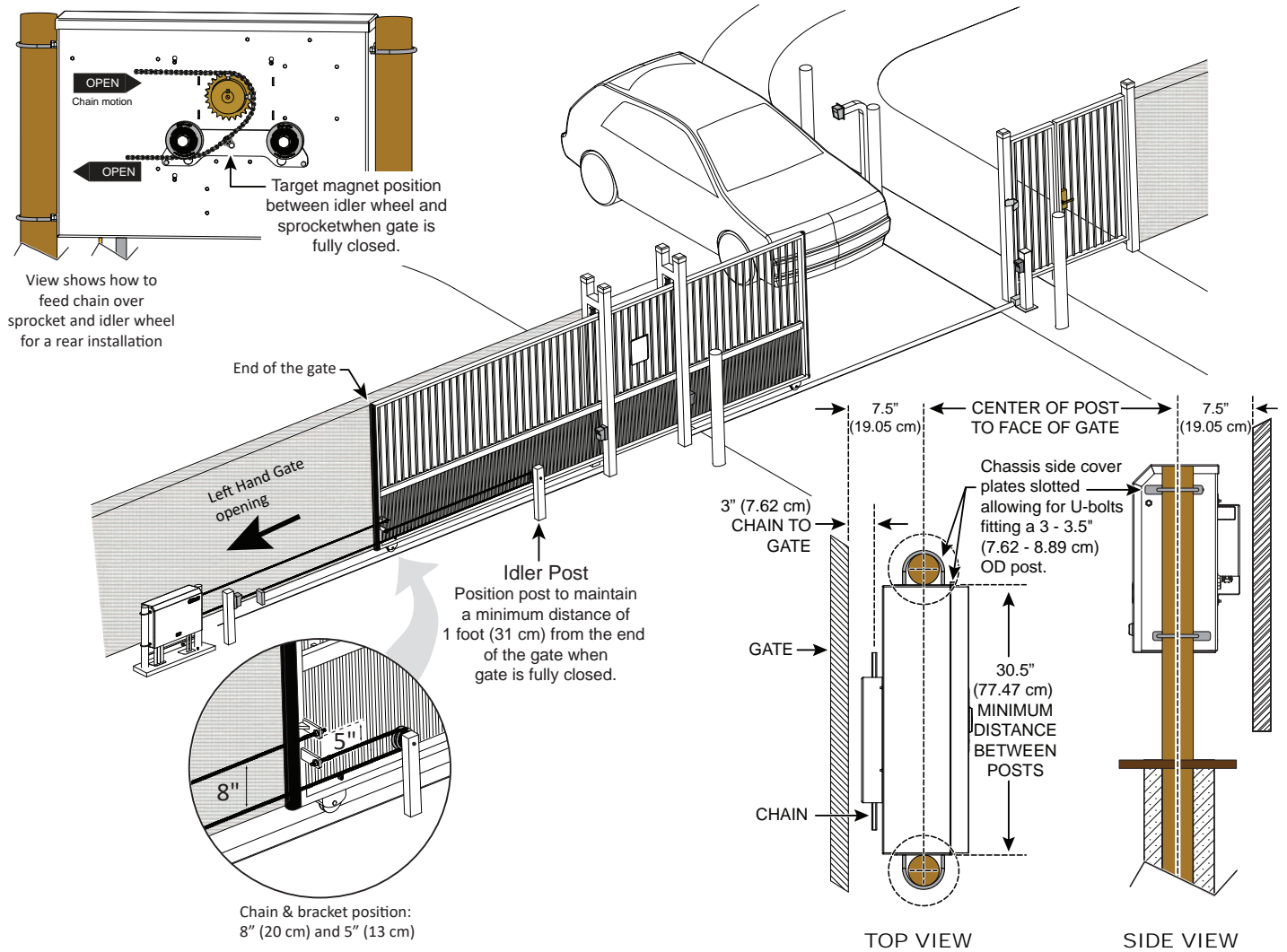

Figure 6. Rear Installation

UNPACKING THE OPERATOR

Prepare the gate operator for installation. See Figure 7.

1. Open the top of the box and remove packing materials.
2. Cut open the box to access the operator.
3. Unlock the keyed latch and lift the cover up and off the base of the operator. DO NOT lift the cover by its lock.

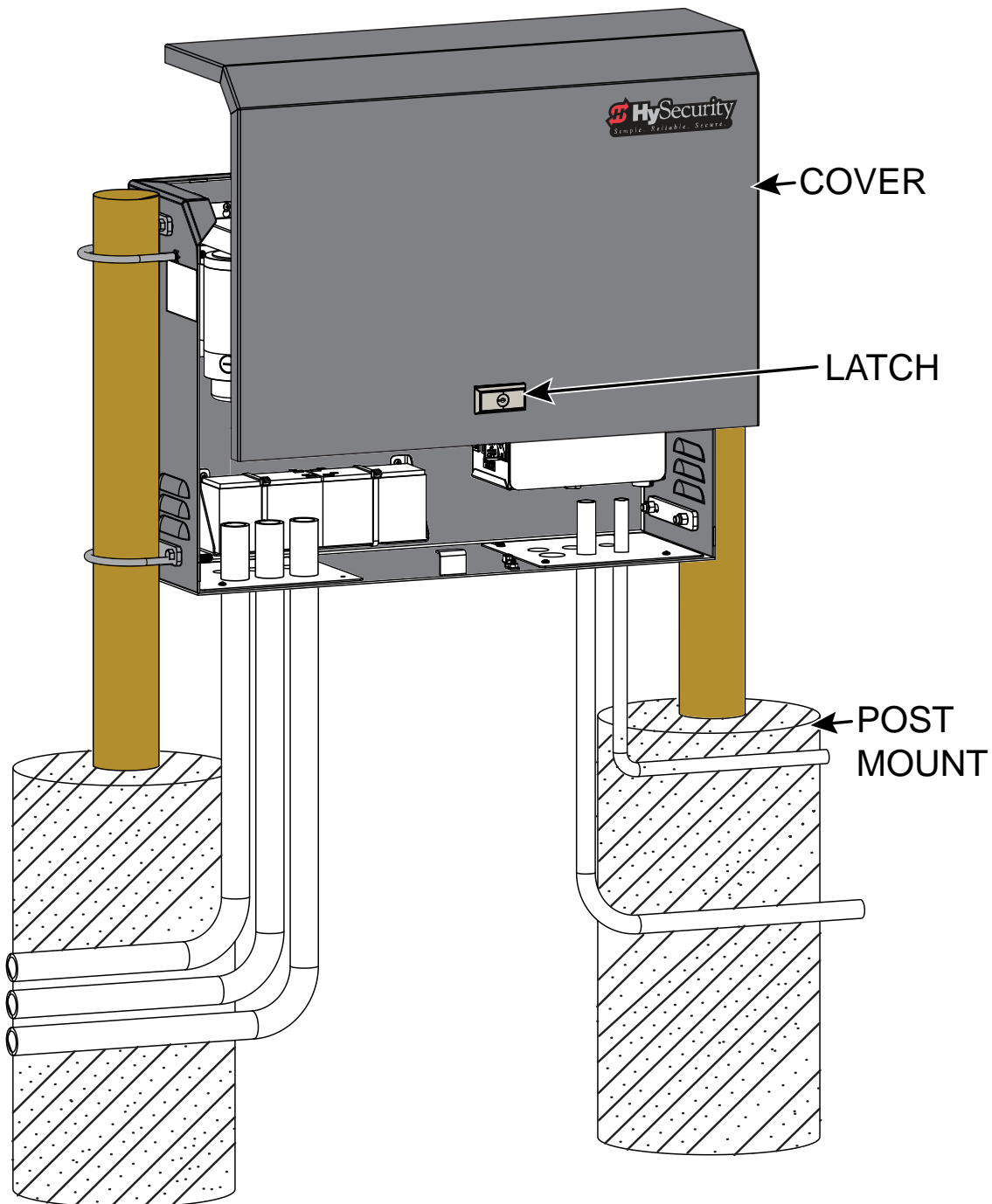

Figure 7. Unpacking the Operator

CONCRETE PAD MOUNT

Install the operator, by taking the following steps:

1. Place the operator on the concrete pad base to best suit the conduit area cut outs as shown in Figure 8 and Figure 9. Use the operator or the template provided on the packaging box as a template and center it on the pad. The chain path must be parallel with the gate.
2. Assess any limitations in the chain path (i.e. gate support posts). Adjust the operator's location as required. Mark the mounting locations based on gate, operator, and chain requirements. See Figure 8 and Figure 9.
3. Route conduits through concrete pad base and SlideSmart HD operator. See Figure 5 and Figure 8.
4. For additional types of mounting options, refer to the Appendix.

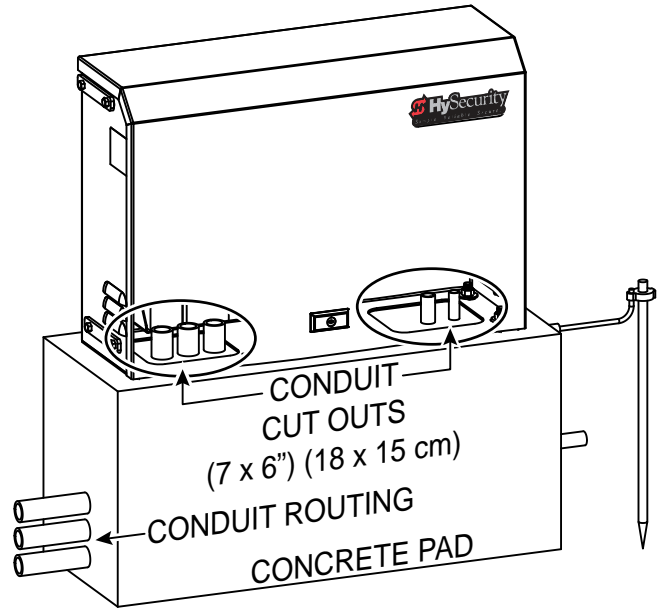

Figure 8. Pad Mounting

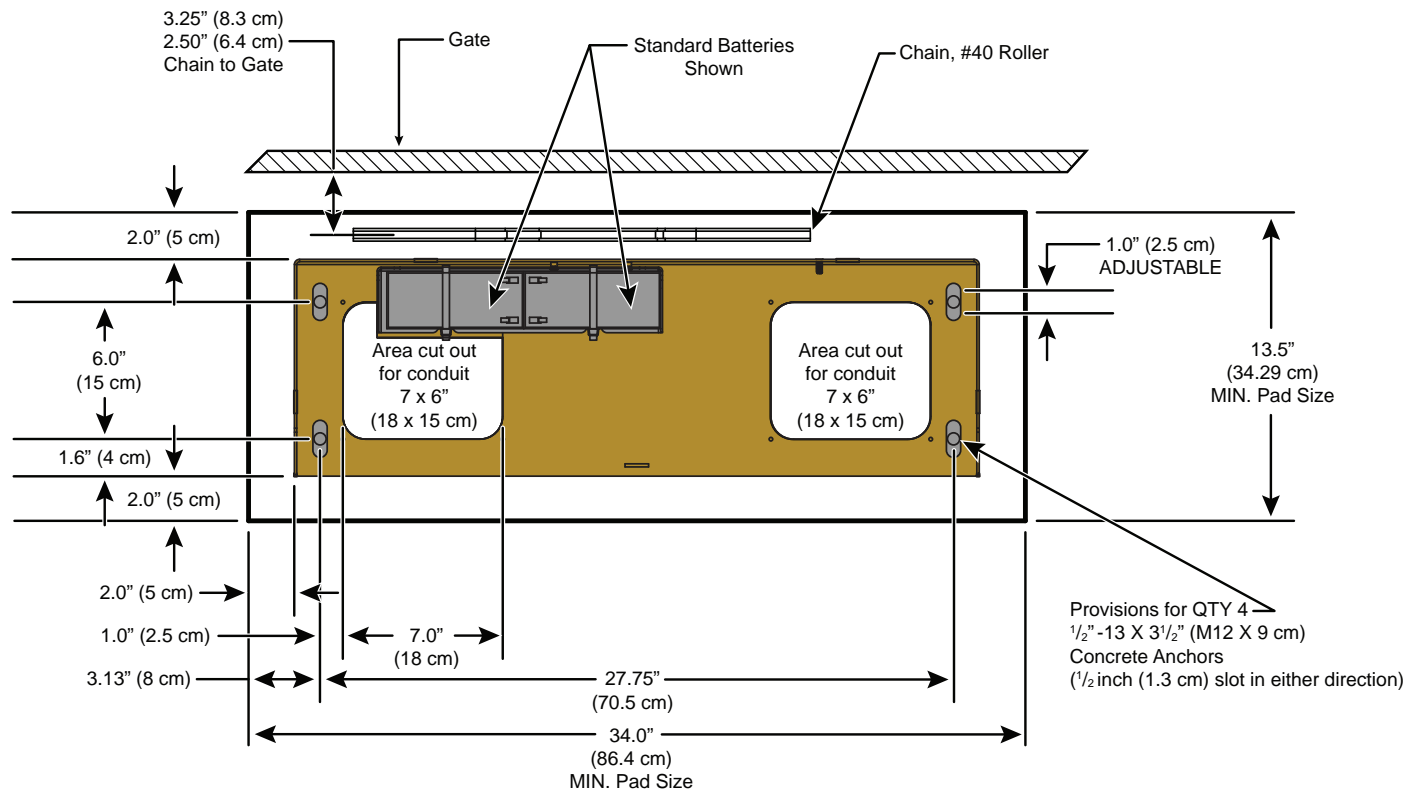

Figure 9. Concrete Pad Dimensions and Overhead Gate View

GATE BRACKET AND CHAIN INSTALLATION

1. Secure the gate to prevent movement.
2. Measure for proper chain alignment BEFORE welding the brackets to the gate. Make sure the chain will run horizontal to the ground and parallel with the gate.
3. Weld the chain bracket in two places: leading edge and trailing edge. You may need to cut the length of the bracket to achieve proper chain alignment.
4. Attach the eye bolts to the brackets, and then attach the connector link between the chain and eye bolt.
5. Feed the chain around the idler wheels and over the sprocket (See Figure 11) and attach the chain to the bracket on the opposite end of the gate. Make sure the chain is horizontal to the ground and parallel to the gate.
6. Adjust the nuts on the eye bolt to tighten the chain (minimize sag, but avoid overtightening). Chain sag should be about 1/4 – 3/8 inches per foot over travel length.

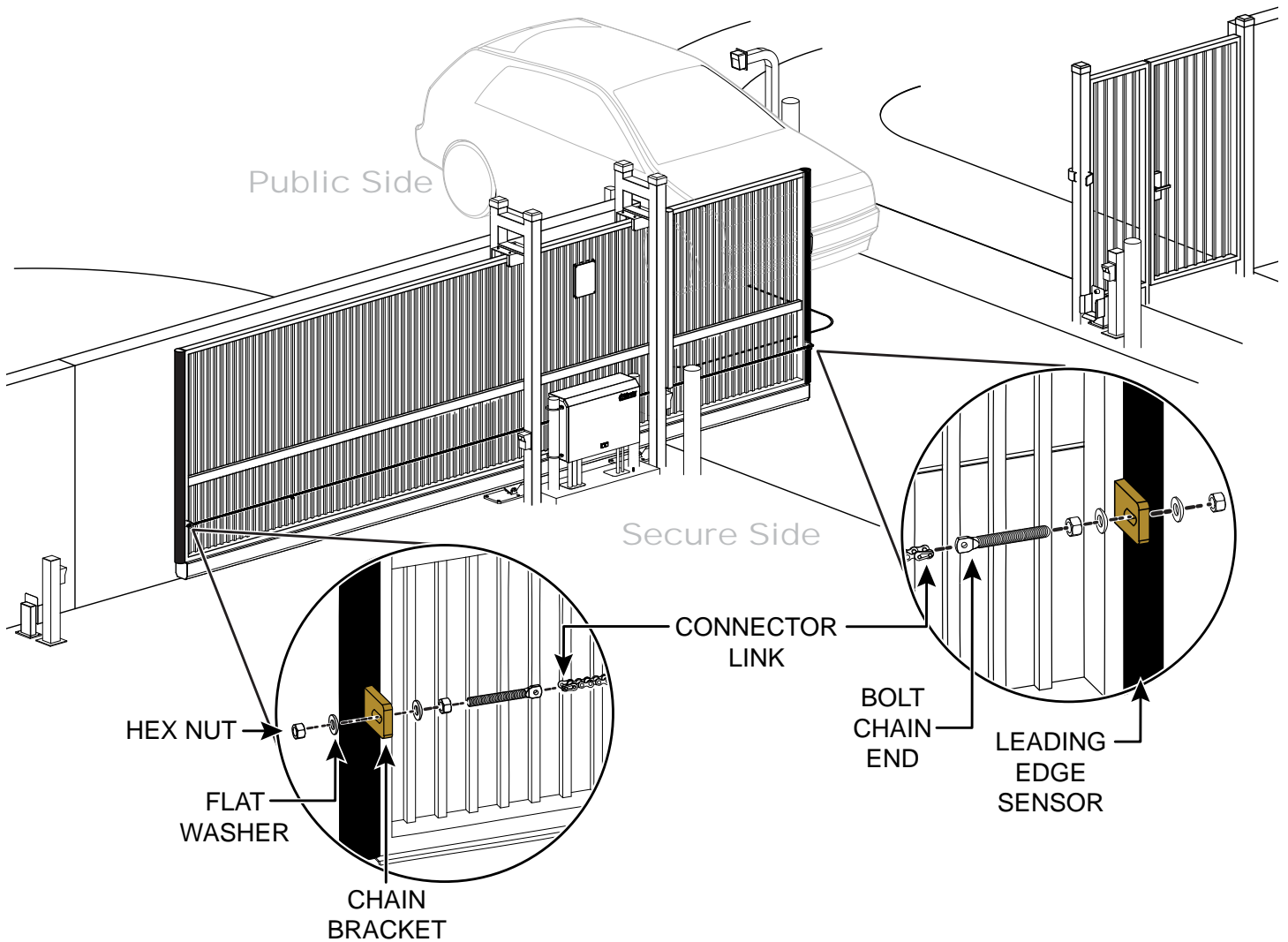

Figure 10. Gate Bracket and Chain Installation

ALIGNING THE CHAIN

1. For a front installation, feed the chain over the sprocket and beneath the idler wheels. See Figure 11.
2. For a rear installation, see Figure 6.
3. In either situation, make sure the chain is properly aligned horizontal to the ground and parallel to the gate.

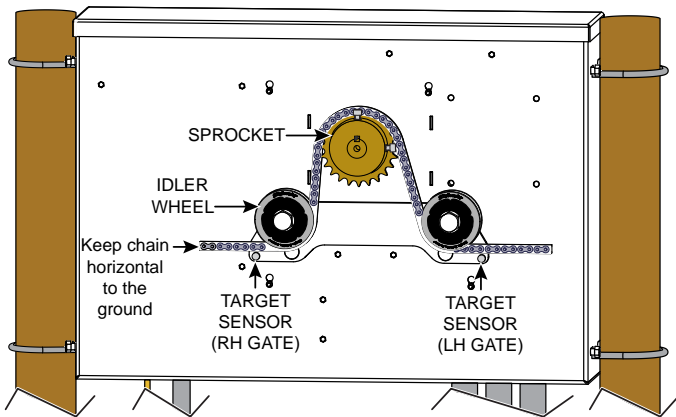

Figure 11. Rear View Chain Installation - Front View

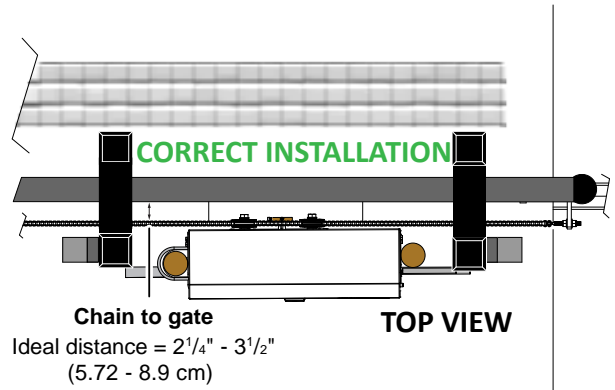

Figure 12. Correct Rear View Chain Installation

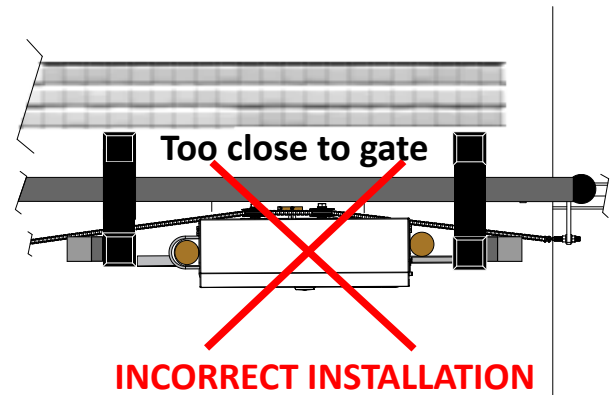

Figure 13. Incorrect Rear View Chain Installation

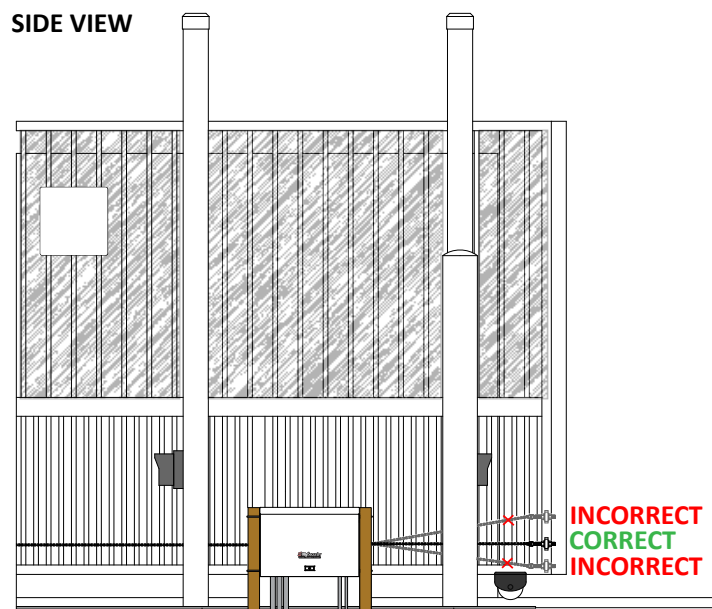

Figure 14. Side View Chain Installation

CONNECTING THE BATTERY AND TURNING DC POWER ON

1. Connect the red battery wire to its spade terminal. Figure 15.
2. Turn DC power ON. The USAGE CLASS appears the first time power is supplied to the operator.
3. To navigate within the Setup Menu, use the SELECT, NEXT, and PREV buttons as shown in Table 2.

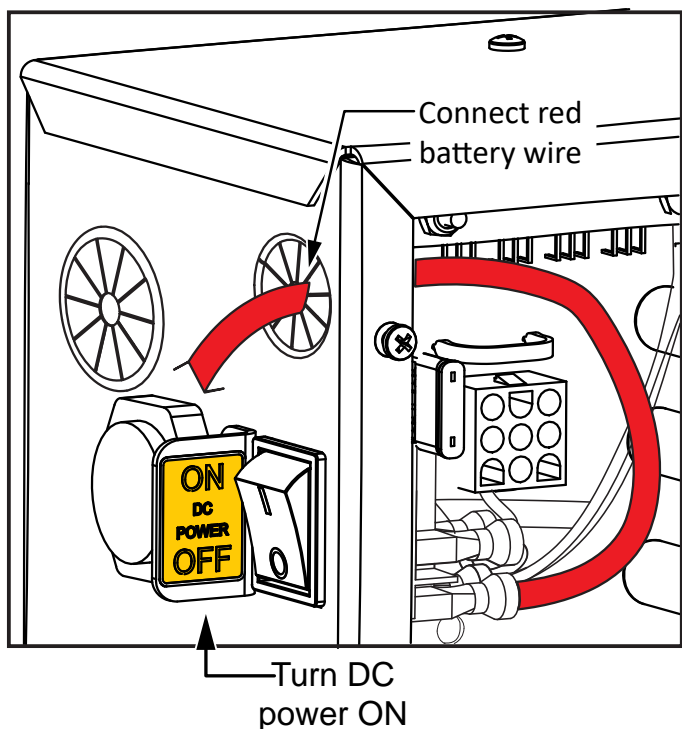

Figure 15. Connect Battery and Power On

PROGRAMMING THE INITIAL SETUP MENU

Several sequential displays present information which must be configured before SlideSmart will function. Once the configuration is complete, the information is retained even when a power loss occurs.

NOTICE

Programming the Setup Menu is usually a one-time occurrence unless factory defaults are reinstated through the Installer Menu. The RESET and MENU buttons do not function during the initial configuration of the Setup Menu.

Table 2. Menu Mode Navigational Buttons

To edit the Menu	To navigate through the SELECTIONS	To choose what is on the display	To navigate between menus
Press SELECT. Two top characters blink.	Press NEXT. Continue pressing NEXT to view all selections.	Press SELECT. blinking characters become static.	Press NEXT or PREV. Advance - press NEXT. Previous - press PREV.

Table 3. Programming Initial Setup Menu

Display	Display Selections
<div style="border: 2px solid black; padding: 5px; width: fit-content; margin: auto;"> UC 0 USAGE CLASS </div>	SELECTIONS 0 - No Usage Class set. 1 - Single Family residential up to four units. 2 - Multi-family, hotel, etc. 3 - Industrial use, not for general public. 4 - Guarded and monitored facility, not for general public.
<div style="border: 2px solid black; padding: 5px; width: fit-content; margin: auto;"> SH 0 GATE HANDING </div>	SELECTIONS 0 - No handing set. Gate will not move until handing is set. Looking at the gate from the secure side, choose: L - If the gate slides open to the left. R - If the gate slides open to the right.
<div style="border: 2px solid black; padding: 5px; width: fit-content; margin: auto;"> WT 0 GATE WEIGHT (LB) </div>	SELECTIONS 0 - Gate weight not set. SlideSmart DC HD25 and HD30 1 - Gate weight: 0 – 700lbs (0 – 318Kg) 2 - Gate weight: 701 – 1400lbs (318 – 635Kg) 3 - Gate weight: 1401 – 2100lbs (635 – 953Kg) 4 - Gate weight: Over 2100lbs (over 953Kg) Once gate weight is set, program Sensor1, Sensor2, Sensor3.
<div style="border: 2px solid black; padding: 5px; width: fit-content; margin: auto;"> S1 0 SENSOR #1 TYPE </div>	0 - disabled 1 - (NOT USED) 2 - (EYE CLOSE) 3 - (EDGE CLOSE) 4 - (EYE OPEN) 5 - (EDGE OPEN) 6 - (EDGE BOTH) (Swing Gates only) 7 - (EYE BOTH) (solo Slide Gates only)
<div style="border: 2px solid black; padding: 5px; width: fit-content; margin: auto;"> S2 0 SENSOR #2 TYPE </div>	Same as Sensor 1
<div style="border: 2px solid black; padding: 5px; width: fit-content; margin: auto;"> S3 0 SENSOR #3 TYPE </div>	Same as Sensor 1

ESTABLISHING THE OPEN & CLOSE LIMITS

After programming the initial setup menu, the operator needs to establish the OPEN and CLOSE limits.

The LEARN LIMITS display automatically appears after you set the gate weight. To set the open and close limits, take the following steps and see Figure 17:

1. Hold the OPEN button until the gate slides to full open. Release the OPEN button. Note that if you go too far, you can press CLOSE to reverse direction. Press STOP twice to store the open stop location in memory.

NOTICE

Do not set limits at the physical OPEN and CLOSE stops. Leave a 1 to 2-inch (2.5 - 5cm) gap to allow some slack and give in the chain. This will help prevent chain wear and avoid stress on gate hardware.

2. Hold the CLOSE button until the gate slides to full close. Release the CLOSE button and press STOP twice. The full close stop is retained in memory.

NOTICE

Pressing OPEN will reverse direction.

3. GATE CLOSED appears on the display and ALERT 15 flashes until the target magnet is installed and its location stored in memory. See "Installing the Target Magnet" on page 26.

NOTICE

NO AC POWER flashes after the gate status display if the AC power has not been connected or the lower power switch is turned off.

Once the target is installed, SlideSmart never forgets its limits. AC or DC power can be lost and SlideSmart always remembers where to stop the gate within a ¼-inch of its established limit. The only exception occurs when a chain is replaced or damage occurs to the operator itself. To reset limits, see "Resetting the OPEN and CLOSE Limits" on page 48.

CAUTION

Do not install the target magnet before setting the OPEN and CLOSE limits. If the target magnet is installed before setting the limits, the target magnet can get wound around the roller sprocket which may damage the SlideSmart operator and void the Limited Warranty.

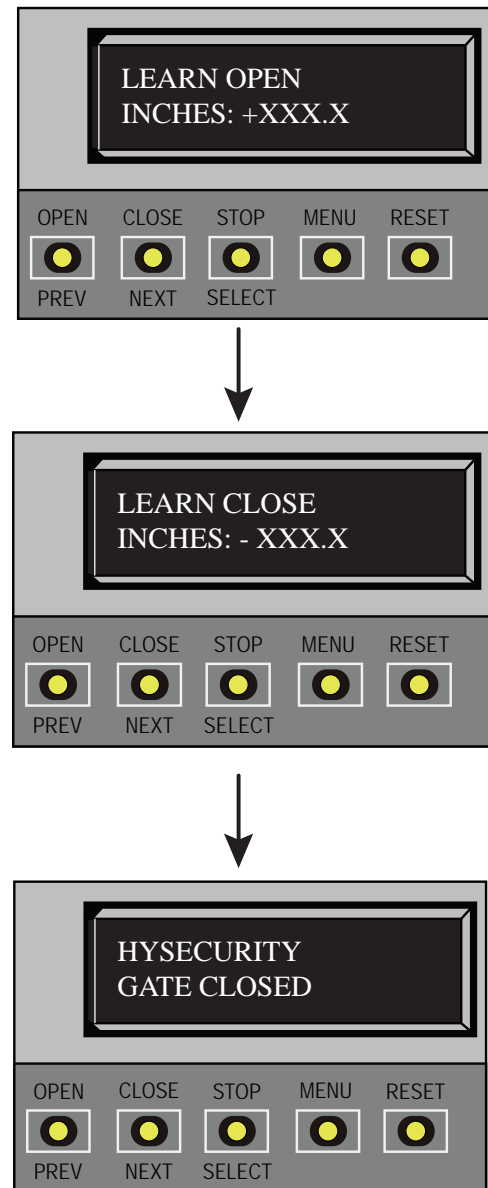

Figure 16. Programming Limits

INSTALLING THE TARGET MAGNET

1. With gate CLOSED, mark chain link directly in front of target sensor. See Figure 17.

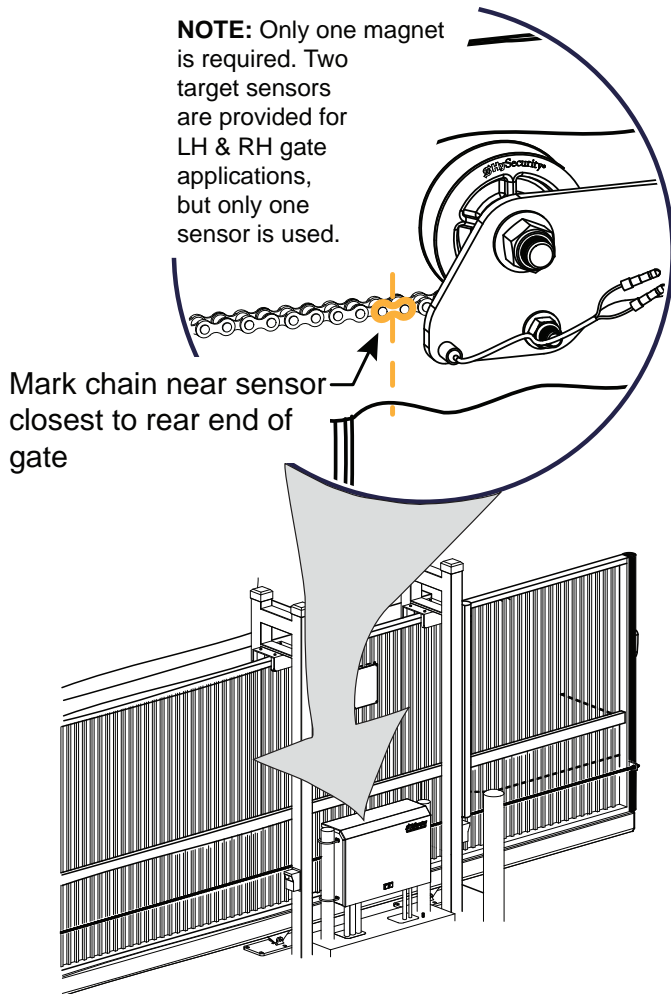

Figure 17. Marking Chain Link for Target Sensor

2. Press the OPEN button to move the gate a few feet and then press STOP.
3. Find the mark on the chain link and count about 4 fixed links toward the operator (approximately 3 inches, 76mm).
4. Remove the screw from the Target Magnet.
5. Fasten the target magnet to the chain link as shown in Figure 18. Make sure the large white centerpiece is facing toward the operator. Insert the screw and tighten it securely.

CAUTION

To avoid damage to the idler wheel, the head of the screw must be flush with the chain rollers.

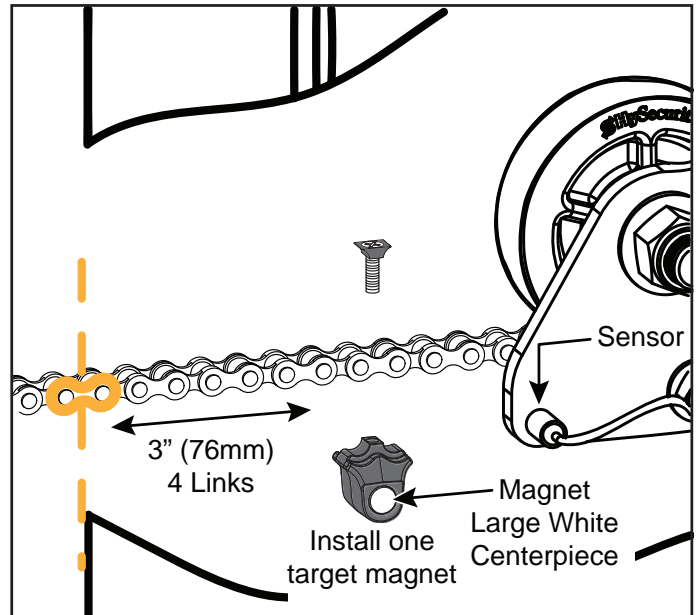

Figure 18. Installing Target Magnet

6. Press OPEN and wait for the gate to travel and stop at its full open position.
7. Press CLOSE. As the gate approaches the full close position, the target magnet passes the target sensor and an audible beep is heard. Read the NOTE below, and then proceed to step 8 to verify that the operator has learned its limits.

NOTICE

If "ALERT 15 - NO TARGET" appears on the display after the target magnet has been installed and a full gate cycle completed (steps 6 & 7), it means that the target magnet has not been detected by the operator. Check chain alignment and make sure the target magnet is positioned properly and passes across the face of the sensor. See Figure 18. Repeat steps 6 and 7.

8. To verify that the operator recognizes the target magnet, turn off both DC and AC power switches and watch the display go blank. Then, turn both switches on. The operator beeps indicating Limit Relearn Mode. The gate then travels about 6 inches (15cm) in the open direction and stops. The buzzer beeps again and the gate travels in the close direction at a rate of 1/2 ft/s until the target magnet passes the target sensor. The buzzer sounds one last time, the operator resets, and "GATE CLOSED" appears on the display.
9. If "LEARN OPEN" appears, then the target magnet was not detected. Check chain alignment and make sure the target magnet passes across the face of the sensor. See Figure 18. Repeat steps 6 - 8. If you are still having difficulty with the operator learning its limits, re-install the target magnet. See "Establishing the Open & Close Limits" on page 25.

FRONT INSTALLATION

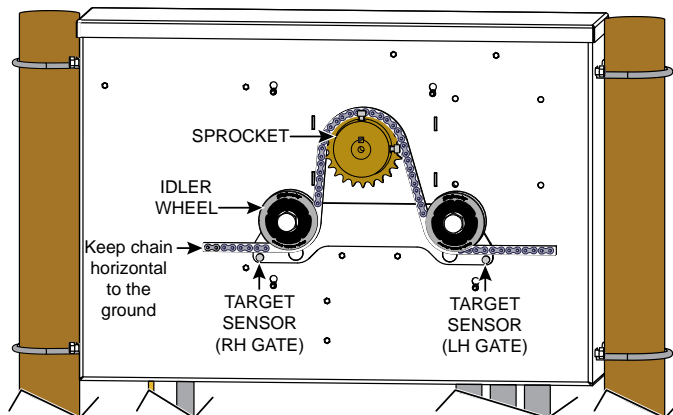

Figure 19. Target Magnet Installation Front

⚠ CAUTION

When the gate is CLOSED, the target magnet should stop between the idler wheel and the roller chain sprocket. The target magnet **MUST NOT** enter the sprocket teeth. See Figure 19.

REAR INSTALLATION

Location of target on a rear installation with the gate in full CLOSE position.

See Figure 20 to view a rear installation for a left hand gate.

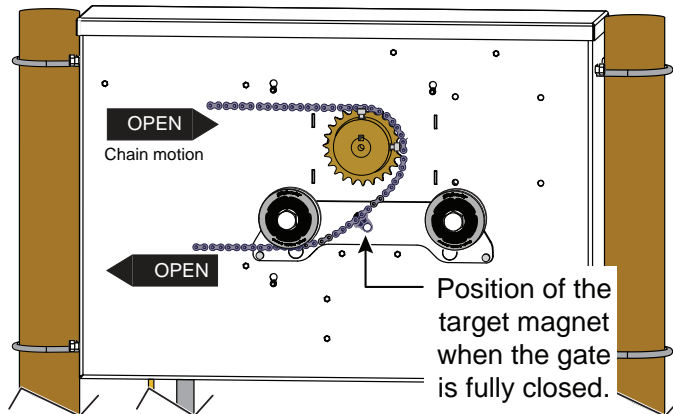

Figure 20. Target Magnet Installation Rear

INSTALLING THE EARTH GROUND

An earth ground refers to the grounding rod and accompanying equipment ground which need to be installed to safeguard against potential electrical shock and damage to personnel and equipment.

! DANGER

The potential for lightning discharge exists with all gates, fences and gate operators. National Electric Code (NEC) requires a separate earth ground in addition to the required equipment ground.

HySecurity recommends grounding the operator with a separate earth ground rod to shield the operator against electromagnetism and other electrical signals that may cause erratic operation with or damage to the Smart DC Controller.

NOTICE

If you do not ground the operator with a separate earth ground rod, you risk voiding the Limited Warranty.

For earth grounding requirements, refer to the National Fire Protection Association (NFPA) 780 - *Standard for the Installation of Lightning Protection Systems*. Highlights of the standard include.

- The ground rod is a solid copper rod: minimum requirements: $\frac{5}{8}$ inch (16mm) diameter and 10 feet (3m) in length.
- The ground rod is driven into the earth (refer to local codes for proper depth requirements).
- The ground rod is electrically bonded to the chassis with a single length of un-spliced 6 AWG copper wire less than 3 feet (91cm) long.
- Local jurisdictions may impose additional requirements above the NEC and NFPA 780. Consult the local codes and regulations regarding requirements in your area.

Take the following steps to comply with NEC and NFPA 780 standards:

1. Install a grounding rod per local building codes. See Figure 21.
2. Attach a large earth ground wire (6 AWG) from the grounding rod to the lug nut on the base of the chassis.
 - *New site:* Run the 6 AWG wire through the concrete base and into the cutout on the chassis base.
 - *Existing site:* Run the 6 AWG wire beneath the chassis.

Properly grounding the gate operator is critical to gate operator performance and the life of its electrical components. Use sufficient wire size during installation. Refer to "Wiring 115VAC Power" on page 30 or "Wiring 208/230VAC Power" on page 31.

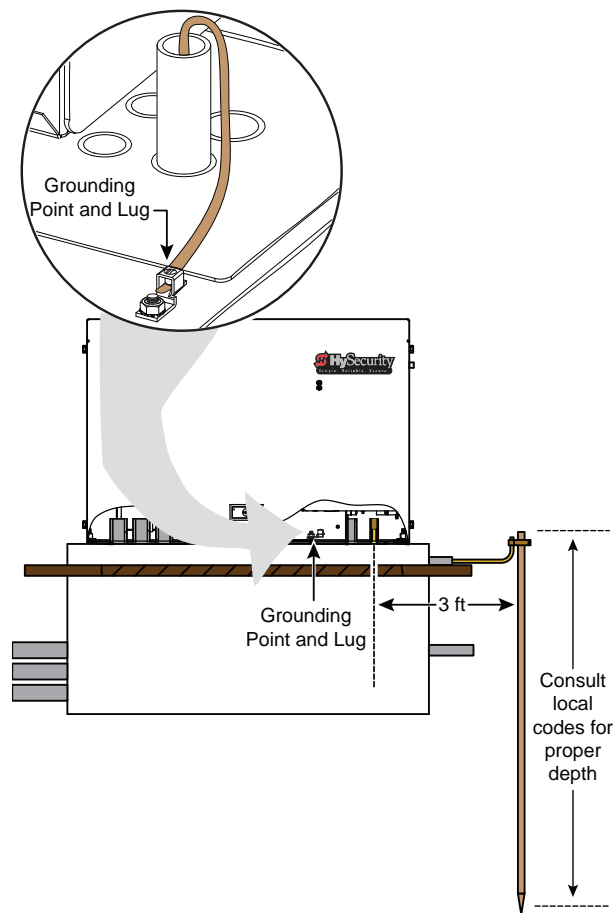

Figure 21. Install Earth Ground

WIRING AC POWER

⚠ DANGER

Turn off AC power at the source (circuit breaker panel) before accessing the wires in the SlideSmart junction box. Follow facility Lock Out/Tag Out procedures. Make sure both the DC and AC power switches, on the side of the SlideSmart control box are in the off position. See Figure 22.

⚠ CAUTION

Wiring of gate operators must conform to the NEC standards and comply with all local codes. If you plan to connect to 208/230VAC power, read the WARNING in Figure 2-2. The voltage selector switch on the AC Power board must be moved to the 230V position or damage to the operator will occur and void the Limited Warranty.

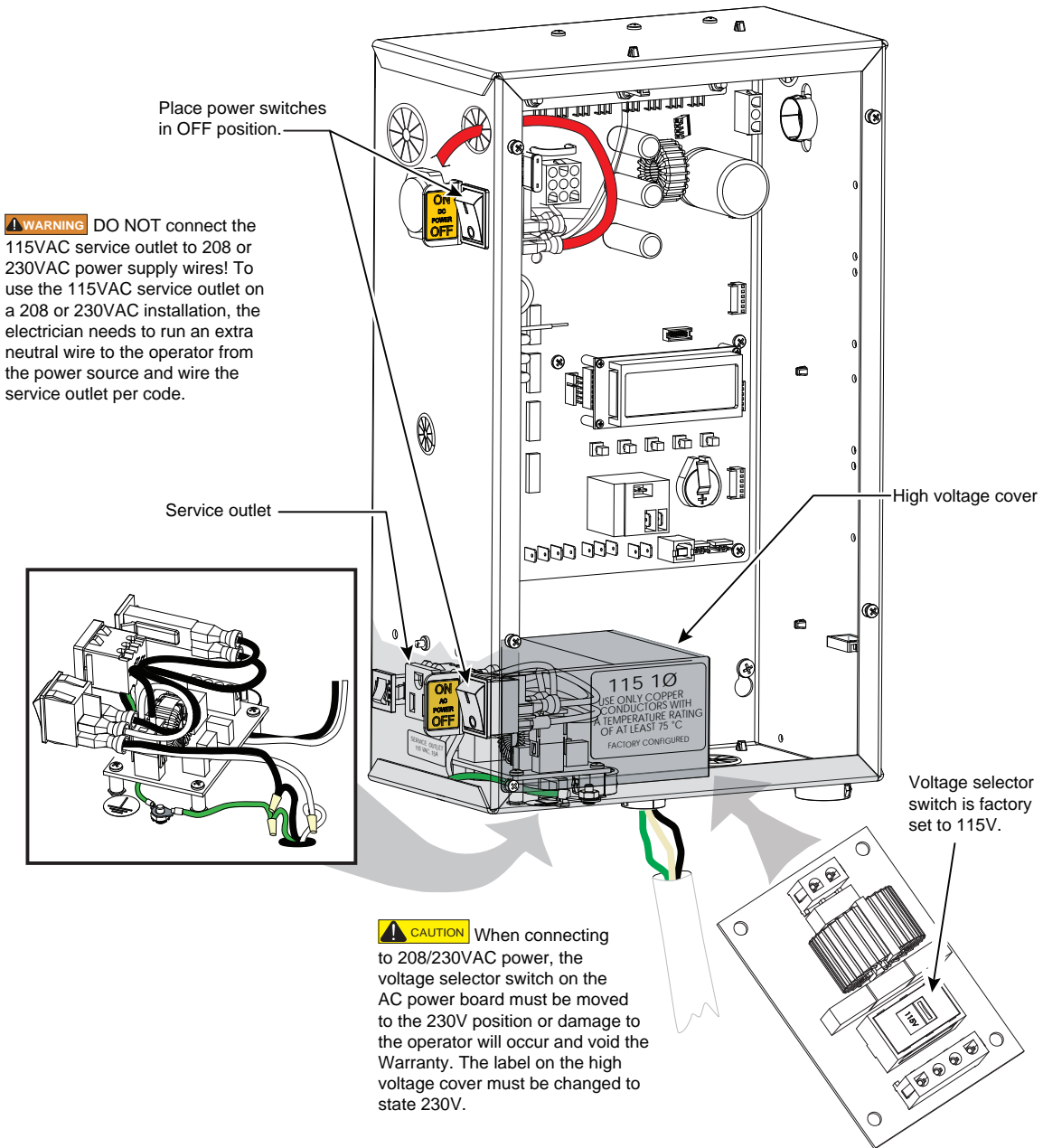

Figure 22. Wiring AC Power

WIRING 115VAC POWER

For standard 115VAC power connection:

- Verify AC power supply wires and low voltage (12V & 24V accessory power wires) run through two separate conduits. The higher voltage from the AC power supply may cause interference and anomalies in SlideSmart operation if the high and low voltage wires are routed through the same conduit.
- Maximum gate operator current draw is 3 Amps on a dedicated 115VAC circuit (20A dedicated circuit is recommended).
- Make sure proper wire size is used. Use Table 4 as reference for maximum allowable wire run from the power source to the operator for various wire sizes.

Table 4. Wire Gauge versus Run

AC Power	14 ga. wire	12 ga. wire	10 ga. wire
One operator 115V	730 ft (223 m)	1200 ft (366 m)	1900 ft (579 m)
Two operators 115V	460 ft (140 m)	750 ft (228 m)	1160 ft (354 m)

NOTICE

Table 4 assumes a dedicated circuit with an accessory power load up to 2A. Additional loads require that the wire size be increased or the distance of the run be decreased.

To connect to 115VAC power, take the following steps:

1. Ensure AC power is turned off at its source and the DC and AC power switches on the operator are in the off position.
2. Access the input power wires and service outlet wires by removing the two Phillips-head screws that secure the high voltage junction box cover. See Figure 22.

NOTICE

The service outlet wires are solid copper and are labeled and bound together to keep them separate from the AC power switch wires.

3. Wire nut or crimp bond the power supply wires to the black and white lead wires coming from the AC power switch (no label). See Figure 22.
4. Wire nut or crimp bond the equipment ground wire to the green ground wire in the junction box.
5. To activate the 115VAC service outlet, include the black and white outlet lead wires and the green ground wire in the connections made above.
6. Neatly organize all wire connections and replace the high voltage junction box cover. Secure it with the two Phillips-head screws.

WIRING 208/230VAC POWER

CAUTION
 All SlideSmart operators are shipped from the factory as 115VAC units. When connecting to 208/230VAC power, the voltage selector switch on the AC power board must be moved to the 230V position or damage to the operator will occur and void the Limited Warranty.

For the 208/230VAC power connection:

- Verify AC power supply wires and low voltage (12V & 24V accessory power wires) run through two separate conduits as discussed in "Wiring 115VAC Power" on page 30.
- Maximum gate operator current draw is 1.5 Amps on a dedicated 208/230VAC circuit (20A dedicated circuit is recommended).
- Make sure proper wire size is used. Refer to Table 5.

Table 5. 208/230VAC Wire Gauge versus Run			
AC Power	14 ga. wire	12 ga. wire	10 ga. wire
One operator 230V	2095 ft (639 m)	3350 ft (1021 m)	5300 ft (1615 m)
Two operators 230V	1465 ft (446 m)	2350 ft (716 m)	3750 ft (1143 m)

NOTICE
 Table 5 assumes a dedicated circuit with an accessory power load up to 2A. Additional loads require that the wire size be increased or the distance of the run be decreased.

To connect to 208/230VAC power, take the following steps:

1. Make sure the AC power is turned off at its source and the DC and AC power switches on the operator are in the off position.
2. Remove the high voltage protection cover by unscrewing the two Phillips-head screws that secure it. See Figure 22.

3. Toggle the voltage selector switch from 115V to 230V. Replace the high voltage cover and secure it. See Figure 23.

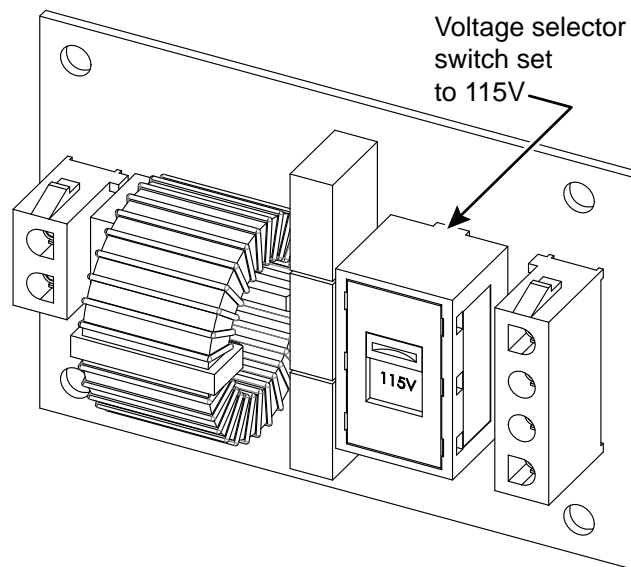

Figure 23. 208/230VAC Voltage Selector Switch

4. Access the input power wires by removing the two Phillips-head screws that secure the high voltage junction box cover. See Figure 22.
5. Wire nut or crimp bond the power supply wires to the black and white lead wires coming from the AC power switch (no label).
6. Wire nut or crimp bond the equipment ground wire to the green ground wire in the junction box.

DANGER
 Do not connect the 115VAC service outlet to 208/230VAC power supply wires. To use the service outlet with 208/230VAC supply power, a separate neutral wire (white) must be run from the power source. Follow guidelines according to the National Electrical Code Article 250.

7. Neatly organize all wire connections and secure the high voltage junction box cover with the two Phillips-head screws.
8. Place the 230V 1Ø label on the high voltage junction box cover over the 115V 1Ø label.

IMPORTANT CONSIDERATIONS FOR DC-POWERED OPERATORS

- Since the operator is intended to run on batteries, control of the load is important. Gates that move easily and do not bind will drain less energy from the battery, preserving capacity for more cycles during a power failure.
- Be certain to observe polarity when connecting the batteries or adding accessories. Reversed polarity may result in a non-functional operator or damage to a component. Red (+) is positive and black (-) is negative. If shorted, the batteries will generate a very high current. The batteries are connected in a series circuit: Join the positive (+) terminal from one battery to the negative (-) terminal of the next battery.
- Batteries have a finite life and age more quickly when exposed to temperatures above 80°F (27°C). Battery temperatures above 104°F (40°C) are damaging and significantly shorten battery life.
- As the batteries age, they will progressively lose their capacity to store energy. If the total amount of back up capacity is critical, plan to replace the batteries after two years of use especially in hot climates. Properly discard used batteries. Refer to Hazardous Materials and Proper Disposal on page 12

⚠ WARNING

Batteries contain sulfuric acid. Acid in your eyes, on your skin, or on your clothing can cause injury and severe burns. If batteries are dropped or damaged dispose of them properly.

- Batteries are rated to perform to capacity at certain temperatures. Variations in temperature affect performance of the batteries. An example of amp hour performance is shown in Table 6. HySecurity mounts the battery pack near the transformer to provide residual heat around the batteries which guards against amp hour loss.

Table 6. Amp Hour - Example of Battery Performance

Temperature	Capacity (%)
77°F (25°C)	100
32°F (0°C)	80
-22°F (-27°C)	50

- HySecurity uses a permanently sealed AGM-type battery which last much longer than wet cell batteries and needs no maintenance over its life span. Batteries are protected from over discharge by a low voltage sensing circuit. The charger circuit regulates to allow high charger output when the battery is partially discharged. The charger circuit automatically reduces the output to near zero as the batteries become fully charged.

NOTICE

The SlideSmart operator stores all User and Installer Menu settings in non-volatile memory (EEPROM). Configurations are saved if a power loss occurs, and reinstated once power is restored.

INSTALLING THE 50AH BATTERIES

HySecurity offers an extended DC power back up option with two 50Ah batteries.

1. Turn off DC and AC power switches.
2. To access the 8Ah batteries and disconnect its wires, cut the two black wire ties and slide the 8Ah batteries through the access window. See Figure 24.

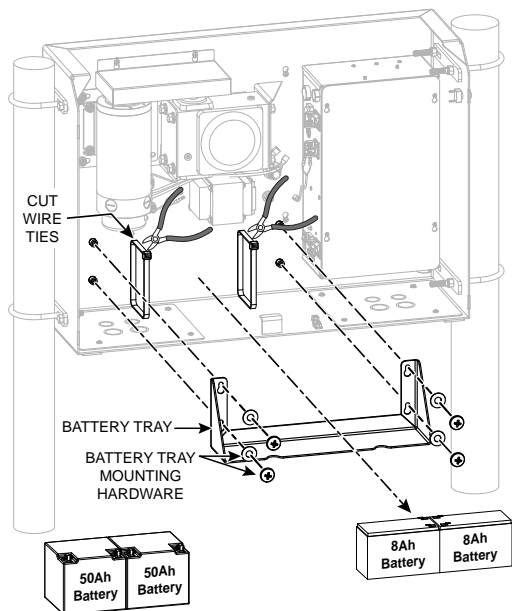

Figure 24. 8Ah Battery Removal

! DANGER

Make sure both the left and right 8Ah DC battery wires are disconnected. Never mix battery sizes, types, or brands. HySecurity strongly recommends that only sealed AGM style batteries be used. If you plan to remove the batteries from the operator, properly store or discard them. Refer to Hazardous Materials and Proper Disposal on page 12.

3. Place the two 50Ah batteries on the chassis. See Figure 25.
4. Attach the blue wire from the red terminal on one 50Ah battery to the black terminal on other 50Ah battery. See Figure 25.
5. Run the red and black wires (disconnected from the 8Ah batteries) through the hole in the control box. See Figure 25.
6. Using the wires supplied in the 50Ah battery kit, attach the red wire to the red positive terminal on the 50Ah battery. Connect its opposite end to the control box DC power switch. See Figure 25.
7. Connect the black wire to the black negative terminal on the 50Ah battery. Connect its opposite end to the control box DC power switch. See Figure 25.

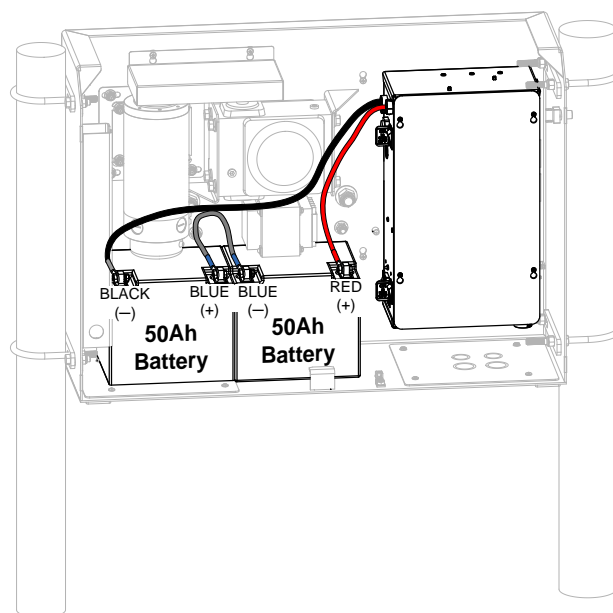

Figure 25. Wired Extended Battery Backup Kit

8. Access the Installer Menu on the Smart DC Controller.
9. Change the Battery Setting (BT) in the Installer Menu to a number 1 (Extended). Follow the steps and see Figure 26–Figure 29:
 - a. Start at a gate status display.



Figure 26. HySecurity Gate Closed

- b. Access the User Menu, by pressing MENU twice.



Figure 27. CT 0 (OFF) Close Timer

- c. Access the Installer Menu, by simultaneously pressing OPEN and RESET. Release the buttons.



Figure 28. LL 0 (OFF) Learn Limit

- d. Use NEXT to navigate to the menu display. Change the setting using the SELECT and NEXT buttons.

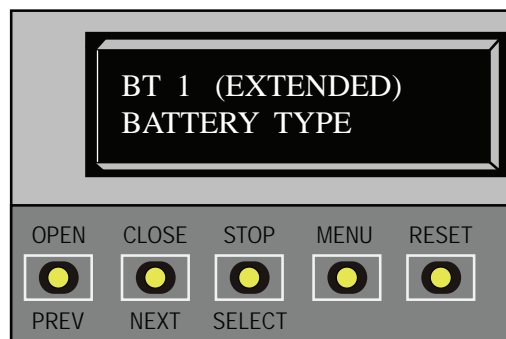

Figure 29. BT1 (EXTENDED) Battery Type

This section of the manual provides information about the display and menu options. It includes how to:

1. Turn both AC and DC power switches on.
2. Review how to use the Smart DC Controller Buttons in Menu Mode
3. Review Run Mode and Gate Status Displays
4. Access and Configure User Menu Options
 - Adjust the Close Timer
 - Set the Time and Date
 - Set the AC Power Loss Gate Function
 - Adjust the Display Contrast
5. Access and Configure Installer Menu Options
 - Reset the OPEN & CLOSE Limits
 - Set the Open and Close Gate Speed
 - Adjust IES Sensitivity
 - Enable Fire Department Access
 - Reinstate Factory Defaults

INITIAL SETUP

Once you have completed the installation of the SlideSmart operator and attached the wired accessories, you're ready to program the operator. Two different approaches exist:

- Connect a laptop computer to the USB or serial (RS-232) port and upload the gate settings and set the operator menu configurations via the START software.

NOTICE

Use a laptop computer at your place of business to conveniently download the free START software from www.hysecurity.com before heading out into the field. This makes it easy to adjust settings using a laptop.

- Manually navigate through the User and Installer Menus using the five buttons located under the LCD display on the Smart Controller. The instructions for performing this second option are provided in this section.

TURNING BOTH POWER SWITCHES ON

AC and DC power switches are located on the outside edge of the control box. See Figure 30.

After "Programming the Initial Setup Menu" on page 23, "Establishing the Open & Close Limits" on page 25, "Installing the Target Magnet" on page 26, and connecting to main power (Power), take the following steps:

1. Turn both power switches ON. The gate moves and searches for the target magnet to re-establish the limits. An audible beep occurs and a red light pulsates next to the OPEN button on the Smart DC Controller which indicates the system is functioning. If AC power is lost, the rate of flashing slows down. Other indicator lights are described below.

NOTICE

If the target magnet is not detected by the operator, "ALERT 15 - NO TARGET" or "LEARN OPEN" appears on the display. For more information, refer to "Installing the Target Magnet" on page 26.

2. When the target magnet is detected, the software version briefly appears on the display, and then one of the following modes appears:
 - Gate status - indicates the operator is in Run Mode. Refer to "Run Mode" on page 38.
 - Alert, fault, and error messages - indicates a problem exists with the operator which needs to be resolved before the operator can function properly. Refer to "Smart DC Controller Troubleshooting" on page 92.

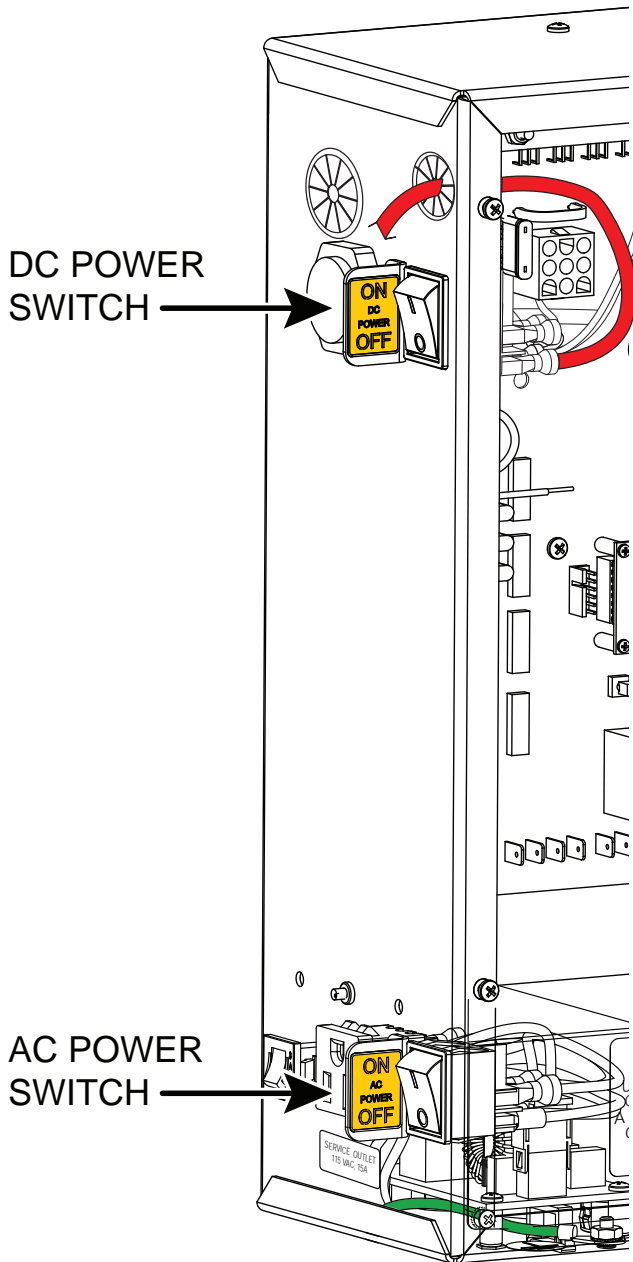

Figure 30. AC/DC Power Switches

NOTICE

The Smart DC Controller can be powered when either switch is turned on. If the DC power switch is OFF the motor and batteries are disconnected. The operator will not function (even though the AC power switch remains on). When the operator is connected to AC power and both switches are turned ON, the charge level of the battery is being monitored and maintained.

The flashing red indicator light next to the OPEN button on the Smart DC Controller is considered the 'heart' beat of the system (see Figure 31). It indicates that the electronics board is receiving power. When AC power is lost, the rate of flashing slows down. Another indicator light, above the display, is multi-colored and corresponds to the action that the operator is performing:

- Green - the operator is stopped.
- Flashing yellow - the operator is running.
- Red - the operator has experienced an error.
- Not lit - AC power is lost. Pressing the SHOW LEDs button indicates which inputs, if any, are active. Refer to Figure 51 for the SHOW LEDs location on the board.

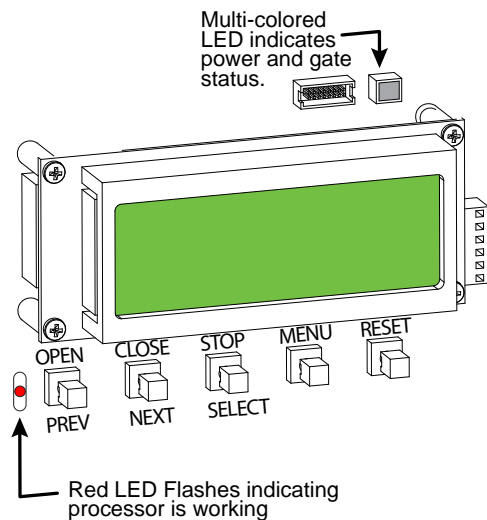

Figure 31. RED Indicator on Smart DC Controller

USING THE SMART DC CONTROLLER BUTTONS IN MENU MODE

Smart DC Controller buttons let you navigate, change, or clear the information in the display menus. Refer to Figure 32.

The buttons with text above and below have two functions. Use these buttons to enter operating commands or navigate through the User and Installer Menus. The singular use of these keys is dependent on the operator mode. Three different modes exist:

- Run Mode - gate is operational awaiting commands. Refer to "Using the Smart DC Controller Buttons in RUN Mode" on page 38.
- Menu Mode - motor disengages and operator commands are ignored. Data entry, menu navigation, and menu selection can be accomplished via the Controller buttons or through a START software connection using the USB port.
- Fault Mode - alerts, faults or errors appear on the display. Some errors or faults can be reset with the STOP button while more serious faults require the RESET button or cycling power. Faults indicate a need for diagnosis and resolution. Refer to "Smart DC Controller Troubleshooting" on page 92.

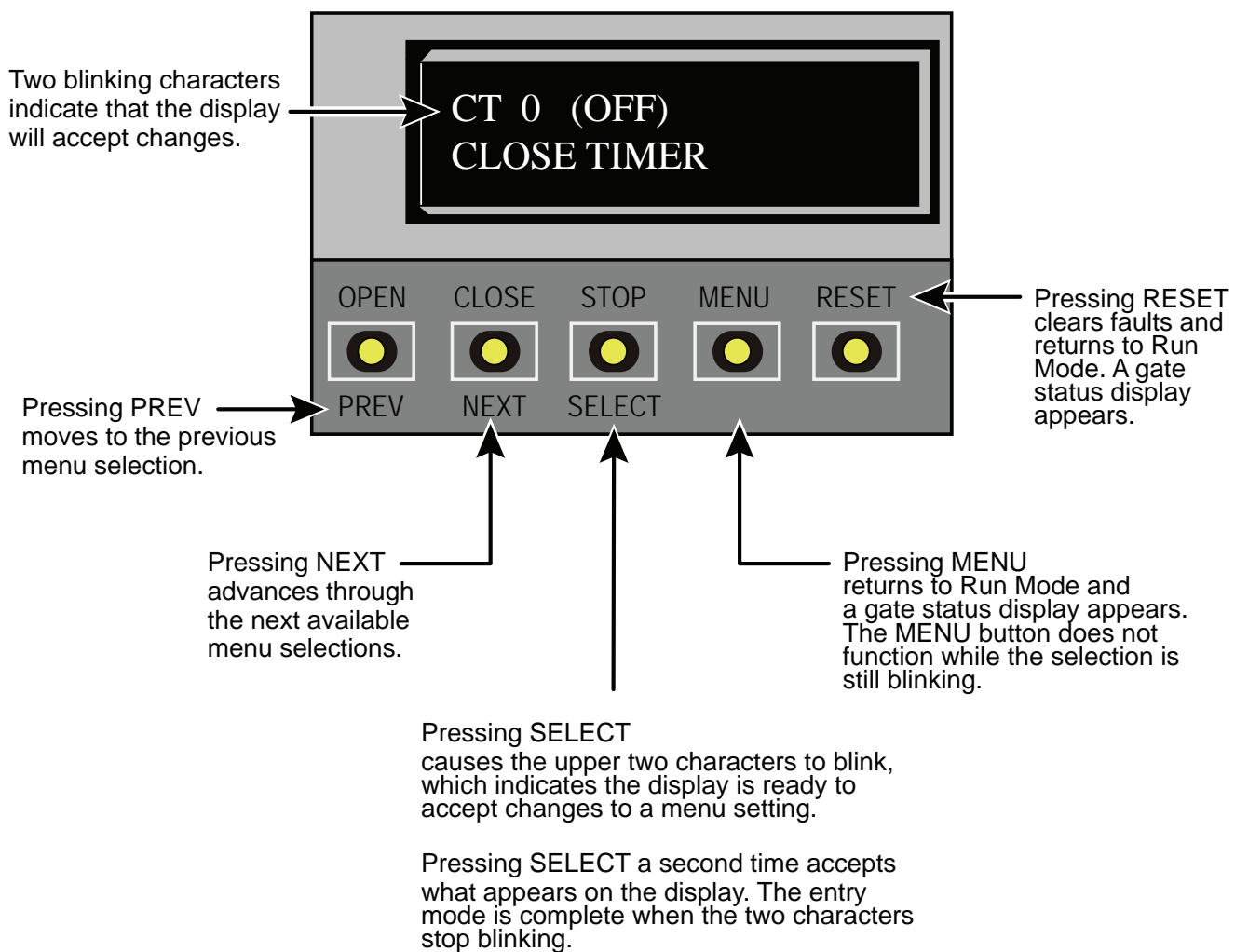

Figure 32. Function of the Smart DC Controller Buttons in Menu Mode

RUN MODE

Gate status displays appear when the operator is ready and waiting for a gate operation command. When the menu display is flashing "GATE OPENING" or "GATE CLOSING" a command has been received which starts the motor and drives the gate. The command may come from a variety of sources: a card reader, pushbutton remote, or recognition of a vehicle passing over a free exit loop detector. In all cases, the operator "runs" the motor when it receives a gate operation command.

Understanding Gate Status Displays

The three gate status displays in Figure 33 indicate the position or status of the non-moving gate. When accessing the User or Installer Menus, you must begin at one of these gate status displays.

NOTICE

While accessing the User or Installer Menus, the motor cannot engage and the gate will not move.



Figure 33. Gate Status Display

USING THE SMART DC CONTROLLER BUTTONS IN RUN MODE

The Run Mode buttons are distinguished by the fact that their name appears above each button. The Controller buttons with text above and below function differently depending on the mode of the operator. Three different modes exist, and see Figure 34:

- Run Mode - gate is operational awaiting commands.
- Menu Mode - motor disengages and operator commands are ignored. Menu navigation and menu selection can be accomplished using the Smart DC Controller buttons or through a START software connection via the USB port. Refer to "Using the Smart DC Controller Buttons In Menu Mode" on page 37.
- Fault Mode - errors, faults or alerts appear on the display. Some errors or faults can be reset with the STOP button while more serious faults require the RESET button or cycling power. Faults indicate a need for diagnosis and resolution. Refer to "Smart DC Controller Troubleshooting" on page 92.

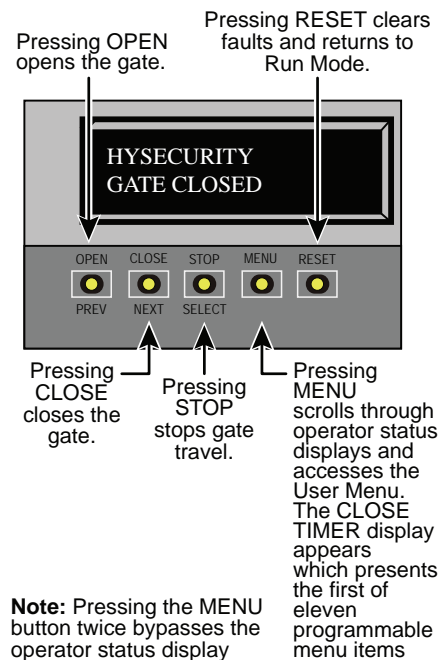

Figure 34. Function of Smart DC Controller Buttons in Run Mode

VIEWING OPERATOR STATUS DISPLAYS

Press the MENU button once and the operator status displays appear in two second intervals. Pertinent information appears to provide a quick overview of the operator's status or configurations. Refer to Table 7.

Table 7. Viewing Operator Status Displays		
Display	Variables	Description
SOFTWARE VERSION H5.##	Software version and revision number are hard-coded in Smart DC Controller.	Displays software version when you press RESET or cycle power. You will need software version when calling Technical Support.
DUAL GATE <PRIMARY>	PRIMARY or SECONDARY (Display only appears when operator is used in dual gate systems.)	Indicates, in a dual gate setting, whether operator is set to Primary or Secondary. Setting is assigned in Installer Menu.
OT <17>D SLIDESMART HD25	OT 17 = SlideSmart HD	Indicates what type of operator the board is programmed as.
<LEFT> HAND	LEFT or RIGHT	Designates which way a gate opens viewed from operator. If it slides left, it is a left-hand gate. Gate handing is established in the initial Setup Menu.
UC <2> USAGE CLASS	1, 2, 3, or 4	Displays operator's Usage Class designation per UL 325 standards. Refer to Identifying Gate Operator Category and Usage Class on page 16.
BT <0> STANDARD BATTERY	0 = 8Ah (standard factory issue) 1 = 50Ah (optional upgrade) 2 = 110Ah (option)	Confirms operator's battery type. If you use larger capacity batteries you must configure operator through Installer Menu. See BT - BATTERY TYPE.
D <32>.0 VDC BATTERY VOLTAGE	Number varies depending on voltage that charger is providing.	Displays actual charging voltage.
CC<002600> CYCLE COUNT	One cycle equals a full open and close sequence.	Displays number of cycles gate operator has incurred. Similar to an odometer, it resets to zero after 999,999 cycles.
CT 0 (OFF) CLOSE TIMER	The first menu item in the User Menu. See "User Menu" on page 40.	NOTE: You can also access Installer Menu from this display. See "Installer Menu" on page 47. Displays number of seconds before open gate initiates

USER MENU

The User Menu consists of several items which can be modified using the Smart DC Controller buttons. Refer to "Using the Smart DC Controller Buttons In Menu Mode" on page 37.

To access the User Menu, take the following steps:

1. At a gate status display, press the MENU button. The operator status displays scroll past and the CLOSE TIMER display appears.

NOTICE

To bypass the operator status displays and access the User Menu, you can press the MENU button.

2. Press the NEXT button to cycle through the available menu items.
3. Review "Table 9. Smart DC Controller - User Menu Functions" on page 44 which supplies the factory defaults for the User Menu items and references the hard-wire connections.

In the pages that follow, a detailed view of the more commonly used menus is provided:

- Adjusting the Close Timer
- Setting the Time & Date
- Setting the AC Power Loss Gate Function
- Adjusting the Display Contrast

For information on how the menu buttons function, review "Using the Smart DC Controller Buttons In Menu Mode" on page 37.

ADJUSTING THE CLOSE TIMER

The close timer assigns how many seconds will pass before the operator initiates automatic closure of a fully opened gate after all open commands and reversing sensor inputs have ceased. Every gate operator should have the close timer set to a specific number of seconds unless a hard-wired closing device is connected to the unit such as a push button station.

To adjust the time (1 to 99 seconds) it takes before the operator initiates gate closure, take the following steps and see Figure 35:

1. At a gate status display, press the MENU button twice. This accesses the User Menu and the CLOSE TIMER display appears.
2. Use the SELECT, and then NEXT or PREV buttons to navigate and change the number on the display.

NOTICE

Keep the close time at zero if gate personnel operate the gate or the owner plans to use a remote control.

3. To exit the User Menu, press the MENU button. The gate status appears in the display indicating you have returned to Run Mode.



Figure 35. CT 0 (OFF) Close Timer

SETTING THE TIME AND DATE

A feature of the Smart DC Controller is its 24-hour, 365 day clock. Make sure it is set to the appropriate time zone. An accurate time and date allows the diagnostic log to date stamp operational data which indicates when Alerts, Faults and Errors occur. The log helps in troubleshooting and can be viewed via a laptop connected to the USB or RS232 port, or on the LCD directly. For more information, refer to "Smart DC Controller Troubleshooting" on page 92.

To set or adjust the time or date, take the following steps and see Figure 36:

1. At a gate status display, press the MENU button twice. This accesses the User Menu and the CLOSE TIMER display appears.
2. Press NEXT or PREV until the SET CLOCK display appears.
3. Press SELECT. CL blinks.
4. Press NEXT or PREV to change the number to 1.
5. Press SELECT to accept the display.
6. The date and time display appears. Use the SELECT and NEXT buttons in the same manner as before to adjust the date and time.

NOTICE

A date or time field must have the blinking arrows below it before it can be changed.

7. To accept what appears on the date and time display, press SELECT.
8. To exit the User Menu, press the MENU button. A gate status appears in the display indicating you have returned to Run Mode.

NOTICE

A lithium coin battery, on the Smart DC Controller board, supports the clock so the date and time is retained even when the main power is turned off. Replace the battery every five years with a DL 2025, DL 2032 or CR 2025 or CR 2032 battery. Refer to "Clock Battery Replacement" on page 110.



1. Start at a gate status display.



2. To access the User Menu, press the MENU button twice.



3. Press NEXT until the SET CLOCK display appears. Use the navigational buttons to select 1.

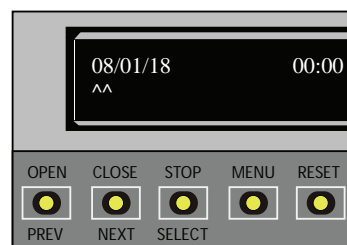

4. Change the time and date using the NEXT and SELECT buttons.

Figure 36. Setting Time and Date

SETTING AC POWER LOSS GATE FUNCTION

The setting in the AC LOSS display determines what action the operator performs during an AC power loss. The settings help reduce drain on the battery. You can choose between four settings depending on customer preferences.

Table 8. AC Power Loss Menu	
Menu Setting	Description
<div style="border: 1px solid black; padding: 5px; width: fit-content;"> AP 0 AC LOSS UPS FAIL OPEN </div>	Normal gate functions continue until system detects battery voltage drop below 21V. DEAD BATTERY appears on display and gate automatically opens. Any pushbutton CLOSE command will close gate and any OPEN command will re-open gate. If battery continues to diminish and system detects 18V or less, system initiates an automatic open cycle. Any new open or close command is ignored and LCD appears blank. System remains in this disabled state until reset or battery recovers to 24V.
<div style="border: 1px solid black; padding: 5px; width: fit-content;"> AP 1 AC LOSS UPS FAIL CLOSE </div>	Normal gate functions continue until system detects a battery voltage drop below 21V. DEAD BATTERY appears on display and gate automatically closes. Gate can be opened by a special sequence of a STOP input followed by an OPEN push-button or directly opened with Fire Department Open command. Any push-button CLOSE command closes gate. If battery continues to diminish and system detects 18V or less, system initiates an automatic open cycle if not already on a limit. Any new open or close command is ignored and LCD appears blank. System remains in this disabled state until reset or battery recovers to 24V.
<div style="border: 1px solid black; padding: 5px; width: fit-content;"> AP 2 AC LOSS AUTO OPEN </div>	Operator automatically opens gate five seconds after AC power loss detected. Gate remains open until AC power is restored. Any push-button CLOSE command will close gate and any open command will open gate. When battery voltage drops below 21V or less, system initiates an automatic open cycle. Gate will remain open until battery recovers to 24V.
<div style="border: 1px solid black; padding: 5px; width: fit-content;"> AP 3 AC LOSS NO CLOSE TIMER </div>	Operator initially does nothing after it detects AC power loss until it receives an open command. Once an open command is received, operator opens and remains in that state. Any push-button CLOSE command will close gate and any open command will open gate. When battery voltage drops below 21V or less, system initiates an automatic open cycle. Gate will remain open until battery recovers to 24V.

To designate what you want operator to do during an AC power loss, access User Menu (see "User Menu" on page 40 and Figure 37) and scroll through items until AP (AC LOSS) display appears:

1. Use SELECT and NEXT buttons to navigate and change number on display. Review "Using the Smart DC Controller Buttons In Menu Mode" on page 37.
2. To exit User Menu, press MENU button. A gate status appears in display indicating you have returned to Run Mode.

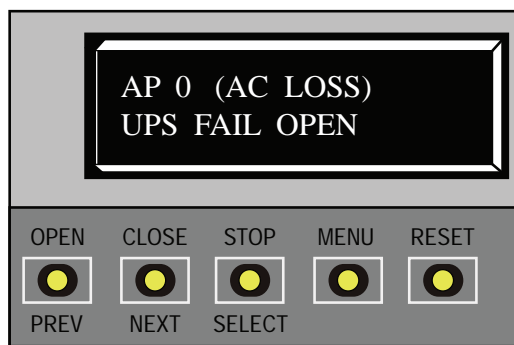

Figure 37. AC Power Loss

ADJUSTING THE DISPLAY CONTRAST

The display contrast can be adjusted from 1 to 9 to increase visibility and ease of use. It is set at the factory to level 5. The text becomes darker as you go up the scale.

NOTICE

If extremely low temperatures are expected, set the contrast to a higher number.

To adjust the contrast (1 to 9), take the following steps and see Figure 38:

1. At a gate status display, press the MENU button twice. This accesses the User Menu and the CLOSE TIMER display appears.
2. Press NEXT until the LCD CONTRAST display appears.
3. Use the SELECT and NEXT buttons to navigate and change the number on the display.
4. To exit the User Menu, press the MENU button. A gate status appears in the display indicating you have returned to Run Mode.



Figure 38. LCD Contrast

DISPLAY AND MENU OPTIONS

Table 9. Smart DC Controller - User Menu Functions

Ref. No.	User Menu Display	Setting Options (Bold = Factory Settings)	Menu Tasks and Explanations	Associated DC Controller Connections
1	CT 0 (OFF) CLOSE TIMER	0 = Timer disabled 1 second to 99 seconds	Assign how many seconds before open gate initiates automatic closure. Keep setting at 0 if a hard-wired, push-button control device is being used. NOTE: CLOSE TIMER display does not appear when HOLD TO CLOSE is set to 1.	Not applicable (N/A)
2	HC 0 (OFF) HOLD TO CLOSE	0 = off 1 = on	Set to 0 produces a gate closure when a momentary signal is transmitted. Set to 1 if a constant hold to close signal, such as a push button control, is being used. A setting of 1 also deactivates automatic close timer and causes its menu to disappear. You must set HC to 1 to comply with UL 325 Type D protection. Refer to Table Notes.	COM CLOSE
3	HO 0 (OFF) HOLD TO OPEN	0 = off 1 = on	Similar to HOLD TO CLOSE, but configures OPEN push button for a constant-hold function. 0 = Momentary open signal 1 = Constant hold open push button required. You must set HO to 1 to comply with UL 325 Type D protection. Refer to Table Notes	COM OPEN
4	AP 0 AC LOSS UPS FAIL OPEN	0 = UPS Fail Open 1 = UPS Fail Close 2 = Auto Open 3 = No Close Timer	Setting designates what action gate performs during an AC power loss. Refer to "Setting AC Power Loss Gate Function" on page 42.	N/A.
5	RO 0 (OFF) RADIO OPEN/CLOSE	0 = off 1 = on	Configures radio input for open only (0). If changed to setting 1 then adds capability for radio input to close gate, but only when gate is fully open.	COM RADIO OPEN

DISPLAY AND MENU OPTIONS

Table 9. Smart DC Controller - User Menu Functions

Ref. No.	User Menu Display	Setting Options (Bold = Factory Settings)	Menu Tasks and Explanations	Associated DC Controller Connections
6	BF 2 (ON 2 SEC) WARN BEFORE OPER	0 = off 1 = on 2 = on	Controls warn-before-operate buzzer and can be configured three ways: Set to 0: Buzzer is disabled. Set at 0, buzzer will still beep when alerts, faults, errors, or entrapment are detected. Set to 1: Buzzer beeps for 3 seconds before gate motion begins and continues through entire gate travel. Set to 2: Buzzer beeps for 3 seconds before gate motion begins and continues for 2 seconds of gate travel.	(N/A) WARNING: Do NOT cut wires to buzzer or unplug it as operator will not be in compliance with UL 325. Failure to comply may result in serious injury or death.
7	PE 0 (OFF) PHOTO EYE ALIGN	0 = off 1 = on	When set to 1, operator serves as an aide in photo-eye emitter/receiver alignment. Buzzer chirps once when emitter and receiver are not aligned. When emitter and receiver are aligned, buzzer chirps twice. If they go out of alignment again, buzzer will chirp once. Alignment Mode is reset with a limit input or reset input.	Sensor Common, Sensor 1, Sensor 2, Sensor 3
8	CL 0 SET CLOCK	0 = Display 1 = Set Clock	To set or adjust minute, hour, day, month or year, select 1. Once clock is set, display automatically returns to 0 setting. Significant gate events are logged and stamped with time and date. This feature is useful to read historical operation data, which can be accessed with a computer via USB or RS232 port or the LG setting in User Menu. See "Setting the Time and Date" on page 41.	(N/A)
9	LD 5 LCD CONTRAST	5 0 through 9	Under some extreme high or low temperature conditions, it may be necessary to adjust LCD contrast. Display is adjustable from 0-9 with a factory default setting of 5.	(N/A)

DISPLAY AND MENU OPTIONS

Table 9. Smart DC Controller - User Menu Functions

Ref. No.	User Menu Display	Setting Options (Bold = Factory Settings)	Menu Tasks and Explanations	Associated DC Controller Connections
10	LG 0 (OFF) VIEW EVENT LOG	0 = off 1 = on	With v5.53 (or later) software, you can set LG to 1 and view abbreviated event logs on the display. These messages are helpful for diagnostic purposes and reviewing the gate operator's event history. Over 300 events can be logged before the software begins overwriting the existing history.	(N/A)
11	DS 0 (OFF) DIAGNOSTIC LOGS	0 = off (standard) 1 = on (detailed)	Set this item to 1 to record all gate operator open and close events, in addition to normal alert, fault and error logs. This parameter automatically resets to the default 0 (off) after 24 hours, which is useful when experiencing intermittent problems. Set to 0, DC Controller logs pertinent gate operator events such as faults, errors, or menu manipulation.	USB or RS232 cable and laptop computer with HySecurity's free START software is required to read log file.

Table Notes:

The following conditions apply to the indicated reference-numbered menu selections:

Table Note 1:

For gate operators using Type D entrapment protection, an automatic closing device (such as a timer, loop sensor, or similar device) shall not be employed.

Table Note 2:

WARNING: Do NOT cut the wires to the buzzer or unplug it as the operator will not be in compliance with UL 325. Failure to comply may result in serious injury or death.

INSTALLER MENU

The Installer Menu consists of several functions which can be modified using the Smart DC Controller buttons or configured through the use of a laptop computer and the START software available from the HySecurity website.

The Installer Menu options provide more advanced configurations for the SlideSmart operator. Access to the Installer Menu is through the User Menu. The navigational buttons are the same in both menu modes. To review how to use the navigational buttons on the Smart DC Controller, refer to "Using the Smart DC Controller Buttons In Menu Mode" on page 37.

NOTICE

To access the User or Installer Menus, the operator must be in Run Mode with a gate status showing on the display. The motor cannot be engaged and the gate cannot be moving.

To access the Installer Menu, take the following steps:

NOTICE

The menu items, Usage Class, Gate Handing, and Gate Weight must be configured before the operator will function. Refer to "Programming the Initial Setup Menu" on page 23.

1. Start at a gate status display. To bypass the Operator Status Displays, press the MENU button twice. See Figure 39.



Figure 39. HySecurity Gate Closed

2. To access the Installer Menu simultaneously press OPEN and RESET. See Figure 40



Figure 40. Close Timer

NOTICE

The CLOSE TIMER display appears indicating you have accessed the User Menu.

3. Release buttons and LEARN LIMITS display appears indicating Installer Menu access. LEARN LIMITS display is first item in the Installer Menu. See Figure 41.



Figure 41. Learn Limit

In the following pages, a detailed view of the more commonly used menus is provided.

- Resetting the OPEN & CLOSE limits
- Adjusting the Gate Speed
- Adjusting the IES Sensitivity
- Enabling the Fire Department Override
- Reinstating Factory Defaults

"Table 10. Smart DC Controller - Installer Menu Functions" on page 54 describes Installer Menus, supplies factory defaults, and references hard-wire connections. For information on how menu buttons function, review "Using the Smart DC Controller Buttons In Menu Mode" on page 37.

DISPLAY AND MENU OPTIONS

RESETTING THE OPEN AND CLOSE LIMITS

On occasion, the open and close limits may need to be fine-tuned. Resetting the open and close limits is easily accomplished by accessing the Installer Menu. Examples where resetting the limits is necessary, include:

- Replacing the chain or adjusting the chain to the point where it affects the open and close positions
- Removing or replacing the target magnet
- Setting the LEARN LIMITS display to 1 (erases the open and close target positions from memory).

To re-learn limits, take the following steps and see Figure 42:

1. At a gate status display, press the MENU button twice. The CLOSE TIMER display appears.
2. Simultaneously, press the OPEN and RESET buttons to enter the Installer Menu. Release the buttons and the LEARN LIMITS display appears. It is the first item in the Installer Menu.
3. Press SELECT, and then NEXT to change the setting to 1. Press SELECT again. LEARN OPEN flashes on the display indicating that operator is ready to relearn the open limit.
4. Hold the OPEN button until the gate reaches the desired open limit. Release the OPEN button. (Note that if you go too far, you can press CLOSE to reverse direction.)
5. Press STOP twice to preserve the open stop location. LEARN CLOSE appears on the display.
6. Hold the CLOSE button until the gate slides to full close. Release the CLOSE button (Note that if you go too far, you can press OPEN to reverse direction.)
7. Press STOP twice. The full close stop is retained in memory. For more information, refer to "Establishing the Open & Close Limits" on page 25.

8. An ALERT 15 message appears on the display. To clear the alert, perform a full cycle so the software recognizes the target. Press OPEN, and then CLOSE. The gate will stop automatically on the close cycle when it reaches the programmed limit. As the target magnet passes the sensor, the operator beeps and the ALERT 15 message is cleared.

NOTICE

Do not set limits at the physical OPEN and CLOSE stops. Leave a 1 to 2-inch (2.5 - 5cm) gap to allow for minimal drift.



1. Start at a gate status display.



2. To access the User Menu, press the MENU button twice.

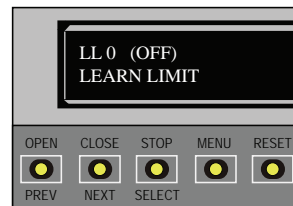

3. Access the Installer Menu, by simultaneously, pressing the OPEN and RESET buttons.



4. Press SELECT and change the setting to 1 using the NEXT button. Press SELECT again. The LEARN OPEN display appears. Refer to steps 4 through 8.

Figure 42. Resetting OPEN and CLOSE Limits

ADJUSTING GATE SPEED

The gate speed can be increased or decreased a ¼ foot per second from the operator's default speed.

NOTICE

Two options, one for OPEN SPEED the other for CLOSE SPEED, appear in the Installer Menu. The steps involved in changing the open speed are shown below. The steps to set the close speed are the same, you just need to access the CLOSE SPEED option.

To adjust the gate speed, take the following steps and see Figure 43:

1. At a gate status display, press the MENU button twice. The CLOSE TIMER display appears.
2. Simultaneously, press the OPEN and RESET buttons to enter the Installer Menu. Release the buttons and the LEARN LIMITS display appears. It is the first item in the Installer Menu.
3. Press NEXT until the OPEN SPEED (or CLOSE SPEED) display appears. Select the desired setting based on the operator type:

SlideSmart HD15F, HD25, HD30 (Usage Class 3 & 4 only)	0 = 0.75 ft/s
	1 = 1.0 ft/s
	2 = 1.25 ft/s
	3 = 2.25 ft/s

NOTICE

Certain speeds are allowed only when the operator's Usage Class is set appropriately.

4. Use the SELECT and NEXT buttons to navigate and change the speed setting on the display.
5. To exit the Installer Menu, press the MENU button. The gate status appears in the display indicating you have returned to Run Mode.



1. Start at a gate status display.



2. To access the User Menu, press the MENU button twice.



3. Access the Installer Menu, by simultaneously, pressing the OPEN and RESET buttons.



4. Use NEXT to navigate to the menu display. Change the setting using the SELECT and NEXT buttons.

Figure 43. Adjusting Gate Speed

ADJUSTING THE IES SENSITIVITY

SlideSmart uses a primary Type-A inherent entrapment sensor (IES) per UL325 Safety Standards. A solid immovable object blocking the gate will trip the IES and cause the operator to stop and reverse (for two seconds) and enter safe mode.

The adaptive IES software monitors the average running motor current while the gate is in motion and reverses the gate when the current exceeds an automatically self-adapting threshold.

The IES display, accessed through the Installer Menu, allows you to input a number between 0 and 9. The settings (0 through 6) allow an increasingly higher threshold (amount of headroom) above the average current draw before tripping. For IES settings 7 through 9, the current limit is a fixed relatively high current value before the IES will be tripped. The factory setting is 2, which is adequate for most sites. See Figure 44 and Figure 45

CAUTION

Avoid setting the IES sensitivity to a fixed level (7 - 9 setting). The high motor current required for the IES to trip could cause severe injury or death to people caught in the moving gate.

For IES settings (0 through 6), the motor current is continually being measured and the IES threshold automatically set to trip at peak motor current plus the additional "headroom" provided by the IES setting selected.

To prevent false IES trips, the software boosts the IES current threshold for one gate cycle after an IES event, then returns to the normal sensitivity threshold.

Over time, degrading gate hardware and other site issues, such as road settling or debris on the gate rail (V-track) can occur. As the gate hardware ages and becomes stiffer, the SlideSmart motor current increases and this may create the need to use a higher IES setting level. The higher settings should only be used on a TEMPORARY basis until the gate, gate track, or wheels are repaired so the gate rolls smoothly with minimal resistance.



Figure 44. IES Sensitivity

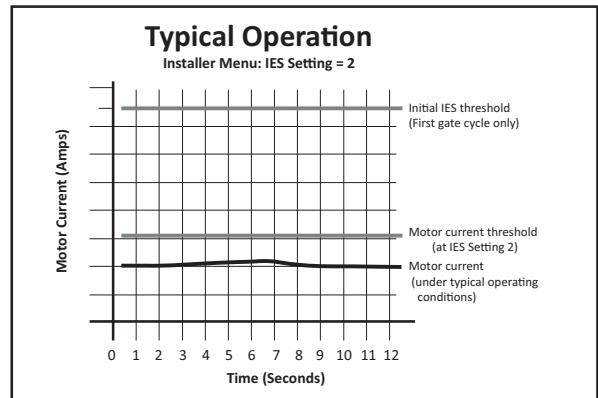

NOTE: When wind load increases, IES software adapts and changes the threshold allowance. The IES threshold automatically increases by 50% when the temperature drops below 32°F.

Figure 45. IES Sensitivity Chart

NOTICE

When changing the IES setting, consider the site design and vehicular gate traffic. It is recommended that you use the most sensitive setting while still allowing for reliable gate operation.

Examples of conditions which affect IES sensitivity include:

Gate design - For long and/or solid gates in windy environments, large variations in motor current may occur. In these types of scenarios, you may want to use a higher (less sensitive) IES setting.

Gate condition - If the gate environment is near salty sea air, rusty wheels or chains might impede gate travel over time. Additionally, gates that are hit and bent may have very stiff areas during travel that cause a large variation in motor current. For these issues, you may want to use a higher (less sensitive) IES setting until repairs are made.

DISPLAY AND MENU OPTIONS

Gate maintenance - Gate rollers will deteriorate and begin to fail over time. Gravel or dirt roads will incur more debris in the gate rail or inverted V-track than a paved surface. In poorly maintained gate areas, the chance for false IES trips is higher.

To adjust the IES sensitivity, take the following steps and see Figure 46:

1. At a gate status display, press the MENU button twice. The CLOSE TIMER display appears.
2. Simultaneously, press the OPEN and RESET buttons to enter the Installer Menu. Release the buttons and the LEARN LIMITS display appears.
3. Press NEXT until the IES SENSITIVITY display appears. The factory default setting is 2.

CAUTION

Avoid setting the IES sensitivity to a fixed level (7 - 9 setting). The high motor current required for the IES to trip could cause severe injury or death to people caught in the moving gate.

4. Use the SELECT and NEXT buttons to navigate and change the number on the display.
5. To exit the Installer Menu, press the MENU button. The gate status appears in the display indicating you have returned to Run Mode.

If IES trips occur, SAFE MODE or ENTRAPMENT MODE will appear on the display. For more information about troubleshooting, refer to "Table 16. Smart DC Controller - Troubleshooting" on page 92.



1. Start at a gate status display.



2. To access the User Menu, press the MENU button twice.



3. Access the Installer Menu, I simultaneously, pressing the OPEN and RESET buttons.



4. Use NEXT to navigate to the menu display. Change the setting using the SELECT and NEXT buttons.

Figure 46. Adjusting IES Sensitivity

REINSTATING FACTORY DEFAULTS

Eleven menu configurations are available in the User Menu. Several other items in the Installer Menu let you customize the operator depending on the number of attached accessories and your customer's needs.

CAUTION

Reinstating factory default clears ALL menu settings stored in the operator and returns them to factory defaults. It is recommended that you save the menu settings before reinstating factory defaults. You can write the settings in a notebook or, if you have a laptop computer, you can use HySecurity's START software and download the menu settings and save them to a file to upload to the operator at a later date.

To reinstate factory defaults, take the following steps and see Figure 47:

1. At a gate status display, press the MENU button twice. This accesses the User Menu and the CLOSE TIMER display appears.
2. Simultaneously, press the OPEN and RESET buttons to enter the Installer Menu. Release the buttons and the LEARN LIMITS display appears. It is the first item in the Installer Menu.
3. Press NEXT until the FACTORY DEFAULTS display appears. Factory default setting is 0.
4. Use the SELECT and NEXT buttons to navigate and change the number on the display to 1.

NOTICE

When you press SELECT to accept FD 1, the factory settings are reinstated immediately and the menu display returns to the initial Setup Menu. The gate operator will not run until the three menu parameters are entered: Usage Class, Gate Handing, and Gate Weight along with Sensor 1, 2, 3. The limits will also need to be relearned. Refer to "Programming the Initial Setup Menu" on page 23 and "Establishing the Open & Close Limits" on page 25.



1. Start at a gate status display.



2. To access the User Menu, press the MENU button twice.



3. Access the Installer Menu, by simultaneously, pressing the OPEN and RESET buttons.



4. Use NEXT to navigate to the menu display. Change the setting using the SELECT and NEXT buttons.

Figure 47. Reinstating Factory Defaults

ENABLING FIRE DEPARTMENT OVERRIDE

Many counties and cities require a Fire Department override system for gate operators. The fire department's alert system is a separate unit that must be connected to the Smart DC Controller. FIRE DEPARTMENT OPEN option must be properly configured through Installer Menu before operator will recognize alert system.

To enable Fire Department Override, take following steps and see Figure 48 and Figure 49:

1. Connect the NO contact from the alert system or key switch to the following Smart DC Controller terminals: EMERG OPEN and +24V.
2. Configure the Installer Menu. At a gate status display, press the MENU button twice. This accesses the User Menu and the CLOSE TIMER display appears.
3. Simultaneously, press the OPEN and RESET buttons to enter the Installer Menu. Release the buttons and the USAGE CLASS display appears. It is the first item in the Installer Menu.
4. Press NEXT until the FIRE DEPARTMENT OPEN display appears. The factory default setting is 0.
5. Use the NEXT button to change the number on the display to 1 and then press SELECT.
6. To exit the Installer Menu, press the MENU button. The Gate status appears in display indicating you have returned to Run Mode.

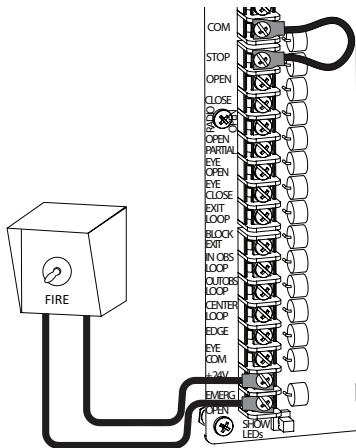

Figure 48. Fire Department Override Wiring



1. Start at a gate status display.



2. To access the User Menu, press the MENU button twice.



3. Access the Installer Menu, by simultaneously, pressing the OPEN and RESET buttons.



4. Use NEXT to navigate to the menu display. Change the setting using the SELECT and NEXT buttons.

Figure 49. Fire Department Override Commands

DISPLAY AND MENU OPTIONS

Table 10. Smart DC Controller - Installer Menu Functions







Ref. No.	User Menu Display	Setting Options (Bold = Factory Settings)	Menu Tasks and Explanations	Associated DC Controller Display Connections
1		0 = Normal operation 1 = Reset limits	A setting of 1 places operator into its learn limits mode which allows you to reset gate's open and close positions. Refer to "Resetting the OPEN and CLOSE Limits" on page 48.	Not applicable (N/A)
2		0 = Gate disabled 1 = Residential 1 to 4 units 2 = Comm./public access 3 = Light industria 4 = Industrial secure	Assign operator's Usage Class designation per UL 325 standards. See Identifying Gate Operator Category and Usage Class on page 16. The installer must designate a usage class before operator will function. See "Programming the Initial Setup Menu" on page 23.	(N/A)
3		0 = Gate disabled R = Right hand L = Left hand	Handing determines which way gate opens as you view it from operator side. If gate handing is changed after initial setup, operator resets limits. LEARN OPEN display appears when you exit Installer Menu. See "Programming the Initial Setup Menu" on page 23.	(N/A)
4		0 = Gate disabled 1, 2, 3, or 4 Gate weight selections appear in pounds. See "Table 3. Programming Initial Setup Menu" on page 24.	Select gate's weight range in pounds. Correct gate weight allows operator to determine appropriate acceleration and deceleration rates. See "Programming the Initial Setup Menu" on page 23.	(N/A)
5		OT 17 0 = 0.75 ft/s 1 = 1.00 ft/s 2 = 1.25 ft/s	Designate how quickly gate opens: 0.75 ft/s – 1.25 ft/s. Setting of 2 reserved for Usage Class 3 and 4.	(N/A)
6		OT 17 0 = 0.75 ft/s 1 = 1.00 ft/s 2 = 1.25 ft/s	Designate how quickly gate closes: 0.75 ft/s – 1.25 ft/s. Setting of 2 reserved for Usage Class 3 and 4.	(N/A)

Table 10. Smart DC Controller - Installer Menu Functions

Ref. No.	User Menu Display	Setting Options (Bold = Factory Settings)	Menu Tasks and Explanations	Associated DC Controller Display Connections
7	FD 0 (OFF) FACTORY DEFAULTS	0 = custom user settings 1 = reload factory default settings	Globally restores all menu settings back to new operator status. Select setting 1 to return operator to factory defaults. NOTE: If factory defaults are restored, the UL usage class, handing, gate weight, and any other modified menu settings will need to be reprogrammed.	(N/A)
8	DG 0 (OFF) DUAL GATE	0 = solo operator 1 = Secondary unit 2 = Primary unit 3 = Sally Port A 4 = Sally Port B	Configures gate operator as a Primary or as a Secondary in a dual-gate installation. When you assign one unit as Primary, you must configure other as Secondary through Installer Menu. This menu is also used to configure a Sally Port system by setting one operator to Sally Port A and the other to Sally Port B.	3-wire shielded cable to DUAL GATE input terminals. Connect Dual Gate COM (Gate 1) to Dual Gate COM (Gate 2). Pair wires: A - A, COM - COM, and B - B
9	SG 0 (OFF) SEQUENCED GATE	0 = solo operator 1 = Loop View #1 2 = Loop View #2 3 = Loop View #3 4 = Loop View #4	Establishes communication after wiring two or more gate operators as sequential gates. This SG menu item only appears if the Dual Gate menu item (DG) is set to 0 (solo operator). NOTE: After selecting SG settings, consider accessing the User Menu in each gate operator to address the Close Timer (CT) setting.	3-wire shielded cable to DUAL GATE input terminals on both operators. Pair wires: A - A, COM - COM, and B - B

DISPLAY AND MENU OPTIONS

Table 10. Smart DC Controller - Installer Menu Functions

Ref. No.	User Menu Display	Setting Options (Bold = Factory Settings)	Menu Tasks and Explanations	Associated DC Controller Display Connections
10	CH 0 (AC) CHARGER TYPE	0 = AC powered charger 1 = Solar	Assigns charger type usually set at factory. If set to solar at factory then this menu item is hidden.	(N/A)
11	BT 0 (STANDARD) BATTERY TYPE	0 = standard (8Ah) 1 = extended (50Ah) 2 = maximum (110Ah)	Assign battery type used by operator. NOTE: Smaller batteries are charged with less current to avoid overheating and larger batteries are charged with more current to supply a more rapid charge.	Extended (50Ah) batteries require wire extensions. Maximum (110Ah) batteries require separate housing and wiring.
12	FO 0 (OFF) FIRE DEPT OPEN	0 = disabled 1 = enabled	Enables Fire Department Open input. When set to 1, signal received through this input overrides all photoelectric eyes and edge sensors and opens gate. Pressing RESET button (or the OPEN push button) is required before gate can be closed.	+24V DC EMERG OPEN
13	SE 2 IES SENSITIVITY	0 = maximum sensitivity 2 = default Setting 9 = least sensitivity	Adjusts sensitivity of internal inherent entrapment sensor (IES). Available settings are 0 to 9 with 9 being least sensitive. HySecurity strongly recommends that you avoid setting IES sensitivity higher than 6. NOTE: Before changing IES sensitivity, make sure that gate rolls smoothly without obstruction. Fix any issues with gate hardware.	See Note.
14	SS 0 (OFF) IES STOP ONLY	0 = stop, reverse for 2s 1 = stop only	In a Usage Class 4 environment, operator can be set to stop gate and not reverse gate travel after an IES trip.	(N/A)

DISPLAY AND MENU OPTIONS

Table 10. Smart DC Controller - Installer Menu Functions

Ref. No.	User Menu Display	Setting Options (Bold = Factory Settings)	Menu Tasks and Explanations	Associated DC Controller Display Connections
15	LC 0 (0.0 SECS) LEAF DELAY CLOSE	0 = no delay 1 through 20 in ½ second increments For example: 1 = ½ second 10 = 5 seconds 20 = 10 seconds	Only appears if gate operator is set up as a Primary or a Secondary. Available settings are 1 through 20. Each increment adds ½ second time delay following a command to close before operator begins closing. Provides up to a 10 second time delay.	DUAL GATE inputs on both operators
16	LO 0 (0.0 SECS) LEAF DELAY OPEN	0 = no delay 1 through 20 in ½ second increments For example: 1 = ½ second 10 = 5 seconds 20 = 10 seconds	Only appears if gate operator is set up as a Primary or a Secondary. Available settings are 1 through 20. Each increment adds ½ second time delay following a command to open before operator activates. Provides up to a 10 second time delay.	DUAL GATE inputs on both operators
17	RT 0 (60 SECS) MAXIMUM RUN TIMER	0 = 60 Seconds max run, 1 = 300 Seconds max run	Doesn't appear in SlideSmart. Assigns a motor run time of 60 or 300 seconds. If the gate opening or closure takes longer than 60 seconds, you'll need to set the run timer to 1.	(N/A)
18	PO 0 (OFF) PARTIAL OPEN	0 = OFF 7 = 7 ft, 8 = 8ft, through 32 = 32 ft	Sets distance (from closed gate position) where gate stops if the partial open input is activated. When a number is entered in PO display, open partial input becomes operational.	OPEN PARTIAL COM
19	EC 0 (STOP ONLY) EYE CLOSE LOGIC	0 = Close eye stops only 1 = 2s reverse to open 2 = Full Open	Default setting is non-reversal if close photo eye is triggered while closing. A setting of 1 causes gate to reverse toward open for two seconds if triggered while closing. A setting of 2 reverses the gate to full open.	Sensor Common Sensor Input

DISPLAY AND MENU OPTIONS

Table 10. Smart DC Controller - Installer Menu Functions

Ref. No.	User Menu Display	Setting Options (Bold = Factory Settings)	Menu Tasks and Explanations	Associated DC Controller Display Connections
20	EO 0 (STOP ONLY) EYE OPEN LOGIC	0 = Open eye stops only 1 = 2s reverse to close	Default setting is non-reversal if open photo eye is triggered while opening. A setting of 1 causes gate to reverse travel and close for two seconds if triggered while opening.	Sensor Common Sensor Input
21	GR 0 (FULL OPEN) GATE EDGE LOGIC	0 = Edge reverses full open 1 = 2s reversal only	Default setting is a full-open reversal if gate edge is triggered while closing. Optional setting of 1 causes gate to reverse for two seconds if triggered while closing.	Sensor Common Sensor Input
22	SR 1 REVERSE 2S IES SENSOR LOGIC	0 = IES reverses full open 1 = 2 second reversal only	Default setting is a two-second duration reversal if inherent sensor is triggered. Optional setting of 0 will cause gate to reopen fully if triggered while closing.	(N/A)
23	PC 1 NO CONTACT PHOTO EYE OUTPUT	0 = Normally Open PE output 1 = Normally Closed (supervised)	This menu item only appears when UC is set to 4. Default setting is photo eyes with Normally Close outputs. Optional setting 0 requires a Normally Open (NO) output. When set for NC, connection is monitored and any short circuit fault will generate a FAULT 2 alert which requires a STOP or RESET button press to re-enable gate operation.	Photo eye connections: Sensor Common Sensor Input +24V
24	GC 1 NO CONTACT GATE EDGE OUTPUT	0 = Normally Open Edge 1 = Normally Closed	This menu item only appears when UC is set to 4. Default setting is edge sensor with Normally Closed (NC) output. Optional setting of 0 requires an (NO) output.	Sensor Common Sensor Input

DISPLAY AND MENU OPTIONS

Table 10. Smart DC Controller - Installer Menu Functions

Ref. No.	User Menu Display	Setting Options (Bold = Factory Settings)	Menu Tasks and Explanations	Associated DC Controller Display Connections
25	S1 0 SENSOR #1 TYPE	0 - disabled 1 - (NOT USED) 2 - (EYE CLOSE) 3 - (EDGE CLOSE) 4 - (EYE OPEN) 5 - (EDGE OPEN) 6 - (EDGE BOTH) 7 - (EYE BOTH)	UL 325 - 2018 sensor input setting for external entrapment protection sensor monitoring. All three sensor types must be configured to a non-zero number before the gate operator will move the gate. Edge Both is only available in Swing Gate operator types. Eye Both is only available in Slide Gate operator types.	
26	S2 0 SENSOR #2 TYPE	Same as Sensor 1	Same as Sensor 1	
27	S3 0 SENSOR #3 TYPE	Same as Sensor 1	Same as Sensor 1	
28	DT 0 FREE EXIT DISABLE FUNCTION	0 = Disable Free Exit 1 = Disable Close Timer	Configures BLOCK EXIT input to disable either Free Exit Detector function or, alternately, Close Timer function. Default setting disables free exit detector. NOTE: Free exit is disabled when gate is at its closed limit. If closed limit is not tripped, free exit continues to work normally.	BLOCK EXIT COM
29	OR 1 REVERSE OUTSIDE OBS LOOP	0 = Pause closing only 1 = Enable reverse to open	Default is for full reversal when Outside Obstruction Loop is triggered while closing. A setting of 0 causes gate to only pause when triggered. Gate closure continues as soon as loop is clear again.	OUTSIDE OBS LOOP COM or Hy5B

DISPLAY AND MENU OPTIONS

Table 10. Smart DC Controller - Installer Menu Functions



Ref. No.	User Menu Display	Setting Options (Bold = Factory Settings)	Menu Tasks and Explanations	Associated DC Controller Display Connections
30		0 = Pause closing only 1 = Enable reversing to open	Default is for full reversal when Inside Obstruction Loop is triggered while closing. A setting of 0 causes gate to only pause when triggered. Closure begins as soon as loop is clear again.	INSIDE OBS LOOP COM or Hy5B
31		1 = Standard 2 = Quick closed 3 = Forced Time out 4 = Full anti-tailgate	This selection determines whether close timer begins to count down after vehicles have departed detector loops or whether close timer will count down while the loops are occupied. Gate can only close when all loop detectors are clear. Default settings causes Close Timer to start when all loops are clear. A setting of 2 causes Close Timer to start when open limit is reached. A setting of 3 forces the Close Timer to 0 when the OOLD and IOLD are tripped simultaneously. A setting of 4 stops the gate when OOLD and IOLD are tripped simultaneously and closes from that point when the loops clear.	Hy5B

Table 10. Smart DC Controller - Installer Menu Functions

Ref. No.	User Menu Display	Setting Options (Bold = Factory Settings)	Menu Tasks and Explanations	Associated DC Controller Display Connections
32	<div style="border: 1px solid black; padding: 2px; width: fit-content;"> RL 1 0 DISABLED RELAY 1 LOGIC </div>	0 = default 1 to 45 available	Configures function of the user 1 output relay, which is an electromechanical relay. It has capacity to switch, both AC and DC and can be used for high voltage and/or high current loads. Connect devices directly to the top of relay: COM plus NO and NC contacts. Up to 45 optional relay functions exist. See "Figure 62. Setting the User Relay Function in the Installer Menu" on page 83.	User 1 Relay
33	<div style="border: 1px solid black; padding: 2px; width: fit-content;"> RL 2 1 CLOSE LIMIT RELAY 2 LOGIC </div>	0 = default 1 to 45 available	Configures function of user output relay, which is an electronic relay with capacity for switching a DC load only. The User 2 Relay is limited to 48 Volts DC and 4A maximum load. Up to 45 optional relay functions exist. See "Figure 62. Setting the User Relay Function in the Installer Menu" on page 83.	User 2 Relay
34	<div style="border: 1px solid black; padding: 2px; width: fit-content;"> RL 3-10 1 CLOSE LIMIT RELAY 3-10 LOGIC </div>	0 = Disabled Up to 45	Similar to Relay 1 Logic. NOTE: The Hy8Relay™ module option can be purchased for eight additional NO relay outputs. Relay #39 set aside for Factory Use.	User 3 -10 Relay
35	<div style="border: 1px solid black; padding: 2px; width: fit-content;"> TL 2 (45 SECS) OPEN TIME ALERT </div>	0 = 0 seconds 1 = 15 seconds 2 = 45 seconds 3 = 75 seconds 4 = 105 seconds 5 = 135 seconds	Adjusts time delay before activating a user relay. Maximum time setting is 135 seconds. See "Figure 62. Setting the User Relay Function in the Installer Menu" on page 83. NOTE: This menu controls a user relay set to Function No. 8	User relays

DISPLAY AND MENU OPTIONS

Table 10. Smart DC Controller - Installer Menu Functions

Ref. No.	User Menu Display	Setting Options (Bold = Factory Settings)	Menu Tasks and Explanations	Associated DC Controller Display Connections
36	LT 3 (75 SECS) LOITERING ALERT	0 = 0s delay 1 = 15s 2 = 45s 3 = 75 second delay 4 = 105s 5 = 135s	This function monitors activation of Outside Obstruction Loop when the gate is closed and not running. When adjustable period of time is exceeded, User Relay No. 13 triggers and reports loitering in diagnostics log. Adjust time delay before activating user relay. Maximum time setting is 135 seconds. See "Figure 62. Setting the User Relay Function in the Installer Menu" on page 83. NOTE: This menu controls a user relay set to Function No. 13	User relays
37	SA 0 (OFF) STC ADDRESS	0 = No network 1 to 99 Network "drop" address	Set system address for network communication: 0 = no network communication 1 - 99 sets individual polling addresses. Use addresses 1-4 when connecting to HyNet.	RS-485
38	ELD 0 (RUN MODE) EXIT LOOP SET	0 = Run mode 1 = Show frequency 2 = Show call level 0-7 3 = Set Frequency	Controls Hy5A or Hy5B Free Exit detector. If an Hy5B is used, additional settings of 4-8 are available.	Hy5B
39	ILD 0 (RUN MODE) IN OBS LOOP SET	0 = Run mode 1 = Show frequency 2 = Show call level 0-7 3 = Set Frequency	Controls Hy5A or Hy5B Inside Obstruction Loop detector. If an Hy5B is used, additional settings of 4-8 are available.	Hy5B

Table 10. Smart DC Controller - Installer Menu Functions

Ref. No.	User Menu Display	Setting Options (Bold = Factory Settings)	Menu Tasks and Explanations	Associated DC Controller Display Connections
40	<div style="border: 1px solid black; padding: 5px; width: fit-content;"> OLD 0 (RUN MODE) OUT OBS LOOP SET </div>	0 = Run mode 1 = Show frequency 2 = Show call level 0-7 3 = Set Frequency	Controls Hy5A or Hy5B Outside Obstruction Loop detector. If an Hy5B is used, additional settings of 4-8 are available.	Hy5B
41	<div style="border: 1px solid black; padding: 5px; width: fit-content;"> CLD 0 (RUN MODE) CENTER LOOP SET </div>	0 = Run mode 1 = Show frequency 2 = Show call level 0-7 3 = Set Frequency	Controls Hy5A or Hy5B Center Loop (Shadow) detector. If an Hy5B is used, additional settings of 4-8.#22.	Hy5B

SMART DC CONTROLLER

This section provides information about the Smart DC Controller board; its inputs for peripheral connections and its monitoring capabilities. This section explains how to:

1. Make connections on the Smart DC Controller
2. Connect Vehicle Detector
3. Connect Accessory Devices
 - Entrapment Sensor Connections
 - Access Controls
 - Manual Push-button Station
 - User Relays

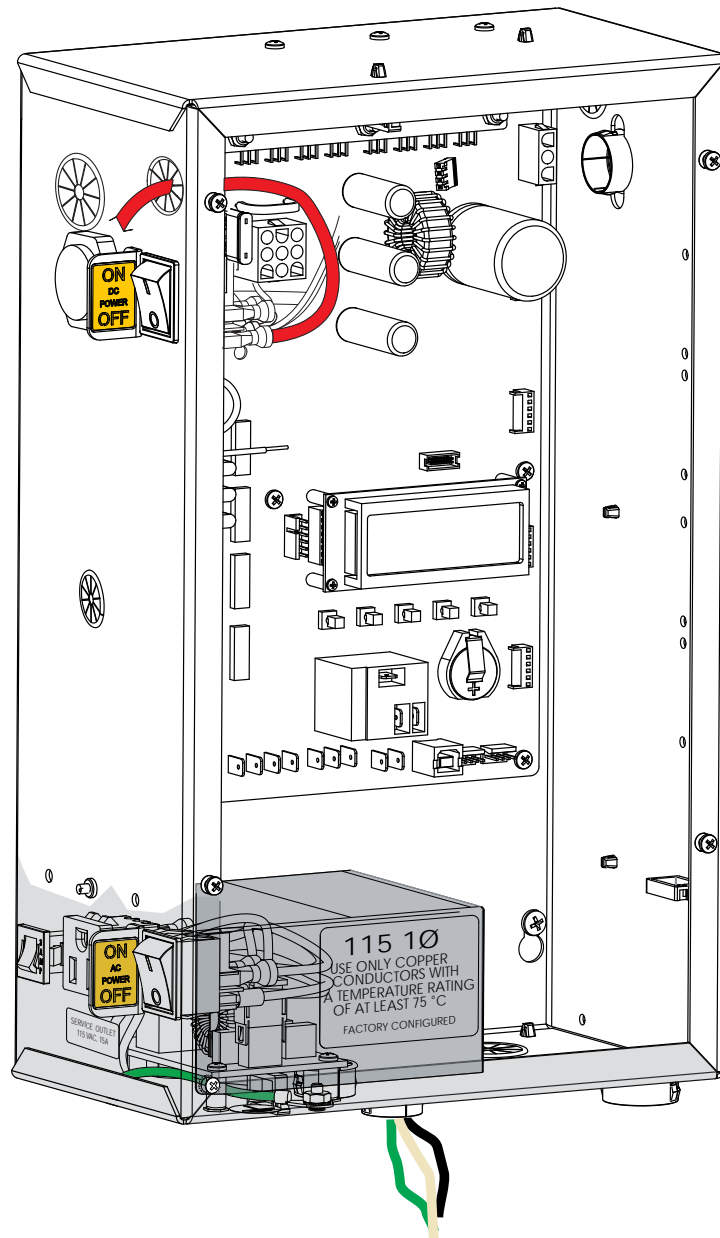

Figure 50. Smart DC Control Box

OVERVIEW OF THE SMART DC CONTROLLER

The Smart DC Controller uses LED's to indicate active inputs when AC power is present. For operators that use only DC power, you can push a button to show the active inputs. This button is at the bottom left corner near the EMERG OPEN input.

On a new operator no active inputs should appear until external accessories and wiring are attached. If any inputs are active before connecting external wiring, refer to "Smart DC Controller Troubleshooting" on page 92.

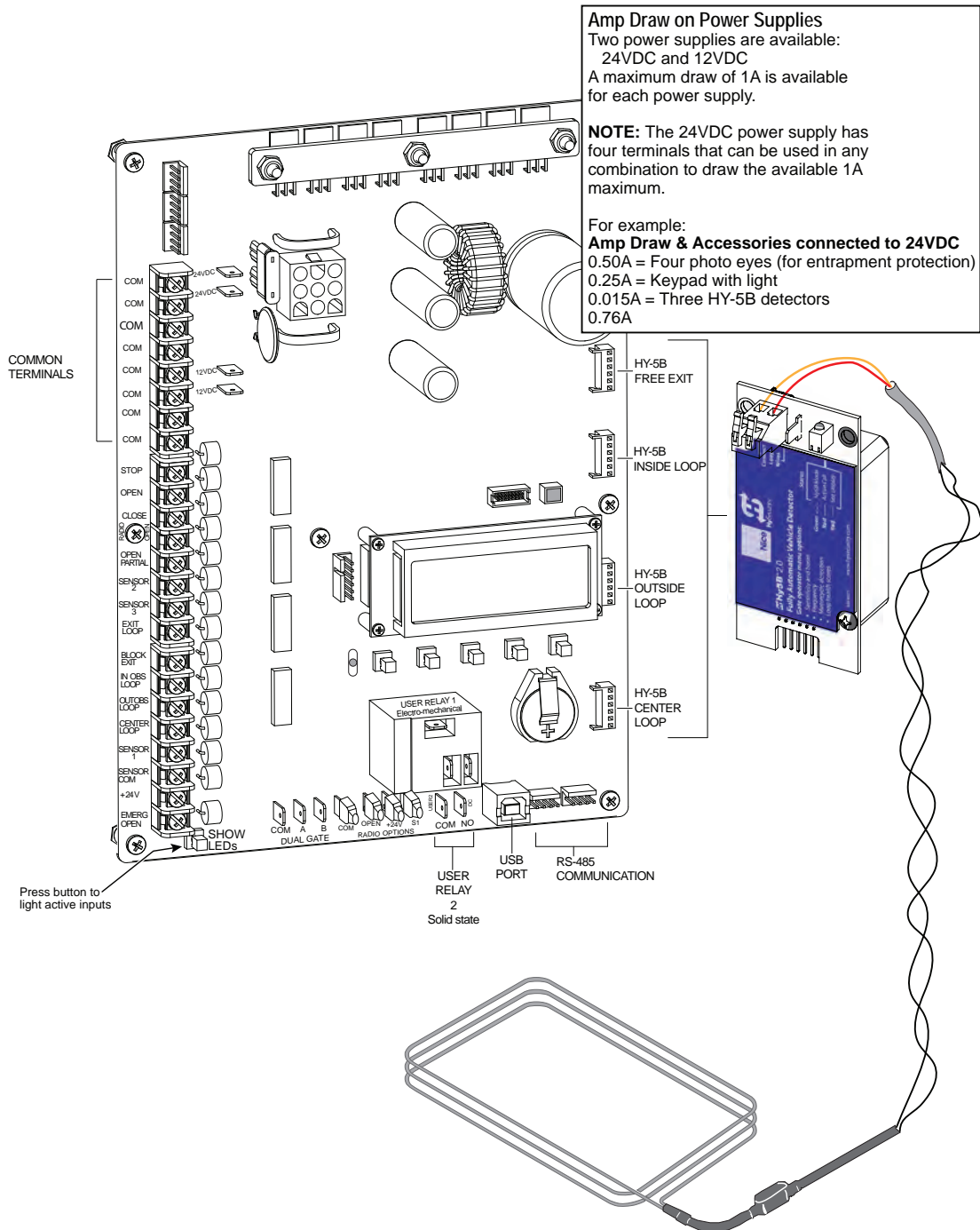

Figure 51. Smart DC Controller

SMART DC CONTROLLER

All the control device inputs listed in Table 11 are shown as a single input. The second wire is connected to a Common Terminal Bus (1 - 8) on the Smart DC Controller board.

The Fire Department Open input is an exception and requires a +24VDC input as well as enabling through the Installer Menu. For convenience a +24VDC terminal is located next to the EMERG OPEN terminal. See Figure 51. Note that programming in the User or Installer Menu is required for most connections.

Table 11. Smart DC Controller Board Inputs

Term. No.	Label/Input	Wire Connection	Uses
1- 8	Common Terminal	All user inputs are energized when connected to common except Emergency Open. .	All inputs except Emergency Open
9	Stop push button*	Normally Closed (N.C.). input. Jumper to Common if not being used.	Line of sight, external stop button or 3-button station.
10	Open push button*	Normally Open (N.O.) input. Not for radio or remote access controls.	Line of sight, external open button or 3-button station.
11	Close button	N.O. input. Connection for a close push-button.	Line of sight, external close button or 3-button station.
12	Remote Open & Radio Control**	N.O. input. For radio/remote open device - Program to also Close in User Menu (RO 1).	Remote access control or radio controls
13	Partial Open	N.O. input. This input will cause the gate to open to the Partial Open position programmed in the Installer Menu (7-32ft).	Supervised access controls
14	Sensor 2	N.C. input. Connection of a Monitored External Entrapment sensor. Type of sensor used is programmable in Installer Menu (S2).	External entrapment sensors.
15	Sensor 3	N.C. input. Connection of a Monitored External Entrapment sensor. Type of sensor used is programmable in Installer Menu (S3).	External entrapment sensors.
16	Free Exit Vehicle Detector	N.O. input. Free Exit Vehicle Detector connection.	Vehicle detector, box type connections for free exit loop.
17	Block Free Exit vehicle detector or Close Timer	N.O. input. Free Exit is only disabled if Close Limit Switch is tripped. If the gate is partially opened, the Free Exit detector will trigger the gate to open fully. The input can be converted in the Installer Menu to alternately disable the Close Timer.	If gate is partially opened, Free Exit detector will trigger gate to open fully. Input can be converted in Installer Menu to alternately disable Close Timer.

Table 11. Smart DC Controller Board Inputs

Term. No.	Label/Input	Wire Connection	Uses
18	Inside Obstruction Vehicle Detector	N.O. input. Inside reversing loop.	Vehicle detector, box type connections inside reversing loop
19	Outside Obstruction Vehicle Detector	N.O. input. Outside reversing loop.	Vehicle detector, box type connections outside reversing loop
20	Center Loop (Shadow) Vehicle Detector	N.O. input. Shadow function used for swing gates or Reset Loop for barrier arms only. However, User Relay 20 can be used in combination with a detector to perform an "arming loop" or "annunciation loop" function because there is no associated gate control logic in a slide gate.	Vehicle detector, box type connections. Shadow function for swing gates, reset function for barrier arm gates.
21	Sensor 1	N.C. input. Connection of a Monitored Entrapment sensor. Type of sensor is programmable in the Installer Menu (S1)	External entrapment sensor connections.
22	Sensor Common	When External Entrapment Sensor common wires are connected to this terminal, the sensors are energized when AC Power is present. The devices are then checked for presence and correct operation when the open limit is reached.	This terminal is used to perform monitored entrapment check
23	+24V DC	Convenient 24VDC power for accessories or the Emergency Open input.	Convenient 24VDC power for photo eyes or Emergency Open input.
24	Emergency Open (Fire Dept. Open) ***	N.O. input.	Emergency Open must be enabled via Installer Menu. It is energized by connecting to +24V terminal above it. EMERG OPEN overrides photo eye & edge sensor commands.

*Do not connect an external control to STOP or OPEN inputs unless controls are located in clear view of entire gate area.

**Use RADIO OPEN input or RADIO OPTIONS spade connections for all out-of-sight controls, such as a telephone entry or radio operated controls.

***Fire Department Open control must be keyed or guarded so that it can only be used by authorized personnel.

VEHICLE DETECTOR INSTALLATION OPTIONS

The Smart DC Controller provides a feature-rich interface to four different vehicle detector inputs.

NOTICE

Standard box type 11 pin (24 Volt DC or 24 Volt AC) vehicle detectors may be connected in the traditional manner as described in Installing Standard 11-Pin Box Type Vehicle Detectors.

HySecurity's custom Hy5B mini-detector module (Figure 52) plugs directly into the Smart DC Controller board making field installation much faster plus providing a large performance benefit. The detector communicates with the Smart DC Controller microprocessor to achieve the following benefits over common box type detectors:

- Loop frequency is automatically set and monitored by the Smart DC Controller
- Very low power draw, which is important for maximum UPS capability during a power failure and for solar applications.
- Cross-talk between multiple loops is impossible.
- Best operating frequency for each loop is automatically selected.
- Loop frequency and call strength can be reported on the Smart DC Controller display.
- Loop malfunctions are reported and stored by the Smart DC Controller.
- Most detector or loop faults that can occur are reported and presented on the Smart DC Controller display.

It is not mandatory to use two separate detectors for inner and outer obstruction detection, but the benefits in using an additional detector provide second vehicle tailgating detection, loitering alert, and selectable nonreversing options.

Terminal Ground: Lightning protection
Optional connection:
Use where lightning strikes occur.

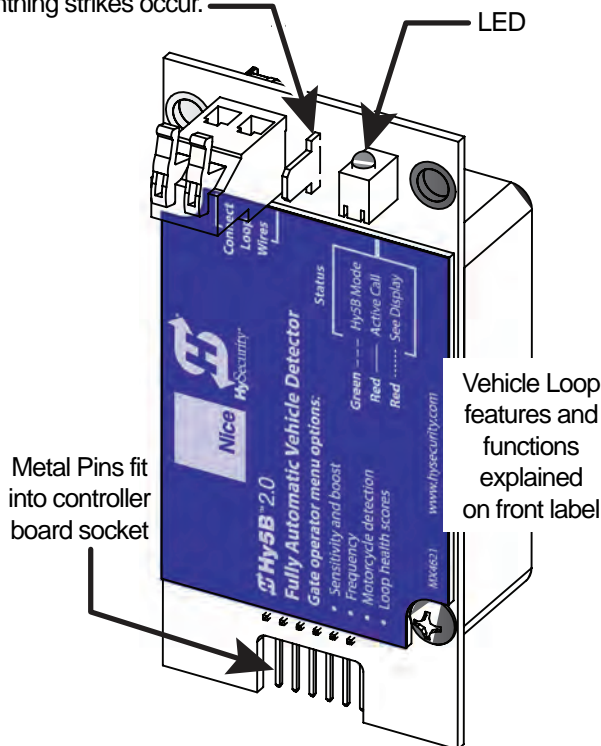

STANDOFF SUPPORTS
(INSERT INTO THE HOLES
IN THE CONTROL BOX)

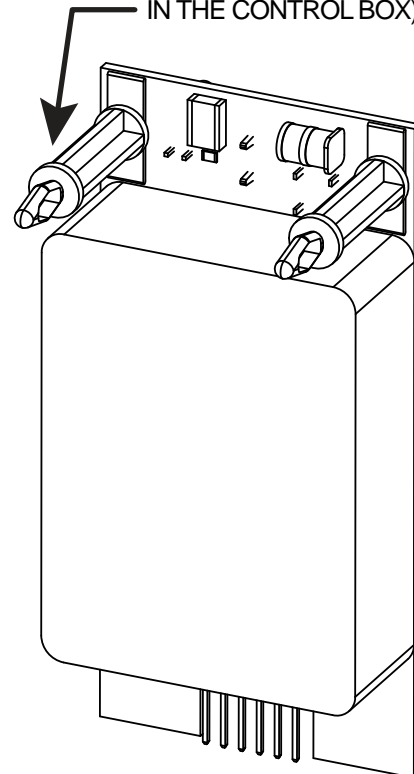

Figure 52. Hy5B Front and Rear Module

There are four vehicle detector inputs available on the Smart DC Controller:

- Free Exit Loop Detector - This opens a fully closed gate or reopens a closing gate.
- Outside Obstruction Loop Detector (Out Obs Loop) - Reversing loop on public side
- Inside Obstruction Loop Detector (In Obs Loop) - Reversing loop on secure side
- Center Loop Detector - Not used for slide gates.

NOTICE

Standard box type 11 pin (24 Volt DC or 24 Volt AC) vehicle detectors may be connected in the traditional manner as described in Installing Standard 11-Pin Box Type Vehicle Detectors.

CONNECTING HY5B VEHICLE DETECTORS

Install the Hy5B Vehicle Detector modules according to the following procedure:

1. Turn off both AC and DC power switches.
2. Insert the locking end of the two white plastic standoffs into the mounting holes on the detector.
3. Plug the detector into the appropriate socket along the right edge of the Smart DC Controller board. **Be careful to align the six detector pins into the socket correctly** (the screws for tightening the terminals should face toward the board), and then snap the standoffs into the holes in the control box.
4. Route the loop wires through the holes provided in the control box and connect the loop leads to the two terminals on the Hy5B detector. Tighten the terminal screws securely.
5. Repeat Steps 1 through 3 for each Hy5B detector.

6. To enable the detectors, turn on power. The detectors will immediately tune if they are connected to loops. Make sure no cars or other metal objects are over the loops.
7. If the detector module is unplugged after it is enabled, a communications alert (ALERT 10) will be triggered; if the fault continues an error message, ERROR 3 "Detector Failed" is displayed.

NOTICE

If there is any detector fault, the gate operator functions as if the detector is triggered.

Pressing the RESET button:

- Clears any errors
 - Tunes the detectors on connected loops
 - Un-installs any detectors that have been removed
8. The Smart DC Controller automatically governs frequency selection for all Hy5B detector modules. This simplifies installation and guarantees that there is no cross-talk between multiple loops. The frequency can also be manually selected; if this is required, refer to "Table 10. Smart DC Controller - Installer Menu Functions" on page 54.
 9. Sensitivity adjustment is available for each Hy5B in the installer menu. Generally, sensitivity does not need to be increased unless the loop is large or there are multiple loops connected to one detector. The Hy5B sensitivity defaults to automatic.

NOTICE

Do not exceed more than 200 square feet (61 square meters) of loop area to one detector.

If required, adjust the sensitivity by accessing the ELD, OOLD, IOLD, or CLD menu items in the installer menu.

- A = Automatic,
- M = Motorcycle
- 0 = Low with boost (See NOTE.)
- 1 = Normal with boost (See NOTE.)
- 2 = High with boost (See NOTE.)
- 3 = X-High with boost (See NOTE.)
- 4 = Low without boost
- 5 = Normal without boost
- 6 = High without boost
- 7 = X-High without boost

NOTICE

A boost feature is applied for settings 0 through 3. Boost increases the sensitivity during a call and is useful for maintaining continuous detection if the signal becomes weak (such as with tractor-trailer trucks). Sensitivity settings 4 through 7 are the same as 0 through 3, but without the boost feature.

10. Vehicle detector functions are configurable through the Installer Menu as described in Table 12.

Table 12. Vehicle Detector - Configurable Functions

Display	Meaning	Installer Menu Setting Options (Bold - Default)
OR 1	Outside Obstruction loop detector function	0 = Pause closing only 1 = Enable reverse to full open.
IR 1	Inside Obstruction loop detector function	0 = Pause closing only 1 = Enable reverse to full open.
DL 1	Vehicle detector logic	1 = Standard (Close Timer does not begin counting until all loops have cleared) 2 = Quick close (Close Timer can count to zero, even while loops are active, so the gate will close as soon as the loops are clear) 3 = Forced time out (Close Timer is forced to zero when both the OOLD & IOLD are tripped simultaneously. Additionally, all other close inputs are memorized and the gate closes immediately when all open commands and vehicle detector inputs are clear. 4 = Full Anti-tailgate (In addition to the functions of 3, the gate stops during the opening cycle when both OOLD & IOLD are tripped simultaneously.). When the OOLD and IOLD loops are cleared, the gate closes immediately.

INSTALLING STANDARD 11-PIN BOX TYPE VEHICLE DETECTORS

NOTICE

If photo eyes are used to monitor vehicle traffic instead of loop detectors, connect the photo eyes using the same steps described below.

If standard 11-pin box type vehicle detectors are to be used, perform the following procedure.

1. If there is sufficient space, install the sockets in the control box; if not, then install them in a separate external housing. Figure 53 is for general reference only.

NOTICE

Carefully consider your peripheral connections. Any peripheral device required for safe gate operation should be attached 24VDC in case of an AC power outage. Additionally, box detectors with relays require five times more power than Hy5B detectors. UPS battery life will be extended if you use Hy5B detectors instead.

2. Connect 24 Volt power to the detector. Connect Pin No. 1 to a 24VDC terminal and Pin No. 2 to Common.
3. Connect output Pin No. 6 to the Common Bus and output Pin No. 5 to one of the four detector terminal inputs (depending upon the detector function required) on the Smart DC Controller.
4. If multiple detectors are used, route the power wires and common wire from socket to socket (daisy chaining) rather than individually running each wire to the same location. See Figure 53. The only wires that are separate are the output wire to the Smart DC Controller and the detector loop input wires.

NOTICE

Always keep the detector loop wires well twisted at all places beyond the area of the loop. The lead in portion should be twisted to the detector to help mitigate problems associated with electrical noise getting into the loop wires. The wires should then be encapsulated in the saw cut with a flexible loop sealant. Refer to "Installing Vehicle Detectors and Loops" on page 83

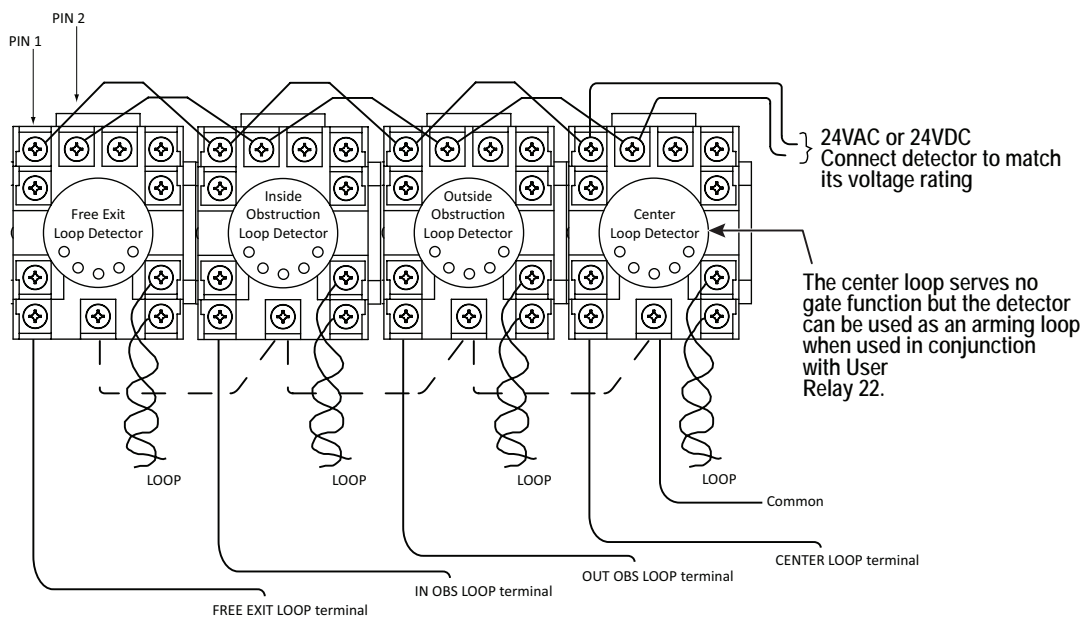

Figure 53. Standard 11-Pin Box Type Vehicle Detector

CONNECTING ACCESSORY DEVICES

Entrapment Sensor Connections

Devices, such as gate edge sensors and photoelectric beams, must be installed to protect against entrapment. These secondary external protection devices are required so the gate installation is in compliance with UL 325 Safety Standards. Figure 54 illustrates how to connect different sensors to the Smart DC Controller.

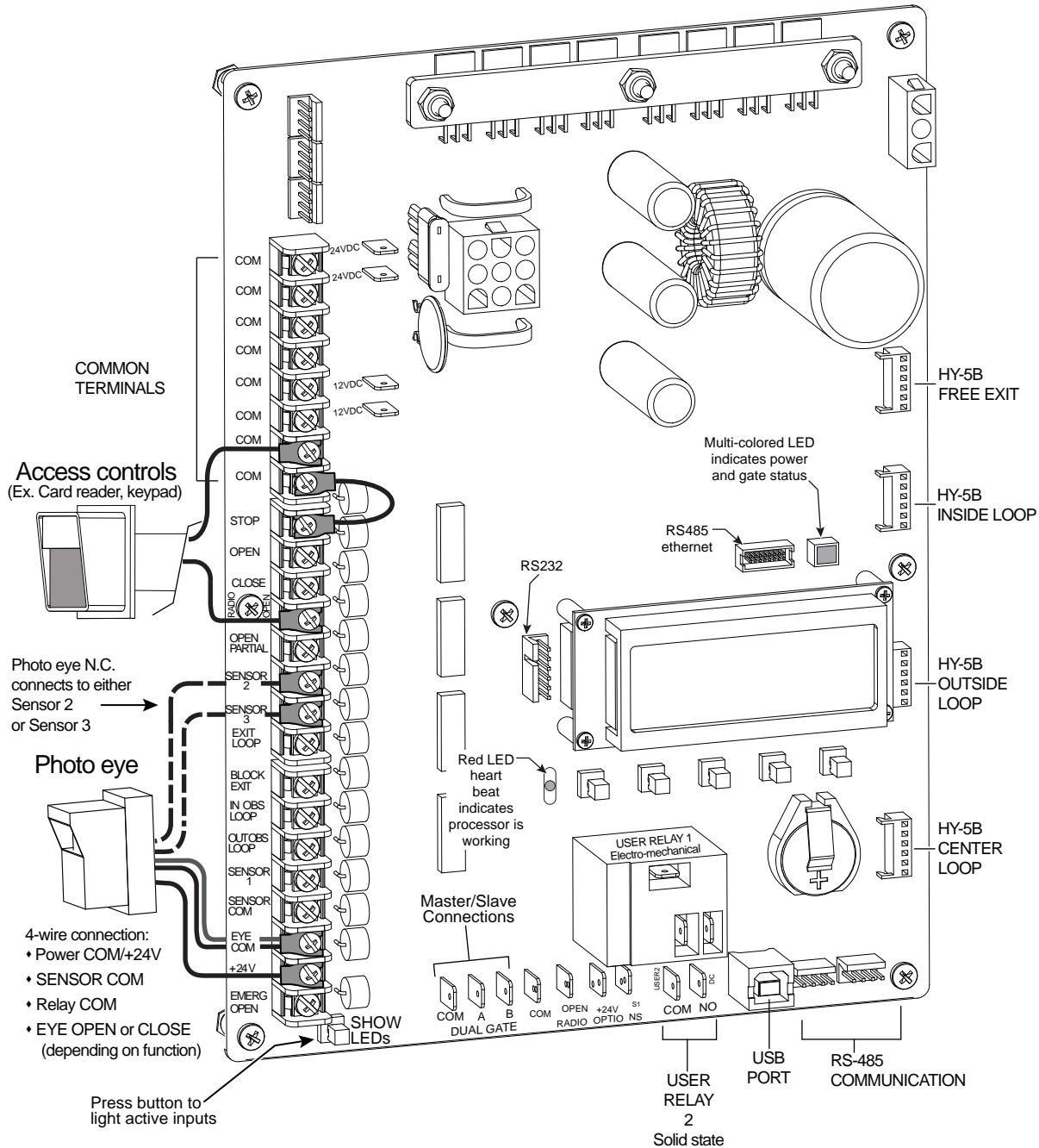

Figure 54. Entrapment Sensor Connections

MANUAL PUSH BUTTON STATION

A manual push button station controls the gate operator and opens, stops, and closes the gate. It is most often used by a guard in a 24-hour guard station. An example of the push button station connections on SlideSmart is shown in Figure 55.

⚠ CAUTION

Make sure the manual push button station is within site of the gate, a distance (six foot minimum) away from the gate's moving parts, and out of reach of children.

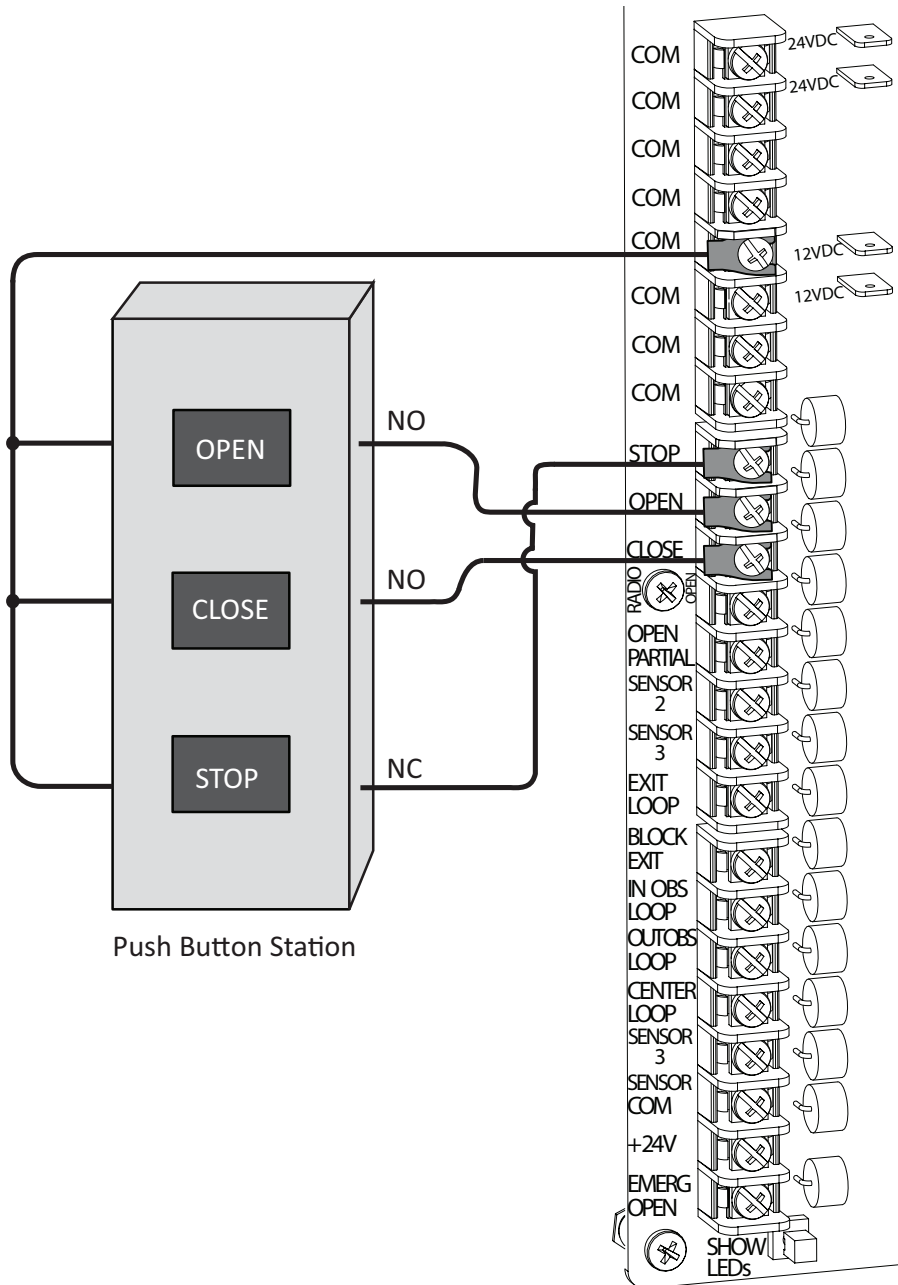

Figure 55. Manual Push Button Station Connection

USER RELAYS - PROGRAMMING PROCEDURE

The Smart DC Controller is able to interface with many types of external devices through the use of two user-programmable output relays. All of the user relay functions identified and described in Table 13 are accessible in the Installer Menu.

NOTICE

User Relays will operate normally to less than 18VDC. The USER 2 RELAY is rated for DC only up to 48V and does not have a N.C. (normally closed) connection.

Use the Smart DC Controller buttons to program the user relays according to the following steps:

1. Select and connect to the relay you wish to use on the Smart DC Controller board.
2. Access the Installer Menu and RL 1 or RL 2 display (depending on the relay you have connected).
3. Enter the appropriate function using the associated number (1 through 45) listed in the table.

Table 13. User-Programmable User Relays - Function Options

No.	Name	Description
1	Close limit output	Creates an interlock signal to another operator's interlock input, or simply to indicate that gate is secure or not. Relay is released when fully-closed limit switch is tripped. Relay is energized when fully-closed limit is released. (Any open command energizes relay.)
2	Close limit pulse output	Used in a sequenced system to command a second machine to close. Generates a brief pulsed output that occurs when close limit is triggered.
3	Open limit output	Indicates gate is at full-open position. Output becomes active when an open-limit is triggered and deactivates when open-limit is released or a close command is received. Use this output for a traffic light.
4	Open limit pulse output	Triggers a sequenced barrier arm gate operator to open. Generates a brief pulsed-output when open-limit is triggered. An additional pulse is also generated with any new open command even when gate is already fully-opened.
5	Warn before/during operate output	Controls an external warning device. This output is active whenever internal warn before operate buzzer is sounding but the relay output is constant on. Activation timing of this relay is controlled by setting User Menu for Warn Before Operate [bF].
6	Gate Lock output	Controls external solenoid locks or magnetic locks. In both directions of travel, this output is activated about 7/10ths of a second before operator starts moving the gate.
7	Gate forced open output	Activated if gate is forced off closed limit switch and operator is not able to restore gate to full closed position within four seconds. The buzzer resets itself in 30 seconds but relay stays active until gate receives a run command.

Table 13. User-Programmable User Relays - Function Options

No.	Name	Description
8	Gate open too long output	Activates when gate is open longer than the user-selected period of time. Adjustable from a 0 second to 135 seconds delay in 15-second increments. NOTE: TL - OPEN TIME ALERT adjustments can be made in Installer Menu.
9	Safety Mode Alert output	Activated when system is in Safety Mode or Entrapment Mode. Safety Mode occurs upon an impact with an obstruction. Entrapment Mode means gate is stopped and occurs if inherent entrapment sensor triggers while system is in Safety Mode.
10	Entrapment Mode Alert output	Activated only when system is in Entrapment Mode.
11	Unauthorized Vehicle Entry output	Activated when a second vehicle enters from outside without a valid input from an access control device. The OOLD and IOLD loops must be capable of being triggered at the same time for this relay to ever activate. This output releases when an access control input signals open or gate reaches the close limit position.
12	Outside Obstruction Vehicle Detector output	This output is active whenever Outside Obstruction Loop Detector is tripped. Interlocks an entry device to prevent pedestrian use.
13	Loitering Alert	Indicates vehicle is loitering on Outside Obstruction Loop with the gate closed. Adjustable from a 0 second to 135 second delay in 15-second intervals. NOTE: LT - LOITERING ALERT adjustments can be made in Installer Menu
14	Gate nearing full travel output	Activated when gate is approaching full open or full closed. Relay activates three feet from where software expects limit switch to be triggered whether moving toward full open, full close, or in a reverse travel mode.
15	Gate Failure output	Activated to report occurrence of problem. Indicates the system is in an Error, Fault, Alert, or Entrapment Mode. If active, gate is disabled.
16	Motor Running output	Active when motor is running and gate is in motion.
17	AC Power Failure output	This relay is normally energized and drops with loss of AC power.
18	DC Power Failure output	Activated when battery power is very low, but output ceases when battery is dead (18 volts). Relay is triggered when battery is less than 21 volts.
19	Flasher Relay	Controls flashing lights to pulse once per second. Relay is constantly pulsing except when open limit switch is triggered. Recommended to use User Relay 2 since it is an electronic switch
20	Free Exit Loop Vehicle Detector output	Active whenever Exit Loop is tripped.

Table 13. User-Programmable User Relays - Function Options

No.	Name	Description
21	Inside Obstruction Vehicle Detector output	Active whenever Inside Obstruction Vehicle Detector is tripped
22	Center Loop Detector output	Active whenever Center (Shadow) loop detector is tripped.
23	External Latching Gate Lock Output	Not functional in SmartDC operators.
24	Gate at Partial Open Position	Active when partial open position is reached or exceeded.
25	DC Power Alert	Active when on AC power or the battery voltage is above 21V. When used with User Relay 2, this option can shed electrical loads to conserve battery energy.
26	Free Exit Loop Detector pulse	Outputs a 250ms pulse when the free exit vehicle detector is tripped.
27	Not Open (w/ AC power)	Activated when gate is not on open limit and AC power is present. Deactivated when AC power fails or gate is on open limit.
28	Flasher (w/ AC power)	Output identical to relay #19 and pulses relay 500 ms/sec when gate not on open limit and AC power is present. Deactivated when AC power fails or gate is on open limit.
29	Arm Entry Ticket Dispenser	Not functional in SlideSmart operator.
30	Arm Exit Ticket Dispenser	Not functional in SlideSmart operator.
31	Resert Ticket Dispenser Pulse	Not functional in SlideSmart operator.
32	Backoff Pulse	Not functional in SlideSmart operator.
33	Transient In Pulse	Not functional in SlideSmart operator.
34	Transient Out Pulse	Not functional in SlideSmart operator.
35	Tenant In Pulse	Not functional in SlideSmart operator.
36	Tenant Out Pulse	Not functional in SlideSmart operator.
37	Special In Pulse	Not functional in SlideSmart operator.
38	Special Out Pulse	Not functional in SlideSmart operator.
39	Unknown In Pulse	Not functional in SlideSmart operator.
40	Unknown Out Pulse	Not functional in SlideSmart operator.
41	Test Open Pulse	Output pulses five seconds after close limit is activated. Typically used for cycle testing.
42	Break-Away Switch Output	Activates when arm break-away switch is tripped.
43	Warn Before	Combination of relays #5 and #16.

Table 13. User-Programmable User Relays - Function Options

No.	Name	Description
44	Partial Open Limit Pulse	Pulses for 250ms when gate, commanded with Partial Open input, reaches Partial Open Limit, or, gate is past Partial Open Limit and Partial Open input is activated.
45	Outside Obstruction/ Arming Loop Detector	Activated when OOLD/OALD detector input tripped and gate closed. Used for testing purposes.

BI-PARTING GATE SYSTEMS

Configuring two operators to be a Primary and Secondary pair is easy with the Smart DC Controller. There is no need to order a special model or any adapters. The area of the board marked Dual Gate employs a 3-wire RS-485 serial port for communication between primary and secondary operators. See Figure 56.

POWER REQUIREMENTS

When installing a dual-operator system, the following must be adhered to:

- An electrical conduit for interconnecting wires must span between the two operators. The dual gate communication wires and any low voltage control wires must be installed in a conduit that is separate from the high voltage power wires. See Figure 57.
- Complete the installation of both operators as separate machines and verify that their basic functions are correct as solo operators before interconnecting them.

- External control inputs, vehicle detectors and entrapment protection sensors may be connected to either gate operator without regard to preference.
- Be sure both operators are running the same software version. The software version is available on the display by pressing the RESET button on the operator. The software version appears beneath the word HYSECURITY. Keep the most current software loaded. It is available at www.hysecurity.com. Make it part of your maintenance routine to check for software upgrades on a regular basis.
- Both operators can be connected to the same 20A circuit breaker in the main panel. The wire size affects operator performance. Use the following chart as a guideline to size wire for the given distance from the power source to BOTH operators.

Table 14. Power Requirements			
AC Power	14 gauge wire	12 gauge wire	10 gauge wire
One operator 115V	730 ft (223 m)	1200 ft (366 m)	1900 ft (579 m)
Two operators 115V	460 ft (140 m)	750 ft (228 m)	1160 ft (354 m)
One operator 230V	2095 ft (639 m)	3350 ft (1021 m)	5300 ft (1615 m)
Two operators 230V	1465 ft (446 m)	2350 ft (716 m)	3750 ft (1143 m)

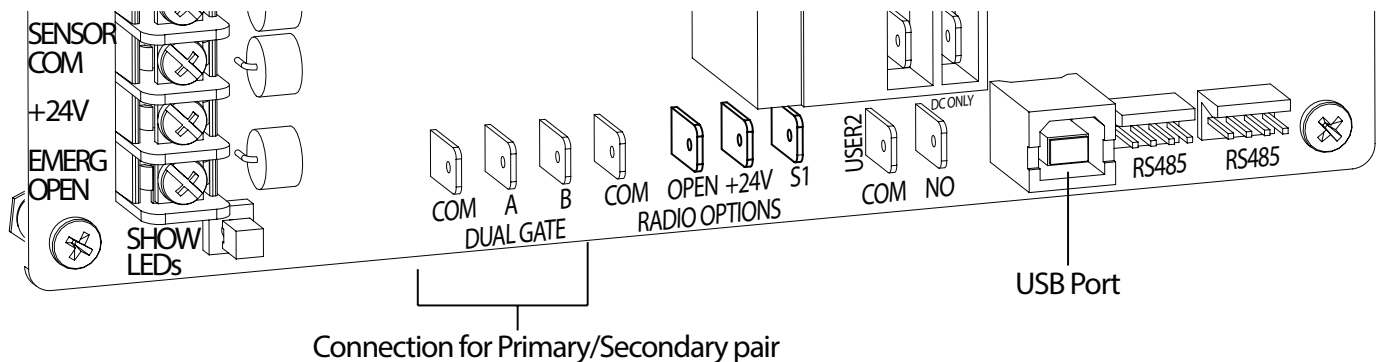

Figure 56. Primary-Secondary Pair

BI-PARTING GATE SYSTEMS

PRIMARY AND SECONDARY WIRING CONNECTIONS

1. As shown in Figure 57, connect a two-pair twisted, shielded communications cable to the DUAL GATE inputs in each unit. The inputs are located near the base of the Smart DC Controller. Be sure to connect the wires in pairs to the same terminal ports (A-A, B-B, and COM to COM) on both units. See Table 15.

2. Attach a ring terminal to the shield wire and connect it to the Smart DC Controller's convenient ground screw. Refer to Figure 57.

NOTICE

Connect the ground shield wire to only one operator, not both.

Table 15. Primary-Secondary Wiring

Primary	Secondary
A	A
COM	COM
B	B
* Only ground to one unit. Do NOT attach the shield wire to both units.	Shield wire to Ground*

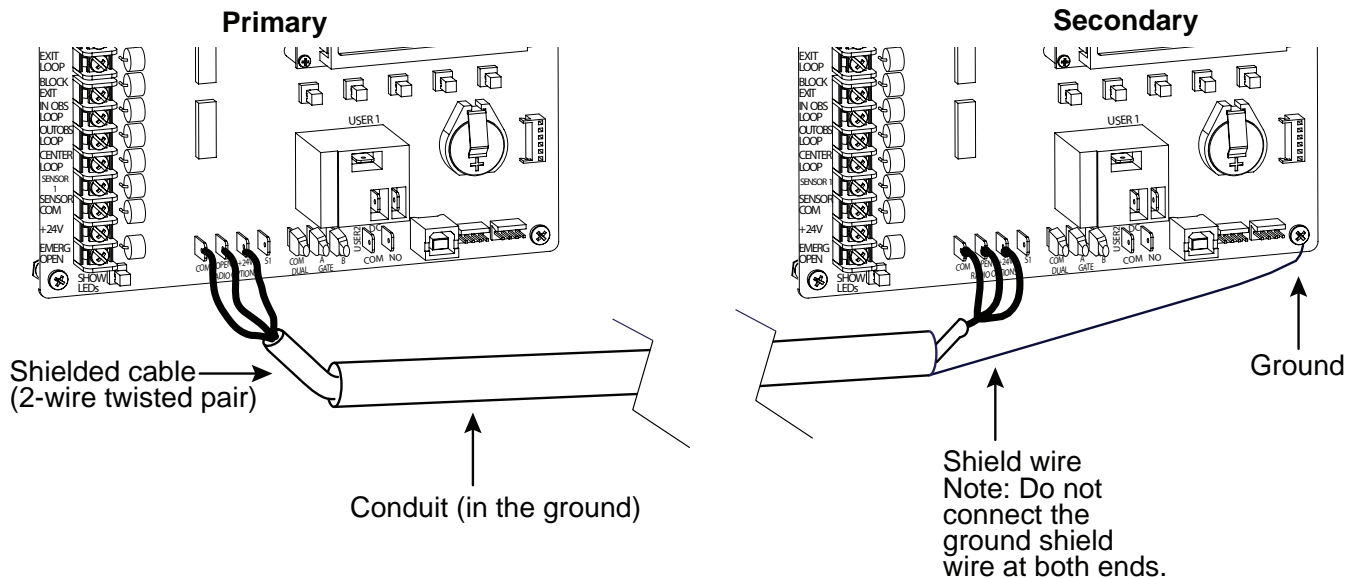

Figure 57. Primary-Secondary Pair Wiring Connections

NOTICE

Use a 2-pair, twisted, shielded cable with one pair of wires used to connect A-A and B-B terminals between the two boards. The other pair will connect the Common terminals. The shield should then be grounded on one end to one of the operators.

PRIMARY AND SECONDARY MENU SETUP

Determine which unit will be set up as the Primary. The other unit will be set up as the Secondary. It doesn't matter which unit is which, but you must identify the Primary and Secondary operators by taking the following steps and Figure 58:

Start by configuring the PRIMARY unit.

1. At a gate status display, press the MENU button twice. This accesses the User Menu and the CLOSE TIMER display appears.
2. Simultaneously, press the OPEN and RESET buttons to enter the Installer Menu. Release the buttons and the LEARN LIMITS display appears which is the first item in the Installer Menu.
3. Press NEXT until the DUAL GATE display appears. The factory default setting is 0.
4. Use the SELECT and NEXT buttons to navigate and change the setting to 2 PRIMARY.
5. To exit the Installer Menu, press the MENU button. A gate status appears in the display indicating you have returned to Run Mode.

NOTICE

For proper operation, you must set the other gate operator as SECONDARY.

6. Move to the other SlideSmart operator.
7. Using Smart DC Controller buttons, access DUAL GATE display through the Installer Menu.
8. Perform the same steps, 1 through 5, but address the operator as SECONDARY, setting 1.

When SlideSmart operator has been designated as the primary and the other as secondary, the dual-gate operators will be in constant communication, most often, in a peer-to-peer relationship. For example,

- Any control input that is attached to the secondary unit will be recognized by the primary once the Installer Menu is properly configured in both units.

- A diagnostics log is maintained in each unit, but both units run and store the errors codes and diagnostics pertinent to each other.
- The primary unit controls the close timer even if the timer is set in the slave unit. If a close timer is set in both units, the primary unit overrides the secondary setting.

NOTICE

If the dual-gate communication stops for whatever reason, (communication wire severed or the power switch is turned off in one unit), both operators cease to function and an ERROR 4 (Primary/Secondary Communication Error) appears in the display.



1. Start at a gate status display.



2. To access the User Menu, press the MENU button twice.



3. Access the Installer Menu, by simultaneously, pressing the OPEN and RESET buttons.



4. Use NEXT to navigate to the menu display. Change the setting using the SELECT and NEXT buttons.

Figure 58. Primary-Secondary Menu Setup

SENSOR AND ACCESSORY CONNECTIONS

This section of the manual provides information which may be useful when installing SlideSmart operators. It includes how to:

- Connect a Radio Receiver for Remote Open
- Install a Gate Locking Mechanism
- Install Vehicle Detectors and Loops
- Install Photoelectric Sensors
- Install Gate Edge Sensors
- Troubleshoot error codes, faults, and hardware issues
- Diagnose vehicle detector and loop faults
- Handle General Maintenance issues

CONNECTING A RADIO RECEIVER FOR REMOTE OPEN

Take the following steps to mount a commercial style 24VDC radio receiver (external antenna type):

1. Install the receiver in the chassis on either side of the control box.
2. Route the wires to the area marked RADIO OPTIONS. Only three wire connections are needed because the common wire and one radio output wire are connected together. Figure 59 shows additional wires from a two channel receiver.
3. Make sure to observe polarity and crimp together the black radio common wire and one of the radio output wires using a ¼-inch spade connector.
4. Fasten the two crimped wires to the COM terminal.
5. Connect the red wire to the +24V spade and connect the other radio output contact wire to the spade marked OPEN.

NOTICE

This terminal is the same as the input terminal labeled RADIO OPEN along the left edge of the Smart DC Controller.

6. Mount an external antenna onto the top of a fixed fence post near the operator.
7. Connect the antenna into the socket on the radio receiver.
8. Set the "DIP" switches in the receiver to match the same code used in the transmitter.

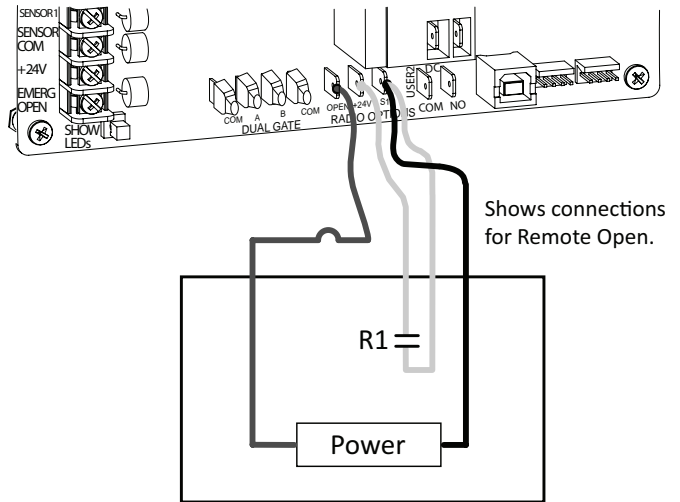

Two Channel Radio Receiver

Figure 59. Radio Receiver Connections

INSTALLING A MAGLOCK OR SOLENOID LOCK

To provide additional gate security, a maglock or a solenoid lock can be used and connected to the Smart DC Controller. The Smart DC Controller releases the lock prior to initiating gate movement. Before installing the lock, be sure to:

- Determine the electrical power requirements of your lock (maglock or solenoid lock). Electronic board and peripheral connections differ between high voltage and lower voltage gate operators.
- Determine the current required. Up to 1A is available from the 24VDC or 12VDC power supply. If the peripherals attached to the terminals need more than 1A, a separate power supply is required. Refer to "Overview of the Smart DC Controller" on page 65 and Figure 51.

SENSOR AND ACCESSORY CONNECTIONS

INSTALLING A LOCK FOR 12VDC OR 24VDC SYSTEMS

To install a lock for 12VDC or 24VDC systems, take the following steps:

1. Connect a wire between COM on USER 1 RELAY and a COM terminal on the Smart DC Controller board. See Figure 60.

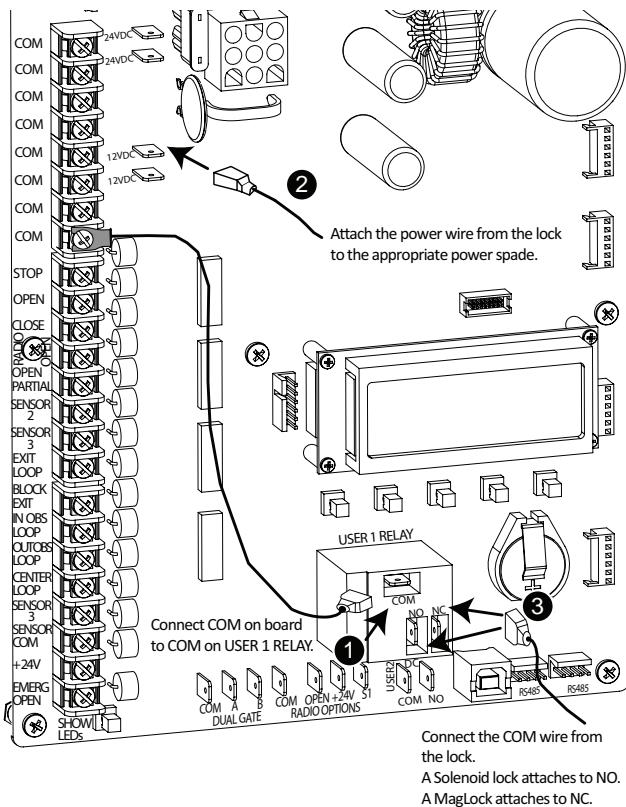

Figure 60. Lock Installation 12/24 VDC

2. Connect the power lead from the lock to the appropriate power spade (+24VDC or +12VDC)
3. Connect the common wire from the lock to NC on USER 1 RELAY if it is a maglock or NO if it is a solenoid.
4. Set the User Relay function in the Installer Menu to RL1 - 6. See Figure 62.

INSTALLING A LOCK FOR HIGH VOLTAGE SYSTEMS

To install a lock on higher voltage systems (115V or 230V), take the following steps:

1. Connect one lead of the power supply to one lead of the lock's coil. See Figure 61.

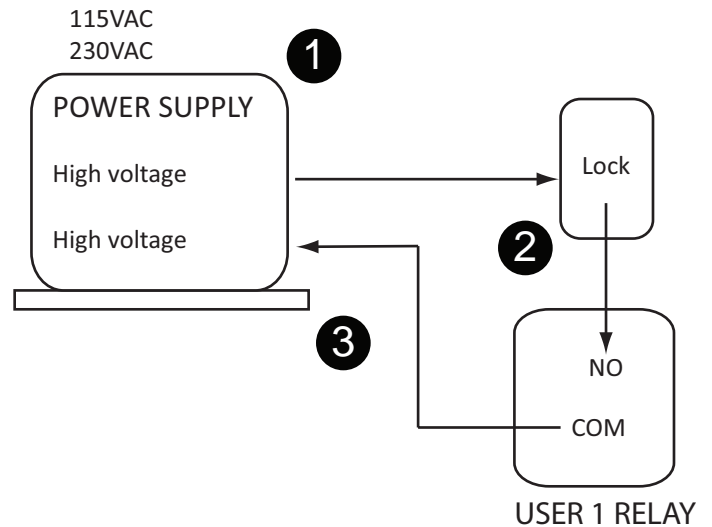

Figure 61. Lock Installation- High Voltage

2. Connect the other lead of the lock's coil to NO on USER 1 RELAY.

NOTICE

Connect to NC on USER 1 RELAY if installing a maglock.

3. Connect the COM on USER 1 RELAY to the second lead wire in the power supply (115V or 230V).
4. Set the User Relay function in the Installer Menu to RL1 - 6. See Figure 62.

SENSOR AND ACCESSORY CONNECTIONS



1. Start at a gate status display.



2. To access the User Menu, press the MENU button twice.



3. Access the Installer Menu, by simultaneously, pressing the OPEN and RESET buttons.

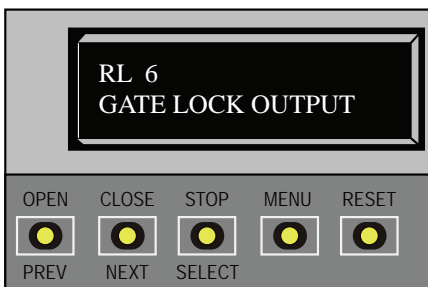

4. Use NEXT to navigate to the menu display. Change the setting using the SELECT and NEXT buttons.

Figure 62. Setting the User Relay Function in the Installer Menu

INSTALLING VEHICLE DETECTORS AND LOOPS

A vehicle detector passes a small current flow through the "loop" which then becomes an inductive coil. When a vehicle passes over the loop, the detector senses resultant drop in inductance and actuates detector output.

Loop Configurations:

Configurations differ depending on application. In parking applications, a loop may be as small as 4 x 6 ft (122 x 183cm). In traffic applications employing one of our swing or slide gate operators, the smallest loop should not be less than 6 x 6 ft (183 x 183cm) in order to detect high bed vehicles.

Rules to Follow for Security Gate Applications:

Side of the loop closest to the gate must be located at least 4 ft from the line of travel.

1. Shortest side of loop should be between 6 and 8 feet (1.8m and 2.4m) in length. Longest side of loop should be between 6 and 20 feet (1.8m and 6.1m) in length. For applications that need to span a wide area, use several smaller loops. Do not connect more than 200 square feet (18.6sq. m) of loop area to a single detector.
2. In applications with multiple loops, keep each loop at least 6 ft (1.8m) apart. This avoids "cross talk". It is possible to have loops closer together by selecting different frequencies. An advantage of using HySecurity model Hy5B detectors is that problematic "cross talk" is not possible.
3. For greater sensitivity and less chance of false calls caused by the motion of the gate, it is better to use multiple smaller loops, connected in a series circuit, to one detector instead of a single large loop.
4. To avoid interference, keep loops at least 2-inches (5cm) above any reinforcing steel. Do not route loop wires with, or in close proximity to, any other conductors, including other loop leads, unless shielded lead-in cable is used. Never route high voltage circuits in PVC conduit near a loop.

SENSOR AND ACCESSORY CONNECTIONS

5. Loop and lead-in wire should be one continuous piece. Avoid splices, if possible. If a splice is necessary for any reason, "pot" the splice in epoxy or use heat shrink to ensure that the quality of the splice covering is the same as the original wire jacket.
6. Use only 14, 16, or 18 gauge stranded wire with a direct burial jacket. Cross linked polyethylene insulation types, such as, XLPE or XHHW, will last much longer and are less prone to damage during installation than conventional insulation types. Preformed loops can be used before road surfacing or under pavers.
7. Twist loose tails of lead-in wires tightly, approximately ten times per foot. See Figure 63.
8. Follow this guide for the correct number of turns in the loop; 12 to 20 sq. ft = 5 turns; 20 to 60 sq. ft. = 4 turns; 60 to 240 sq. ft. = 3 turns; 3.7 to 6.1sq. m = 5 turns; 6.1 to 18.3 sq. m = 4 turns; 18.3 to 73.1sq. m = 3 turns

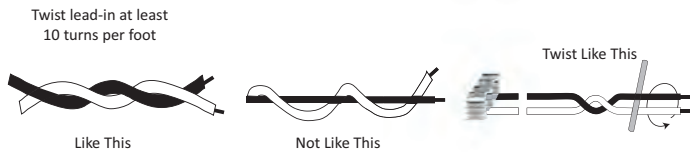

Figure 63. Wire Twist Lead-ins

9. This guide is written from a design perspective, but installation workmanship practices are equally important to insure proper operation and long loop life. The best way to insure a quality installation is to employ a professional installer experienced with detector loops. A few important practices are: See Figure 64.
 - The slot in the surface of the road should be cut ¼-inch wide x 1½-inch deep (6.3mm x 38.1mm).
 - The corners of the cut must be at an angle or core drilled to relieve stress on the wires.
 - After the wire is installed, the slot must be completely backfilled with a non-hardening sealer. If the loop wires are able to move in the slot after the sealer has set, the detector may give false calls.

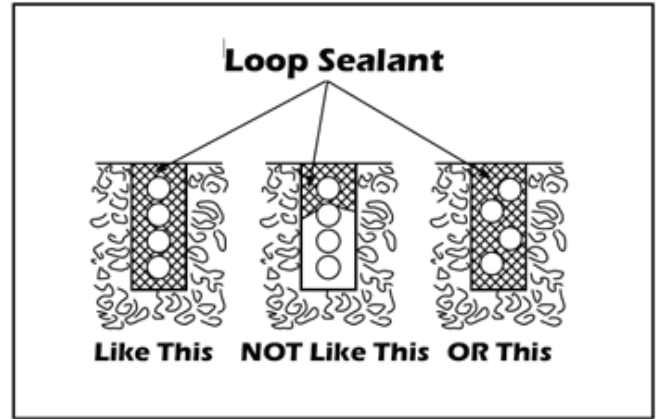

Figure 64. Loop Sealant

Detector Logic

HySecurity recommends that vehicle detectors be used for free open and obstruction sensing logic only. Because of their slower speeds, closing logic is a poor choice for security gate systems. Since there are several ways that the gate may be left standing open and because there is a loss of safety, our circuit has not been designed to accommodate "detect to close" logic.

Loop Diagnostics

The following tests cannot guarantee a functioning loop, but failure of either test means that the loop is definitely suspect, even though it may still be functioning at the time.

1. Test the resistance of the loop and lead-in wire. It should not exceed 4 Ohms.
2. Test the resistance between the loop and earth ground with a 500V Megohm meter. It should be 100 Megohms or more. Loops may function at 100 Megohms or less but will not be reliable (e.g. when the ground is wet from rainfall). Low resistance indicates broken or moisture saturated insulation. This is common if inappropriate wire insulation has been used.

A schematic for a slide gate loop layout is shown in Figure 65.

SENSOR AND ACCESSORY CONNECTIONS

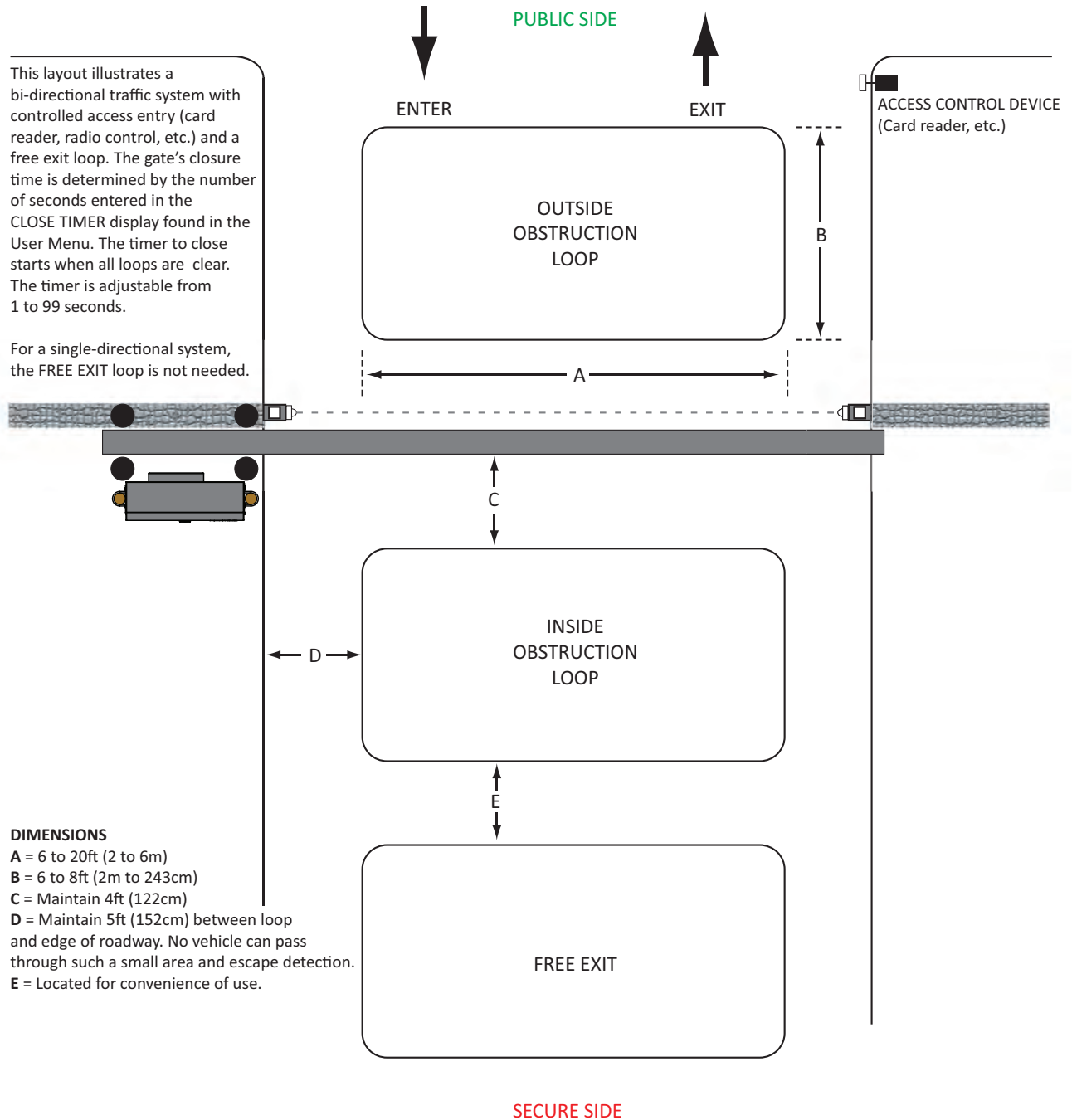

Figure 65. Vehicle Detectors and Loop Layouts for Slide Gates

SENSOR AND ACCESSORY CONNECTIONS

MONITORED EXTERNAL ENTRAPMENT SENSORS

As of January 2016, UL325 standard requires gate operators to monitor the presence of all external entrapment sensors, including non-contact (Photo Eyes) and contact (Edge) sensors. For operators built between January 1st, 2016 and July 31st, 2018 only one external entrapment sensor is needed to allow automatic operation, but all potential entrapment zones must be protected or eliminated. After July 31st, 2018, all Slide gate operators will need a minimum of 2 external entrapment sensors (1 open direction and 1 close direction) installed before automatic operation is allowed, but all potential entrapment zones must be protected or eliminated.

HySecurity monitors all external entrapment sensors connections by looking for NC contacts connected to input terminals. Smart touch software cycles power to device and looks for a time delay from when device powers on to when the contact closes (sensor input pulled low, meaning the sensor is not blocked/tripped).

Three programmable sensor inputs are available for use and must be programmed to a non-zero number when initial configuration is performed. The three inputs are labeled Sensor 1, Sensor 2, and Sensor 3 and are configurable in the installer menu (S1, S2, or S3) for the following options:

- 1 – Not Used
- 2 – Eye Close
- 3 – Edge Close
- 4 – Eye Open
- 5 – Edge Open
- 6 – Edge Both (Swing Only)
- 7 – Eye Both (Solo Slide Only)

It is the installers responsibility to determine the number of potential entrapment zones that exist and program the Sensor inputs according to which type of external entrapment sensor will be used to protect each zone. If more than three potential entrapment zones exist, then site design may be adjusted to eliminate risks or a Miller Edge MIM-62 may be used to connect additional sensors.

Potential entrapment zones on a slide gate are shown in Figure 66 Included in the drawing are examples of potential external entrapment sensor mounting/installation locations.

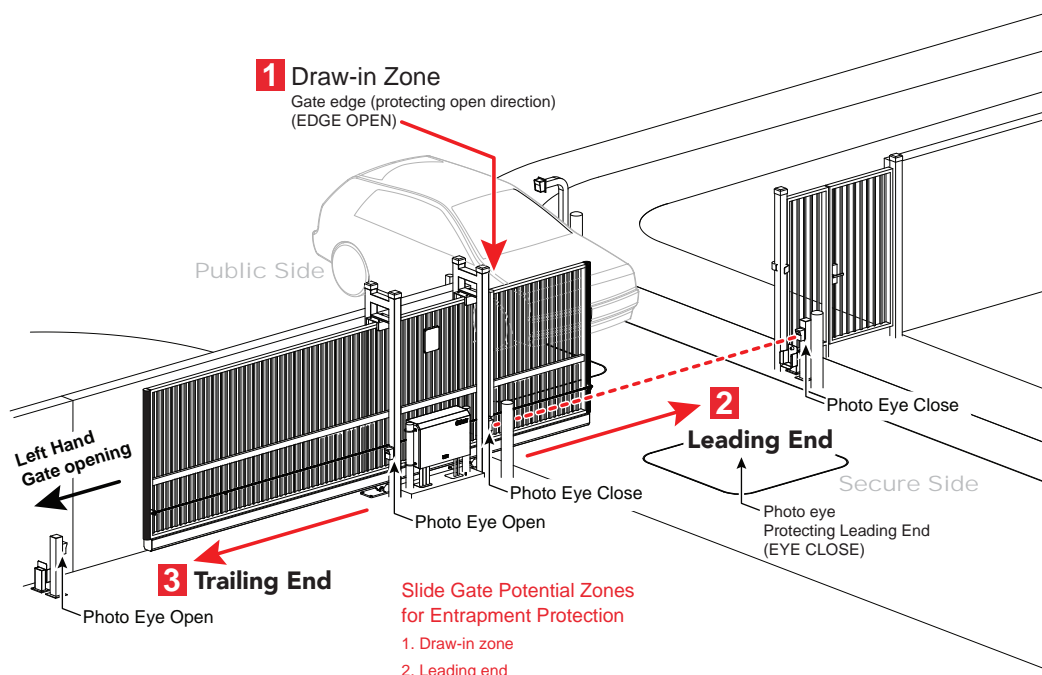

Figure 66. Site Overview

SENSOR AND ACCESSORY CONNECTIONS

After programming the sensor inputs in the installer menu or during initial startup, the appropriate type and number of sensors will need to be connected. Figure 67 below shows the wiring and dip switch settings of an EMX-MON photo eye (typical thru-beam wiring). A retroreflective photo eye will be similar and only have wiring similar to the receiver of the thru-beam photo eye.



All external entrapment protection sensors must be NC sensor outputs and wired to the SENSOR COM terminal for monitoring and powering purposes. The sensor becomes actively powered when the gate operator's motor runs.



Connect all contact and non-contact sensors to same power source. Example, Do NOT connect photo eyes to +24VDC and gate edges to +12VDC. Incompatible electricity flow. A FAULT 2 will appear.



Set DIP Switches
 1 = OFF
 2 = OFF
 3 = OFF
 4 = ON

NOTE: DIP switches must be set as shown otherwise the photo eye will not operate correctly.

Jumper POWER INPUT - 24V to COM in Receiver

**EMX IRB MON
 Photo Eye
 Receiver**



RED → +24V
 BLACK → COMMON / NEG. to SENSOR COM
 WHITE → NC RELAY to SENSOR 1

**EMX IRB MON
 Photo Eye
 Transmitter**



RED → +24V
 BLACK → COMMON / NEG. to SENSOR COM



DIP switches must be set as shown otherwise the photo eye will not operate correctly. If you receive an Alert, "ACTION BLOCKED" "Photo Eye Open" PEO or "Photo Eye Close" PEC, take steps to align the photo eye.

Figure 67. EMX-MON Photo Eye Wiring

An Edge Sensor can be either hardwired through an adapter module (Hy2NC) or a wireless transmitter/receiver combo (WEL-200 or iGAZE RE). Figure 68 below shows the wiring and dip switch settings of a WEL-200. For more information and wiring diagrams of other recommended sensors see the "HySecurity External Entrapment Sensor Wiring Guide".

EMX WEL-200 Wireless Edge Receiver
 Dip Switch Settings determine which relay activates when the associated edge is tripped.

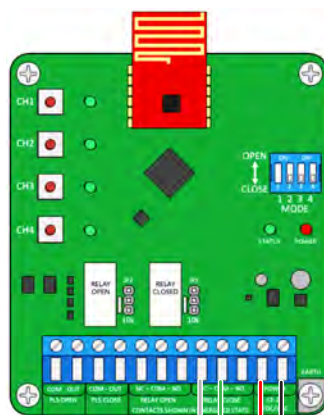

SENSOR 1,2, or 3 ←
 SENSOR COM ← +24V
 SENSOR COM →

Figure 68. WEL-200 or iGAZE RE

SENSOR AND ACCESSORY CONNECTIONS

EXTERNAL ENTRAPMENT PROTECTION

Consult a photoelectric sensor manual for wiring details. Make all electrical connections to Smart DC Controller as shown in Figure 69.

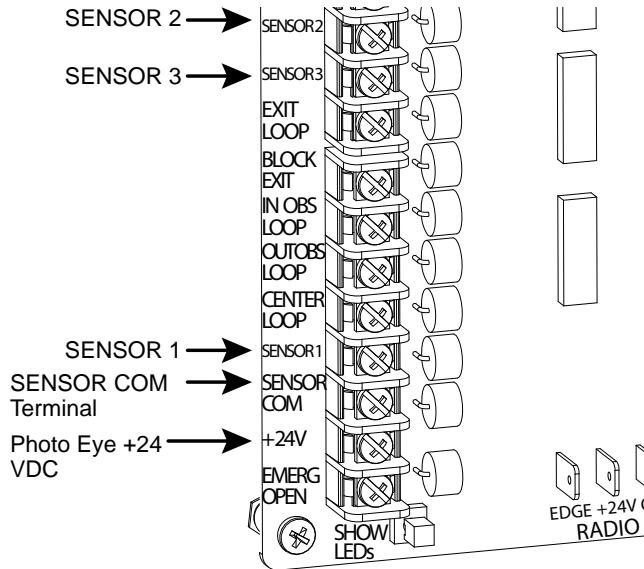

Figure 69. Entrapment Protection Only Connections

PHOTO EYE INSTALLATION TIPS

Underwriters Laboratories requires that any non-contact sensor used as an external entrapment protection device, must be tested to, and recognized by, the UL 325 Standard.

- There are two common types of photoelectric sensors, thru-beam and retro-reflective, and each has its advantages.
 - A thru-beam sensor is generally more powerful and able to function reliably with dirty optics and in poor weather.
 - A retro-reflective sensor does not require the installation and extra wiring of a separate emitter and receiver as is required in a thru-beam system, but retro-reflective eyes are generally more problematic in poor weather. Avoid using retro-reflective devices across outdoor distances greater than 24 ft (7.3m) because of performance and reliability issues.

- For pedestrian detection, mount thru-beam type photo eyes approximately 15" to 30" (4.6 to 9m) above the ground and as close to the gate as possible. A minimum of one photo eyes is required, but two is recommended, one photo eye to guard the open direction and the other for the close direction of travel, unless gate edges for entrapment protection are installed.
- Three wires to the receiver and two wires to the emitter are all that is required.
 - Depending on how the photo eyes are to be wired, +24VDC or +12VDC, power is provided via spades located just to the right of the COM terminal strip near the left side of the board.
 - The receiver and emitter common wires are connected to the SENSOR COM terminal at the bottom, left of the Smart DC Controller.
 - The photo eye NO or NC output wires connect to the Smart DC Controller at the Appropriate Sensor Input (1, 2, or 3). The appropriate sensor input must be programmed for Eye Open or Eye Close based on whether it spans the road or the "catch" area of an opening gate.
- If tripped while in motion, the standard function is to stop the gate and automatically restart again if the photo eye is clear within five seconds. An optional setting in the Installer Menu will cause a two second reversal of travel, or, if closing, can be programmed to reverse to full open.

NOTICE

Sensor Common & +24V is the recommended way to connect monitored photo eyes to Smart DC Controller.

NOTICE

If photo eyes are to be used for vehicle detection and logically function the same as a vehicle detector, connect the common wires to the COM terminals on the left side of the board and wire the NO output contact to the appropriate vehicle detector input: EXIT LOOP, IN OBS LOOP, and OUT OBS LOOP.

SENSOR AND ACCESSORY CONNECTIONS

If the photo eye has an internal switch for setting Light Operate vs. Dark Operate, select Light Operate. If the photo eye has a relay output and has both NO and NC terminals, some experimentation may be required to determine the proper connection. This is because, in the Light Operate mode, the output relay is normally energized and releases when the beam is blocked. Some manufacturers label an output as NO, when it is actually an NC contact. If the photo eye has a solid-state output you must choose a sinking type connection.

PHOTO EYE FUNCTION:

A tripped photo eye will prevent the gate from starting in either direction if the gate is stationary. If tripped while in motion, the standard function is to stop the gate motion and then automatically restart again if the photo eye is clear within five seconds. An optional setting in the Installer Menu will cause a two second reversal of travel.

Alignment:

Most photo eyes require careful optical alignment in order to aim the emitter beam to the center of the receiver or reflector. In order to avoid false triggering, it is important to carefully align the system, especially with retroreflective photo eyes. The best way to assure true centering of the beam is with some trial testing where the emitter is shifted to move the beam left and right and up and down until the range of the invisible cone of the infrared beam is known. Photo eyes usually provide alignment aid LED's for this setup, but they can be hard to see. HySecurity has provided a unique feature that turns power on to the photo eyes and causes the buzzer to chirp when the photo eyes enter and exit alignment. See "Table 9. Smart DC Controller - User Menu Functions" on page 44 to enable this feature. Set the menu item PE - PHOTO EYE ALIGN from a 0 to a 1. The buzzer chirps once when the emitter and photo eye receiver are not aligned. When the emitter and receiver are aligned, the buzzer chirps twice. If they go out of alignment again, the buzzer will chirp once. This "alignment mode" will automatically reset to 0 the next time the Close Limit Switch is triggered or the RESET key is pressed.

Notes about retro-reflective systems:

Correct installation and alignment of a retro-reflective photo eye and its reflector is important for trouble free performance. Any system operating at a range greater than 16 feet is more prone to false triggering due to dirty optics, condensation or poor weather. If care is taken in the initial mounting and alignment of the 3-inch reflector, the chance of problems is greatly reduced.

Taking steps to protect the photo eye and the reflector from being exposed to fog and being absolutely certain the photo eye is perfectly aligned will greatly reduce any false triggering of the system. The ideal mounting of a retro-reflective photo eye is inside an enclosure.

The ideal reflector mounting suspends it inside a 12-inch long piece of 3-inch PVC conduit. Cut the opening of the PVC conduit at a 45-degree angle to act as a drip shield. Hold the reflector against the backside of the PVC conduit by attaching a 3-inch male connector. Do not cement the connector. This would prevent the reflector from being reached for future cleaning. To create a mounting base, attach a 3-inch aluminum flange (electric meter hub) to the connector. This whole package can be mounted to any flat surface.

Locate the reflector in the center of the invisible beam of infrared light to achieve the most sensitive alignment. The beam center is determined by the following test: while holding the reflector in your hand, slowly raise it until the beam is no longer returned and the photo eye trips. Mark this maximum height. Now lower your hand and determine the lower limit of the infrared beam by watching for the trip point. Mark this position as well. Repeat the same procedure for left and right at the center elevation of the beam, as determined by the previous test. Once the four limits have been determined, either mount the reflector in the center of the area outlined or realign the eye for the position of the reflector. If photo eye is realigned, be sure to perform centering test again to verify that the reflector is truly in the center.

SENSOR AND ACCESSORY CONNECTIONS

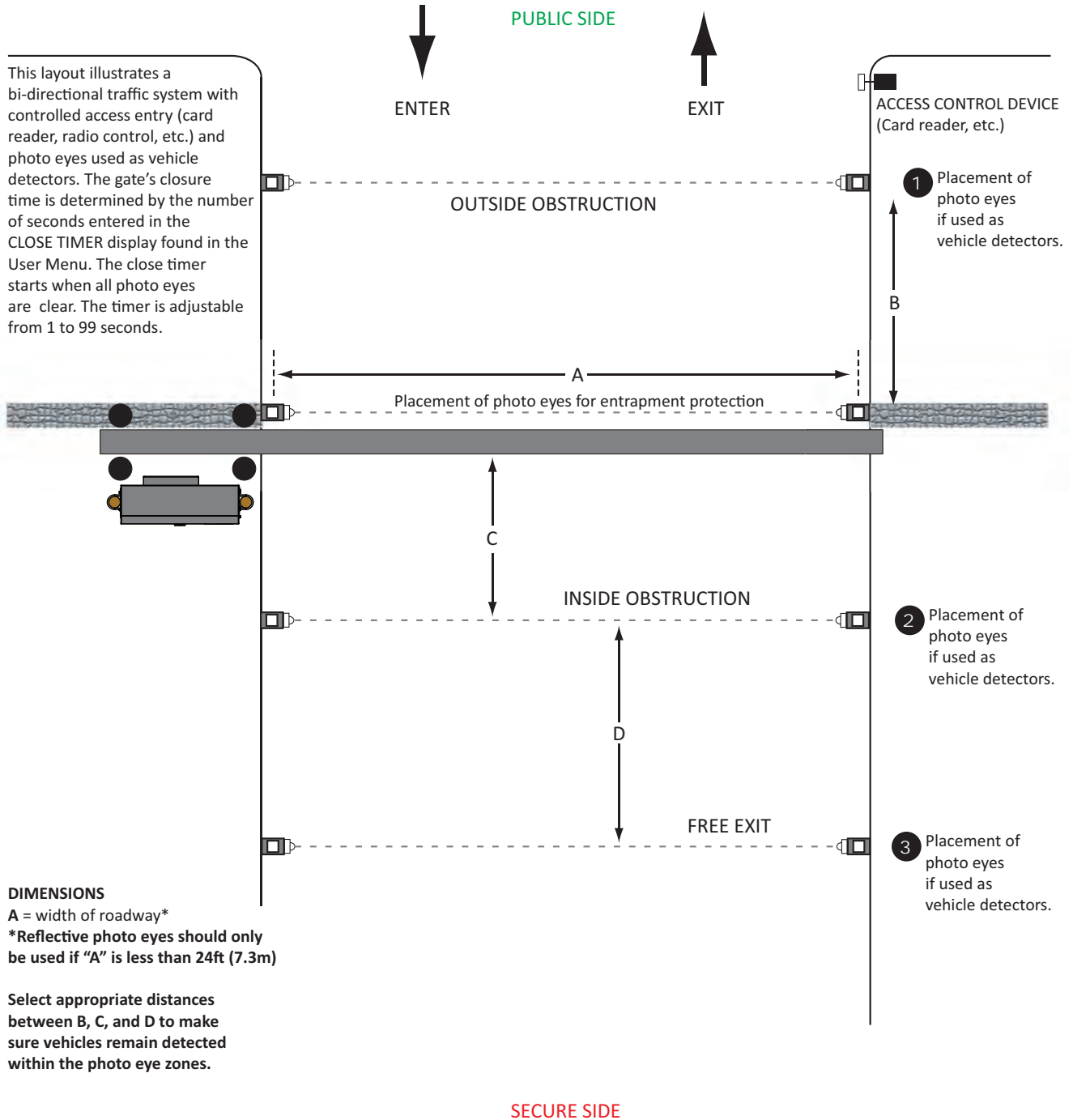

Figure 70. Photo Eye Placement when used as Vehicle Detectors

SENSOR AND ACCESSORY CONNECTIONS

EDGE SENSOR INSTALLATION TIPS

Refer to Figure 66 to help plan the most appropriate placement of the edge sensors being installed.

- If edge sensors are used sliding gates, one or more contact sensors (edge sensors) must be located at the leading edge, trailing edge and post-mounted both inside and outside of the sliding gate.
 - Three-sided detectors are ideal for slide gates.
 - If the clearance of the gate is 6" (15cm) or more above the road, then an edge sensor must be mounted on the bottom edge.
 - If gate is sliding open to a wall with less than 16" (41cm) of clearance, mount an edge sensor to wall that aligns with gate in open position.
 - Always route leads from edge sensors to gate operator so that they are protected from physical damage.
 - Underwriters Laboratories requires that any contact sensor used as an external entrapment protection device, must be laboratory tested to, and recognized to the UL 325 Standard.
- To monitor edge sensors, there must be a terminating resistor embedded in the edge. This resistor is typically 8.2K or 10K and always has a small current draw to confirm that it is installed.
- HySecurity gate operators must see a NC contact for monitoring purposes, therefore any edge sensor with a terminating resistor will need an interfacing device to convert the resistor output into a NC contact.
 - Types of devices that will convert the resistor output to NC output include the Hy2NC, and the WEL-200.
 - Hy2NC enables the Edge Sensor to be hard wired to the board.
 - The WEL-200 and is a wireless transmitter/receiver kit that communicates the state of the Edge Sensor wirelessly from the gate mounted transmitter to the operator mounted receiver.
- Hard-wired edge sensor adaptors (like Hy2NC) have inputs for up to two resistor terminated edges and up to two NC contact outputs.
 - HySecurity suggests the use of hard-wired edge sensor adaptors with an edge mounted to lead fence post to protect draw-in entrapment zone when the gate is running.
- Wireless transmitters are always monitoring for presence of resistor terminated edge(s) connected to it. Status of edge is then continuously communicated back to receiver which determines when to switch NC contact to NO and tell board edge is tripped or missing.
 - Receiver can only give a NC (edge not tripped) signal or a NO (edge tripped or missing) signal to control board.
 - If edge is tripped, missing, or resistor value is too low, transmitter will communicate this information to receiver which will indicate this to control board as a tripped edge (NC contact opens).
 - Additionally, if communication between transmitter and receiver is ever lost or corrupted, due to too much RF "noise" in area, then the receiver will indicate to control board that the edge is tripped, even if edge is present and functioning normally with transmitter.
- When selecting a wireless edge as one of the external entrapment sensors, be aware of the environment around it and know that RF interference from outside sources can drastically diminish range and performance of wireless device.
 - Airports, police stations, fire departments, hospitals, and other sites with a lot of radio traffic have shown to have a lot of RF noise in frequencies that most transmitter/receiver kits function.
 - Install transmitter in a way that it is in direct line of site with receiver's antenna throughout gate motion.
 - Limit distance between transmitter(s) and receiver(s) to what is specified by manufacturer, and be aware that range may be greatly diminished when operating in a noisy RF environment.

SMART DC CONTROLLER TROUBLESHOOTING

This section is available to help you troubleshoot any problems that may occur with SlideSmart operator. It provides information about Smart DC Controller display codes.

The Smart DC Controller system includes many self diagnostics. Specific messages appear on LCD and Audio Alert buzzer sounds distinctive chirps. Any alerts, faults or errors are also logged into memory and date/time stamped. For diagnostic purposes these messages can be retrieved with optional START software available from HySecurity. Refer to "Smart Touch Analyze and Retrieve Tool" on page 106.

Table 17 provides solutions to error codes, faults, and alerts that may appear on Smart DC Controller display.

Table 16. Smart DC Controller - Troubleshooting			
Display Condition	Description Alert, Error or Fault	Possible Causes	Solutions
SAFE MODE	Safe Mode Alert	Occurs when either edge sensor or Inherent Entrapment Sensor (IES) has been tripped. In Safe Mode, automatic close timer is disabled, but any command will reset and/or start gate in motion. Safe Mode clears when full travel is reached or RESET button is pressed. Gate binding, wind, a faulty edge sensor, or worn motor brushes can cause a false alert.	<ol style="list-style-type: none"> 1. Remove obstruction. 2. Adjust IES sensitivity. 3. Correct gate hardware. 4. Correct faulty edge sensor. 5. Check for worn motor brushes and replace, if necessary.
ENTRAPMENT MODE	Entrapment Mode Alert	<p>Occurs when IES is tripped when gate is already in Safe Mode. Operator will not function until it is reset, which can occur by:</p> <ul style="list-style-type: none"> ● An Open or Stop command from a push-button control ● Pressing black button on operator side ● Pressing RESET button below display <p>With any one of these inputs, operator will return to Safe Mode. Gate binding or wind can cause a false alert.</p>	<ol style="list-style-type: none"> 1. Remove obstruction. 2. Adjust IES sensitivity. 3. Correct gate hardware.

Table 16. Smart DC Controller - Troubleshooting

Display Condition	Description Alert, Error or Fault	Possible Causes	Solutions
NO AC POWER	No AC Input Power Advisory only.	AC power is shut off at source (breaker) or is not connected. AC power switch on operator (lower rocker switch) is turned off, or circuit breaker on the operator has tripped.	<ol style="list-style-type: none"> 1. Turn AC power switch on or connect power to operator. 2. Reset operator circuit breaker or connect power to AC switch. 3. Reset circuit breaker at electrical panel. 4. Have a licensed electrician check wiring.
LOW 24VDC	Low 24VDC UPS Batteries Advisory only.	Occurs when battery voltage has dropped to less than 22V. At this level, batteries are 80% depleted. Normal function until 21V.	<ol style="list-style-type: none"> 1. No AC Power. See above item. 2. Wiring / Connector problem - check all connections. Clean or repair as required. 3. Check battery condition. 4. Smart DC Controller charger failure - check charger voltage and replace Smart DC Controller. 5. Transformer failure - replace transformer.

Table 16. Smart DC Controller - Troubleshooting

Display Condition	Description Alert, Error or Fault	Possible Causes	Solutions
DEAD BATTERY	Extremely low UPS batteries – no automatic operation - batteries below 21V.	Occurs when battery voltage has dropped to less than 21V. At this level, batteries are 90% depleted. Gate will automatically open or close depending upon setting chosen. Refer to AP - AC LOSS "User Menu" on page 40. No additional automatic function is possible, but limited push button control is available to 18V.	<ol style="list-style-type: none"> 1. No AC Power. See above item. 2. Wiring / Connector problem - check all connections. Clean or repair as required. 3. Check battery condition. 4. Smart DC Controller charger failure - check charger voltage and replace Smart DC Controller. 5. Transformer failure - replace Transformer.
HYSECURITY BAD POWER	Critically low 24V supply power. This message can occur only on initial start up if power is critically low.	DC power is below 14V – no control functions will be allowed at all.	<ol style="list-style-type: none"> 1. No AC Power. See above item. 2. Wiring / Connector problem - check all connections. Clean or repair as required. 3. Check battery condition.
No display, LED blinking	Smart DC Controller is receiving power, but battery voltage is very low.	<p>Several possible causes:</p> <ul style="list-style-type: none"> ● AC power has been shut off from the operator for too long and the batteries are drained. ● Wiring problem. ● Batteries no longer hold a charge. ● Bad Smart DC Controller. ● Bad transformer. 	<ol style="list-style-type: none"> 1. No AC Power. See above item. 2. Wiring / Connector problem - check all connections. Clean or repair as required. 3. Check battery condition.

Table 16. Smart DC Controller - Troubleshooting

Display Condition	Description Alert, Error or Fault	Possible Causes	Solutions
HYSECURITY LOADER	Software is being loaded into Smart DC Controller.	Software is currently being loaded.	Wait for software to finish loading.
ALERT 1 FORCE OPEN	Gate forced open.	Gate has been forced open from a full close limit and is being prevented from re-closing.	Will self-clear after an open or close input.
ALERT 2 DRIFT CLOSED	Gate drifted closed.	Gate has drifted closed from a full open limit and is being prevented from re-opening.	Will self-clear after an open or close input.
ALERT 3 EXCESS DRIFT	Gate drift in transit - Advisory only	Alert appears if gate drifts three times in a five minute period.	Check track to make sure it is level.
ALERT 4 MOTOR OVERLOAD	Thermal overload alert. When alert is triggered, gate can only "fully open" until alert is cleared.	Motor drive heat sink exceeds 195°F. Alert will temporarily disable operator, but will automatically reset itself when it cools down. May also occur if the heatsink temperature is 70°F. higher than ambient temperature.	Check gate hardware, weight/length of gate. Alert automatically clears when temperature drops below threshold.
ALERT 5 BOTH LIM ACTIVE	Not used on SlideSmart.	N/A	N/A
ALERT 6 LIM NOT RELEASED	Not used on SlideSmart.	N/A	N/A
ALERT 7 FREQ SHIFT FAULT	Hy5B has detected a frequency change outside normal range.	Likely causes are poor integrity of loops or metallic objects within range. This message will also indicate which detector alert applies to: Exit Loop (ELD), Inside Obstruction Loop (IOLD), Outside Obstruction Loop (OOLD), or Center Loop (CLD) - (User Relay 22).	Loop lead in wires and roadway should be checked for problems or replaced.
ALERT 8 LOOP SHORTED	Hy5B has detected a loop shorted to ground.	Caused by inadequate insulation of loop wires.	Loop lead in wires and roadway should be checked for problems or replaced.
ALERT 9 LOOP OPEN	Hy5B has detected a lack of continuity in loop wire.	Caused by broken loop wire or wire has come unplugged from detector.	Loop and lead in wires should be checked for problems or replaced.

Table 16. Smart DC Controller - Troubleshooting

Display Condition	Description Alert, Error or Fault	Possible Causes	Solutions
ALERT 10 12C BUS ERROR	Smart DC Controller has detected a communication error with a Hy5B vehicle detector.	Caused by removal of Hy5B or lack of integrity of socket connection. This message will also indicate which detector alert applies to: Exit Loop (ELD), Inside Obstruction Loop (IOLD), Outside Obstruction Loop (OOLD), or Center Loop (CLD) - (User Relay 22).	Remove and re-install the Hy5B and press RESET. Replace Hy5B, if necessary.
ALERT 11 DETECTOR FAULT	Smart DC Controller has detected a problem within an Hy5B vehicle detector.	Caused by a fault within Hy5B. This message will also indicate which detector alert applies to: Exit Loop (ELD), Inside Obstruction Loop (IOLD), Outside Obstruction Loop (OOLD), or Center Loop (CLD) - (User Relay 22).	Remove and re-install the Hy5B and press RESET. Replace Hy5B, if necessary.
ALERT 12 ON TOO LONG	Smart DC Controller has an active loop input (Hy5B or box detector output) for more than 5 minutes.	Caused when Smart DC Controller sees an active loop for more than 5 minutes. "Active" loop can be actual or false. This message will also indicate which detector alert applies to: Exit Loop (ELD), Inside Obstruction Loop (IOLD), Outside Obstruction Loop (OOLD), or Center Loop (CLD) - (User Relay 22).	Check traffic patterns at site. Loop and lead in wires should be checked for problems or replaced.
ALERT 13 STIFF GATE	Smart DC Controller has detected a gate that, over time, has taken more power to move than it used to.	Caused by degrading gate hardware or debris in track. This alert appears in history log. It does not have any effect with regard to opening or closing gate.	Check and correct gate hardware as required.
ALERT 14 STUCK GATE	Smart DC Controller has detected that it cannot move gate at all.	Caused by broken gate hardware or ice/snow buildup.	Check and correct gate hardware as required.

Table 16. Smart DC Controller - Troubleshooting

Display Condition	Description Alert, Error or Fault	Possible Causes	Solutions
ALERT 15 NO TARGET	Target magnet on the chain is missing or has not been detected.	Target magnet fell off or target sensor wires are damaged.	<ol style="list-style-type: none"> 1. Make sure target is properly fastened to chain. 2. Check target sensor to make sure it is reading magnet. Change sensor if it or its wires are damaged.
ALERT 16 COM BUS ERROR	Smart DC Controller has detected an internal communications error.	Several possible causes: <ul style="list-style-type: none"> ● Excessive electrical noise. ● Lack of earth grounding. ● Internal problem on Smart DC Controller. 	<ol style="list-style-type: none"> 1. Determine and remedy source of electrical noise. 2. Install a ground rod. 3. Replace Smart DC Controller.
ALERT 17 BAD COIN BATTERY	Small battery on Smart DC Controller is loose or needs replacing.	Coin battery is loose or dead.	<ol style="list-style-type: none"> 1. Verify that battery is properly seated. 2. Replace coin battery. 3. Restore power. 4. Press RESET button.
ALERT 18 CHANGE BATTERY	Smart DC Controller has detected that 24VDC UPS batteries need to be replaced.	Batteries are not taking a charge properly.	Buzzer will chirp every minute until UPS batteries are replaced.
ALERT 19 FALSE SLOWDOWN	Not used in SlideSmart.	N/A	N/A
ALERT 20 LI BLOCK OPEN	Not used in SlideSmart.	N/A	N/A
FAULT 1 MOTOR RUN TIME	Should not occur in SlideSmart.	Maximum run timer fault.	Call Technical Support.
ALERT 21	Not used in SlideSmart.		

Table 16. Smart DC Controller - Troubleshooting

Display Condition	Description Alert, Error or Fault	Possible Causes	Solutions
ALERT 22 INTLOCK FAILURE	Interlock/ Sequential Gate communication lost	Appears when RS-485 communication connection is lost for more than 5s between interlocked (dual gate) or sequenced gate operators.	<ol style="list-style-type: none"> 1. Check cable connections and wiring. Make sure both operators are working properly and have same current and up-to-date software versions. Alert auto clears when communication between two operators is restored. 2. If operator on site is a solo gate operator and display code ALERT 22 appears, access Installer Menu. Verify Installer Menu items: DG (Dual Gate) and SG (Sequential Gate) are both set to zero.
ALERT 24 - EXTERNAL RELAY FAULT	Communication Lost with Hy8Relay module	Appears when R3-R10 is programmed to a non-zero number in the installer menu, but there is no Hy8Relay module communicating with the board.	If no module is used, reset R3-R10 to 0. If a module is used, ensure that all wiring is correct and the correct module is being used. The STC and SDC communicate at different rates with the module.
ALERT 25 HYPNET LOW BATTERY	Coin Cell Battery in HyNet is Low	Appears when a HyNet is connected and reports that the internal battery of the HyNet is low.	Replace the battery in the HyNet
ALERT 28 BATTERY DISCONNECTED	Battery Disconnected from Board	Dead or disconnected batteries detected by SDC board. Operator may still be functional if on AC power but will not have battery backup. Was Error 9 in pre-h5.57 software versions	Replace or reconnect batteries to the controller.

Table 16. Smart DC Controller - Troubleshooting

Display Condition	Description Alert, Error or Fault	Possible Causes	Solutions
FAULT 2 PHOTO EYE	Photo eye is missing or not working.	This fault can only occur if monitored photo eye check fails. See "Monitored External Entrapment Sensors" on page 86 for details.	Correct malfunctioning photo eye.
FAULT 3 VOLTAGE SAG	Not used in SlideSmart.	N/A	N/A
FAULT 4 GATE NO LOAD	Smart DC Controller has detected there is no load on operator. Gate is non-operational while this fault is triggered.	Possible causes: <ul style="list-style-type: none"> ● Motor wires disconnected. ● DC switch off. 	<ol style="list-style-type: none"> 1. Check DC motor wires. 2. Turn DC power switch on. 3. Press RESET to clear fault.
FAULT 5 LIMIT FAILED	Not used in SlideSmart.	N/A	N/A
FAULT 14 STUCK GATE	Smart DC Controller tries 3 times to overcome stuck gate. Gate is non-operational while this fault is triggered.	Caused by broken gate hardware or ice/snow buildup.	<ol style="list-style-type: none"> 1. Check and correct gate hardware as required. 2. Press RESET to clear fault.
ERROR 1 DIRECTION ERROR	Smart DC Controller detects operator ran in wrong direction.	Motor wiring.	<ol style="list-style-type: none"> 1. Check motor wiring and correct, as needed. 2. Press RESET to clear fault.
ERROR 3 Hy5B FAILED	Smart DC Controller detects communication error with a Hy5B vehicle detector.	Caused by Hy5B removal or lack socket connection integrity. Message indicates which detector alert applies to: Exit Loop (ELD), Inside Obstruction Loop (IOLD), Outside Obstruction Loop (OOLD), or Center Loop (CLD).	<ol style="list-style-type: none"> 1. Press RESET. 2. Remove and re-install Hy5B. 3. Replace Hy5B, if needed.

Table 16. Smart DC Controller - Troubleshooting

Display Condition	Description Alert, Error or Fault	Possible Causes	Solutions
<p>ERROR 4 PRIMARY- SECONDARY COM</p>	<p>Smart DC Controller has detected a communication error between primary and secondary in a dual gate installation.</p>	<p>Several possible causes:</p> <ul style="list-style-type: none"> ● Primary/Secondary communication cable has not been installed correctly. See Primary and Secondary Wiring Connections. ● Primary/Secondary not configured properly through Installer Menu. ● Operator not properly earth grounded. ● Primary/Secondary communication cable installed in same conduit as high-voltage AC power. ● One operator does not have power applied to it. ● One operator may have a different software version. 	<ol style="list-style-type: none"> 1. Correct communication cable. 2. Verify each operator is configured properly via Installer Menu. Set one operator as Primary, one as Secondary. 3. Install ground rod per NEC/NFPA standard. 4. Install separate communication cables conduit. 5. Ensure AC power is present at both operators and all power switches are ON. 6. Check software version currently loaded in operator by pressing RESET. Make sure both operators are running same software version.
<p>ERROR 5 No display</p>	<p>Display provides no indication of this error, but it can appear in START log and means that Smart DC Controller has detected a serious internal error.</p>	<p>Internal software/hardware error. Report any instance of this error to HySecurity Technical Support.</p>	<ol style="list-style-type: none"> 1. Turn both switches off to reset software. 2. Update to latest software version using START. 3. Replace Smart DC Controller.

Table 16. Smart DC Controller - Troubleshooting

Display Condition	Description Alert, Error or Fault	Possible Causes	Solutions
ERROR 6 STC-VFD COMM ERR	Not used in SlideSmart.	N/A	N/A
ERROR 7 MENU CHECKSUM	Software issue exists that may require factory reset.	Corrupt software or data.	Call HySecurity Technical Support for assistance.
ERROR 8 RPM SENSOR	RPM sensor disconnected.	Motor Encoder or wires are damaged or unplugged.	Check wiring from motor to Smart DC Controller board.
ERROR 9 BATTERY DISCONN	Smart DC Controller detects no battery connected.	Batteries are disconnected, or a wiring fault exists. SlideSmart operators ship with a wire disconnected to prevent battery drain. Replaced by Alert 28 in h5.57 software version.	<ol style="list-style-type: none"> 1. Ensure red wire in upper left corner of control box is connected to switch. 2. Correct any issues with battery wiring. 3. Check 35 amp fuse on circuit board.
ERROR 10 SLOWDOWN SWITCH	Not used in SlideSmart.	N/A	N/A

VEHICLE DETECTOR AND LOOP FAULT DIAGNOSTICS

If HySecurity Hy5B vehicle detector modules are used, the Smart DC Controller has the ability to store and report detector and loop fault information for performance diagnostics.

If the Smart DC Controller senses a loop or detector problem:

- The LCD display flashes the name of the affected detector or error and the appropriate alert code.
- The buzzer chirps continuously at regular intervals until the issue is resolved.

Table 17. Hy5B Vehicle Detector Faults and Errors

Alert or Error #	LCD Description	Advisory	Resolution
ALERT 7	FREQ SHIFT FAULT	Hy5B vehicle detector - Abnormal frequency change alert.	Alert indicates an unstable loop frequency. Check loop and lead in wires for problems. Replace them, if necessary.
ALERT 8	LOOP SHORTENED	Hy5B vehicle detector - Loop is shorted.	Alert indicates that loop and lead in wires are shorting out. Check wires for problems. Replace them, if necessary.
ALERT 9	LOOP OPEN	Hy5B vehicle detector - Disconnected loop alert.	Alert indicates loop wires are loose or disconnected. Check wires for problems. Replace them, if necessary.
ALERT 10	I2C BUS ERROR	Hy5B vehicle detector - Communications alert.	Alert indicates detector is not communicating properly with Smart DC Controller. Alert occurs if detector is unplugged or connection is unstable. If communication is not reestablished within 30 seconds, controller will reset and message changes to ERROR 3.
ALERT 11	DETECTOR FAULT	Hy5B vehicle detector - Malfunction alert.	Display indicates Hy5B detector malfunction. Check detector for problems. Replace it, if necessary.
ALERT 12	ON TOO LONG	Detector input triggered too long - More than five minutes.	Display indicates Hy5B detector malfunction. It alert also works for any input connected to terminal strip for standard box detectors. Check that a vehicle is not parked on loop. Also, determine if loop is stable. An unstable loop can hold detector in a triggered state.
ERROR 3	DETECTOR FAILED	Hy5B vehicle detector - Communication failed. Smart DC Controller will behave as if detector is triggered, usually holding gate fully open.	Alert indicates detector is not communicating properly with Smart DC Controller. Alert occurs if detector is unplugged or detector has failed. To replace detector, press RESET button to clear error and re-seat detector or install a new one.

Even if the loop problem self heals, historical data about detector/loop performance and a log of Alerts, Faults and Errors can be retrieved from the Smart DC Controller by downloading from the RS232 communications port or the USB port. HySecurity's free START software, a laptop computer, and a special download cable or USB cable are required to retrieve and read this data.

Loop Health:

The Hy5B monitors loop health which is comprised of loop noise, loop step changes and loop reference changes. Loop health readings accumulate throughout a 24 hour period and the accrued readings are posted to the Event Log each day at midnight. After midnight, the loop health baseline resets to its highest value of 777.

Example of an Event Log posting (Figure 71):

```
Event log:
02/09 EVENT - CLD Loop Health: noise 5, step 6, ref 7
```

Figure 71. Hy5B Event Log

Loop Presence:

Loop presence is dependent on "disturbance effect" of the entire vehicle. Presence determines how long to hold the "memory" of a stationary vehicle on a loop before it is forgotten and ignored. Set the presence of the loop:

- LONG (default) lasts about 20 hours dependent on call strength and sensitivity setting. The Hy5B tunes out the "disturbance effect" when a vehicle is stationary on a portion of the loop, but keeps the undisturbed (unaffected) portion of the loop operational.
- INFINITE never drops the call. The INFINITE setting requires a certain amount of signal strength. A "threshold" is maintained and it will hold the call forever. The loop connected to an Hy5B with this setting may become nonfunctioning.

Table 18. Setting Loop Presence		
Sub-menu Item	Display	Example Site Scenario
PR 0	(LONG)	With sensitivity set to A (AUTO) and a large sedan stationary on loop, LONG presence may hold call for many hours before vehicle's presence is tuned out. Then, stationary vehicle is ignored and unaffected portion of loop becomes operational. In contrast, with sensitivity set to M (MOTORCYCLE), default threshold only lasts about 1 hour before presence of motorcycle on loop is tuned out.
PR 1	(INFINITE)	A site where standing or parked vehicular traffic (on large area loops) is a daily or consistent basis, INFINITE presence setting is a viable option. When loop may have vehicles parked on it for more than several hours and it must hold the call, set presence to INFINITE.

NOTICE

Hy5B has ability to continue counting vehicles passing over loop even though a stationary vehicle may be on a portion of loop. Controller and Hy5B detector also exchange pertinent information, so if a power failure were to occur, controller can determine if a vehicle is on loop when power returns.

Frequency:

Knowing the exact frequency of a loop can be useful as a diagnostic tool, and verifying the stability of the loop frequency is valuable information. To view the actual loop frequency of a specific vehicle detector, go to the setting for that detector in the Installer Menu, switch the selection from 0 to 1, and press the Select button. The display will show the loop frequency. The frequency is usually between 20,000 to 80,000 Hertz.

Changing the Loop Frequency:

Hy5B detectors can never crosstalk. If for any reason, you want to manually change the loop frequency, change the Installer Menu option for the desired loop from 0 to 3, and then press the Select button. Each detector has a choice of four frequencies. Press the Select button when the desired frequency setting is found, and the controller will perform a reset and tune to the new frequency setting.

Call Strength Level:

Knowing the call strength of a detector is valuable because it provides information about how well the loop is actually “seeing” a specific vehicle. For example, it may be useful to check to see if the loop is easily detecting the middle of a high bed semi-truck. The strength of a detector call can be displayed in real time, on a scale of 0 to 7. As indicated in the table below, when the Installer Menu setting for a given detector is set to 2, and the Menu button is pressed, the LCD display will read Level 0 - 7 Call Level. If the call strength on the display appears as a level 4 or less, consider increasing the sensitivity level by adjusting the rotary switch on the Hy5B detector.

Table 19. Hy5B Vehicle Detector Call Level Display

Installer Menu	LCD Description	Setting Options (Bold = Factory Settings)
ELD 0	EXIT LOOP SET	0 = Run mode 1 = Show frequency 2 = Show call level 0-7 3 = Set Frequency 4 = Show Sensitivity 5 = Set Sensitivity 6 = Show Inductance 7 = Show Loop Health 8 = Set Presence
ILD 0	IN OBS LOOP SET	
OLD 0	OUT OBS LOOP SET	
CLD 0	CENTER LOOP SET (Can be used as an arming loop with User Relay 22.)	

SLIDSMART SCHEMATICS

Figure 72 illustrate the schematics for SlideSmart DC HD25 and SlideSmart DC HD30.

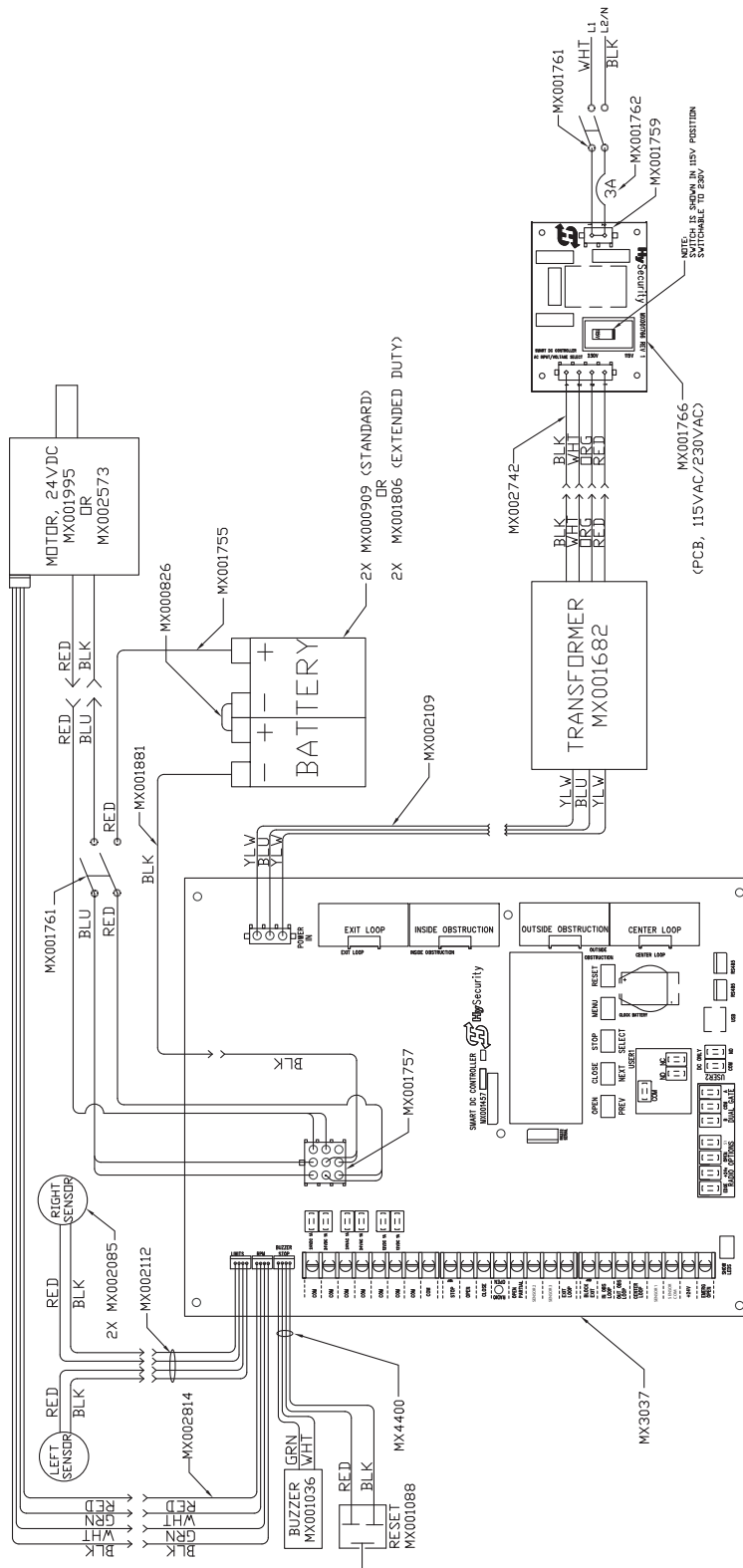

Figure 72. SlideSmart DC HD25 andHD30 Schematics

GENERAL MAINTENANCE

Smart Touch Analyze and Retrieve Tool

HySecurity provides Smart Touch Analyze and Retrieve Tool (START) software to help HySecurity gate operator users and installers conduct the following field service activities:

- Configure installer and user menu settings
- View the operator history (event) log
- Display monitored inputs for operator diagnostics
- Load Smart DC Controller (SDC) operator code

With START software loaded on your laptop computer, you have an invaluable management tool for all HySecurity operators. Either the USB port or the RS-232 serial port, found on the Smart DC Controller (see Figure 73), allows you to download system diagnostics and upload system configurations using the START software. The free START software is conveniently located on the www.hysecurity.com website. Instructions for downloading START are found on the website, as well.

What You Need

- Standard USB 2.0 A-B communications cable. If you are using the HySecurity RS-232 to USB adapter, be sure to install the USB driver in your laptop.
- Laptop computer with Windows PC operating system (XP, Vista, or Windows 7/8/8.1/10)
- Minimum 128MB of RAM
- Minimum 5MB of hard drive disk space
- VGA graphics card (minimum resolution of 800 x 600)

Installing START Software

Read the START User Manual, and then take the following steps to download START software:

1. Bring up your web browser and type in <http://www.hysecurity.com> in the command line.

2. Click Technical Support (left column) on the HySecurity home page.
3. Enter your user name and password. If you do not have a user name, register as an online member.
4. Click to Download: S.T.A.R.T. software for Smart Touch and Smart DC.
5. Read the End User License Agreement and, if you agree to the terms, click on, I accept (bottom of the page).
6. Click RUN. A setup window appears.

NOTICE

If the operating system on your laptop is VISTA or Windows 7, you must first disable the "User Account Control Settings," refer to the procedure in "Setting User Account Controls" on page 107 and then continue to step 9.

7. Follow the step-by-step instructions to complete the installation.
8. When the download is complete, log out of the HySecurity website. Shortcuts for the START and Smart DC Controller History Logs appear on your laptop's desktop.

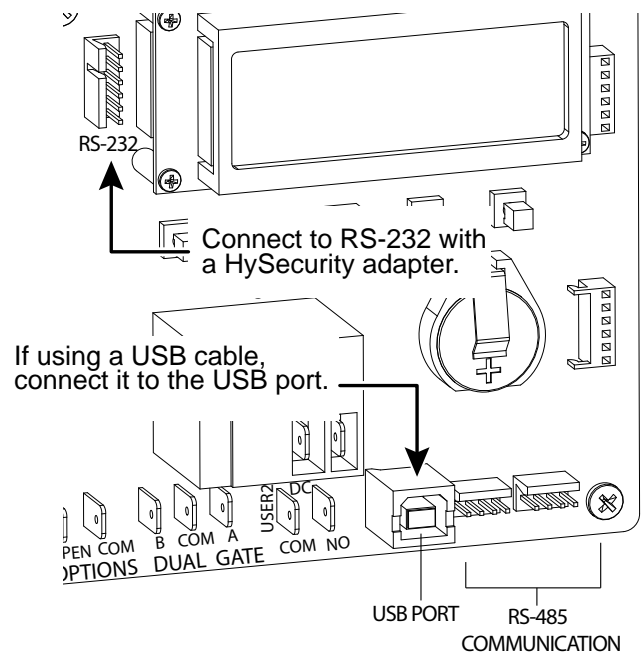

Figure 73. Smart DC Controller RS-232 and USB Connection

Setting User Account Controls

Because of the security settings inherent in VISTA and Windows 7, you need to disable the "user account controls" in the operating system before uploading START software onto your laptop. Take the following steps:

In Windows 7:

Go to Start Menu -> Control Panel -> User Accounts and Family Safety -> User Account -> Change User Account Control Settings "slide the slide bar to the lowest value (toward Never Notify), with description showing Never notify me -> Press Ok -> Reboot Computer.

In Vista:

Go to the Start Menu type "msconfig" and press Enter -> In System Configuration select the tools tab -> Scroll down till you find "Disable UAC" and single click it -> Press the Launch button -> Press the Apply button -> Press OK -> Reboot Computer.

ELECTRICAL CONTROLS

CAUTION

Before servicing, turn OFF all power switches.

No routine maintenance is needed for the electrical system or controls. If the environment is very sandy or dusty, or has many insects, be certain to seal all holes in the electrical enclosure. Blow the dust out of the electric panel with compressed air. Use "Smart DC Controller Troubleshooting" on page 92 to assess and fix error, alert, and fault codes. If it is necessary to call a distributor for assistance, be sure to have your model and serial number ready. Other helpful information includes the name of the job, approximate date of installation, and the service record of the operator.

MECHANICAL MAINTENANCE

CAUTION

Before checking internal mechanisms of operator, turn off all power switches.

SlideSmart mechanical maintenance is not in depth or difficult, but should be performed on a routine basis. Operator chassis is zinc plated, but some environments may speed corrosion of this plating.

Schedule regular maintenance and look for the following:

- Verify drive belt has proper tension. Check for drive belt wear. Fraying edges or missing teeth indicate that drive belt needs to be replaced. Refer to "Drive Belt Tension and Alignment" on page 108.
- Check for signs of rust. If any areas of rust are found, reduce spread of corrosion by treating areas with a rust inhibitor.
- Check motor. DC motors contain carbon brushes which wear over time and must be replaced. Failure to replace brushes will result in DC motor damage. Brushes should be inspected every year in high usage applications or every 100,000 cycles and replaced as needed.
- Replace worn-out batteries. Refer to "DC Battery Replacement" on page 109 and "Clock Battery Replacement" on page 110.

SOFTWARE MAINTENANCE

SDC board software is constantly being enhanced with new features that create an easier install and improve on board diagnostic tools. Check the HySecurity website for latest version of software before heading out for field maintenance.

Use S.T.A.R.T. software to download latest software version to a PC laptop and upload it to SlideSmart gate operator in the field.

NOTICE

If site includes a bi-parting gate system, make sure software version used in Primary and Secondary operators is identical.

DRIVE BELT TENSION AND ALIGNMENT

Proper drive belt tension is important for prolonging the life of the drive belt and maintaining the superior performance of the operator. To check the drive belt tension, take the following steps:

1. Remove the SlideSmart cover and protection plate.
2. Turn off the AC and DC power switch.
3. Check to make sure the pulley is aligned horizontally.
4. With your finger, apply light outward pressure to the drive belt. If it is properly tensioned, it should only move about 1/16 to 1/8-inch (1.6 to 3.2cm). See Figure 74 and Figure 75.
5. To replace or re-tension the drive belt. Loosen the four motor bracket nuts and move the motor accordingly.
6. Retighten the motor bracket nuts.
7. Replace the protection plate and SlideSmart cover.
8. Turn the AC and DC power switches ON. This cycles power which allows the operator to search for the target magnet and "relearn" its limits.
9. If you don't cycle the power, the operator will not "relearn" its limits to operate properly.

NOTICE

Be aware that the gate will cycle open and close (close or open) as it relearns its limits. See Resetting the OPEN and CLOSE Limits.

To adjust the tension or replace the belt, loosen 4 nuts and slide the motor bracket. Retighten the fasteners when the adjustments are complete.

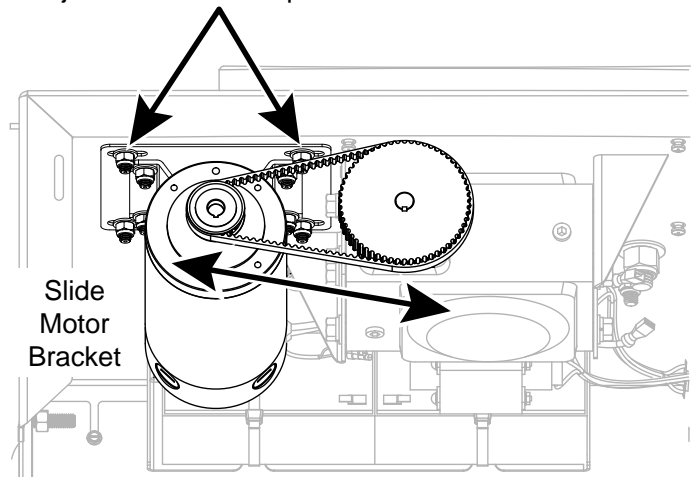

Figure 74. Drive Belt Tension and Alignment

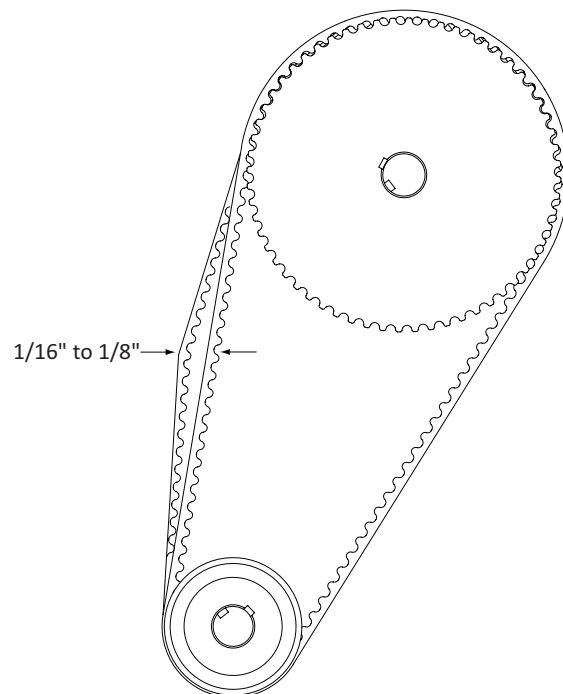

Figure 75. Drive Belt Tension

DC BATTERY REPLACEMENT

HySecurity provides a one year warranty from the date of shipment for all batteries supplied with the SlideSmart operator.

Indicators of a low battery include:

- **LOW BATTERY** or **DEAD BATTERY** appears on the Smart DC Controller display which may or may not be indicative of normal discharge.
- **ALERT 18 CHANGE BATTERY** appears on the Smart DC Controller display. The operator emits an audible chirp every minute to indicate a problem exists.
- **AP (#) AC LOSS** appears on the Smart DC Controller display. Gate operation is affected by AC power loss depending on customer preferences and the configuration set by the installer in the AP (#) AC LOSS User Menu.

NOTICE

For detailed information about the AP AC LOSS configuration, refer to Setting AC Power Loss Gate Function.

Symptoms of a low battery may include:

- Gate remains locked in the open position
- Gate remains locked in the closed position
- Gate opens five seconds after AC power loss and locks open

CAUTION

Before replacing the batteries, turn off all power switches. Use only AGM batteries as replacements (8Ah - MX002008, 50Ah - MX002013). The batteries supplied in the SlideSmart operator are state-of-the-art AGM batteries. Do NOT use flooded cell batteries as damage may occur to the unit. Wear protective clothing while working with batteries.

The two 8Ah batteries are accessible within the operator on a tray behind the control box.

To replace the batteries, take the following steps:

1. Take off the SlideSmart cover and turn off the DC and AC power switches.
2. To access the 8Ah batteries and disconnect its wires, cut the two black wire ties and slide the 8Ah batteries through the access window. See Figure 76.
3. Disconnect the black, blue, and red wires as you slide the batteries through the access window.

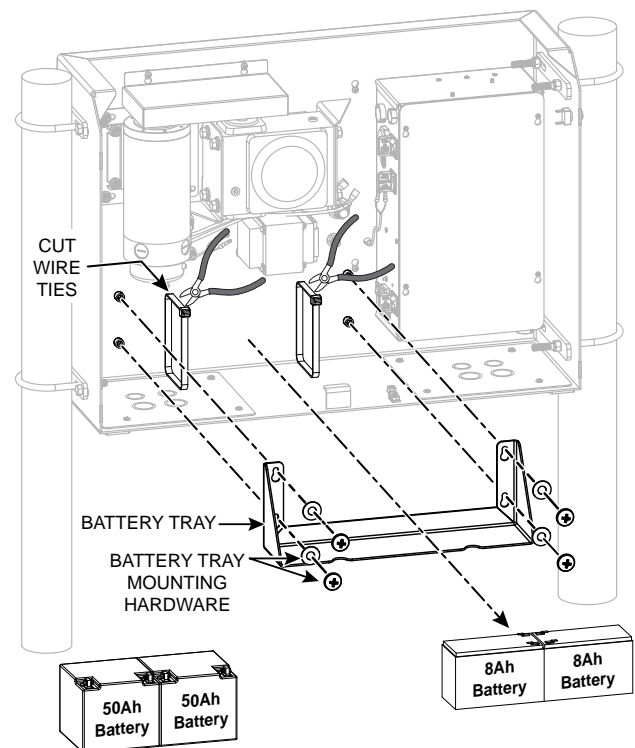

Figure 76. DC Battery Replacement

To install the two new batteries, reverse the removal procedure.

1. Connect the red wire to the red terminal on the left battery and slide the battery onto the tray.
2. Attach the blue wire to the black terminal.
3. Insert the second 8Ah battery and connect the blue wire to the red terminal).
4. As you slide the battery onto the tray, connect the black wire to the black terminal on the right battery. See Figure 77.

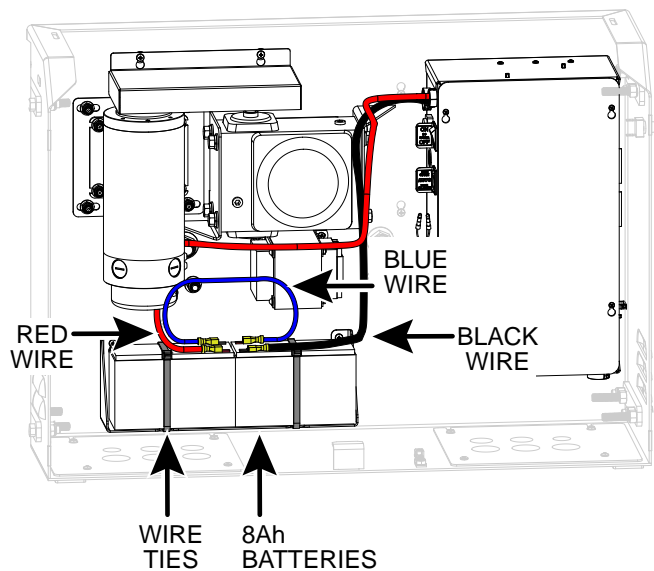

Figure 77. New DC Battery Replacement

CLOCK BATTERY REPLACEMENT

A lithium coin battery supports the clock so the date and time is retained even when the main power is turned off. Replace the battery about every five years (or as needed) with a DL 2025, DL 2032, or CR 2025, or CR 2032 battery. See Figure 78.

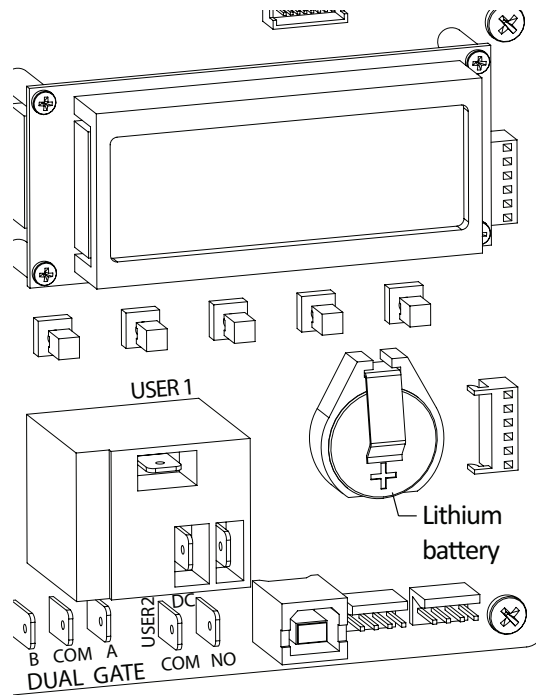

Figure 78. Clock Battery Replacement

APPENDIX A - INSTALLATION CONFIGURATIONS

This appendix contains drawings of the various installation configurations for the SlideSmart operator. Provided in this appendix are drawing specifications for:

- Concrete pad layout and dimensions
- Conduit and ground
- Base extension
- Post mounted
- Post mounted with base extension
- Rear mounted installation

APPENDIX A - INSTALLATION CONFIGURATIONS

SlideSmart HD GENERAL PAD MOUNT DIMENSIONS

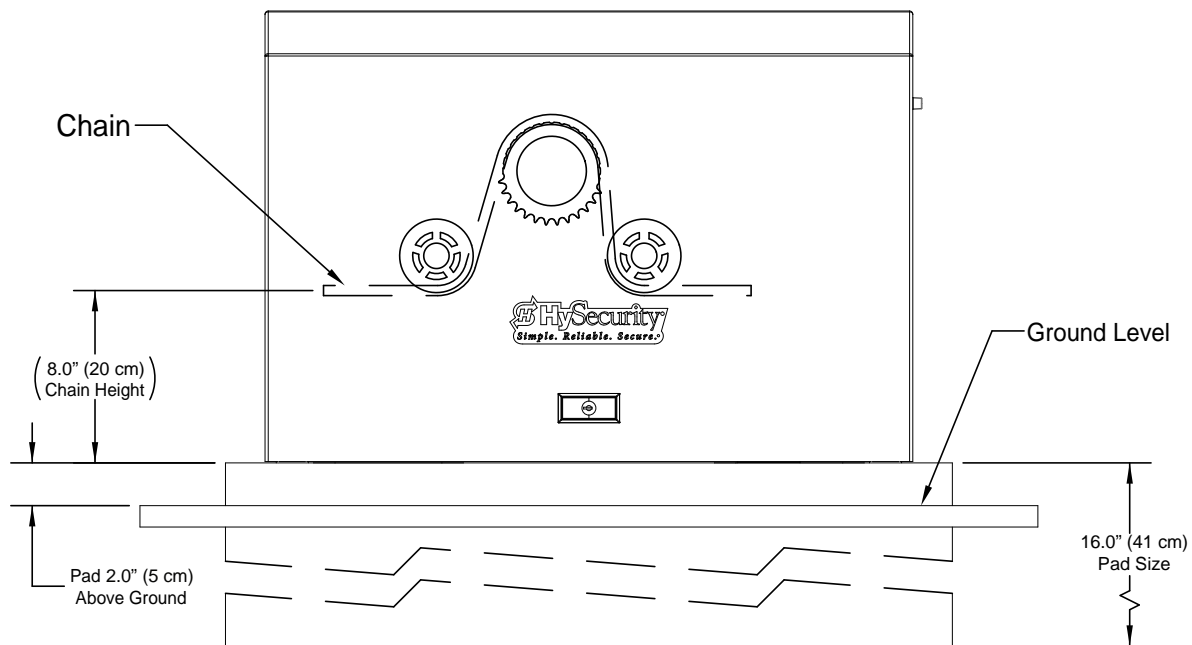
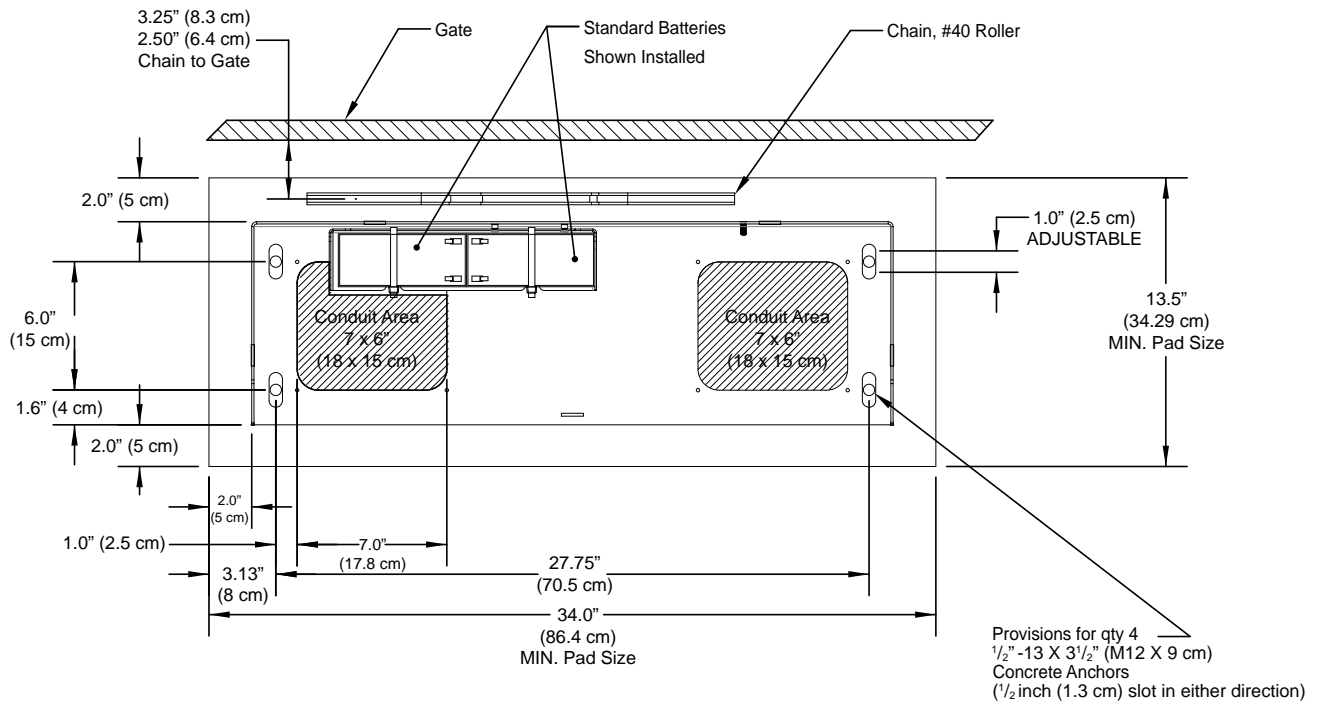

NOTE: DRAWING IS NOT TO SCALE.

Figure 79. General Mounting Dimensions

APPENDIX A - INSTALLATION CONFIGURATIONS

Optional Larger Batteries Reduce Available Conduit Area

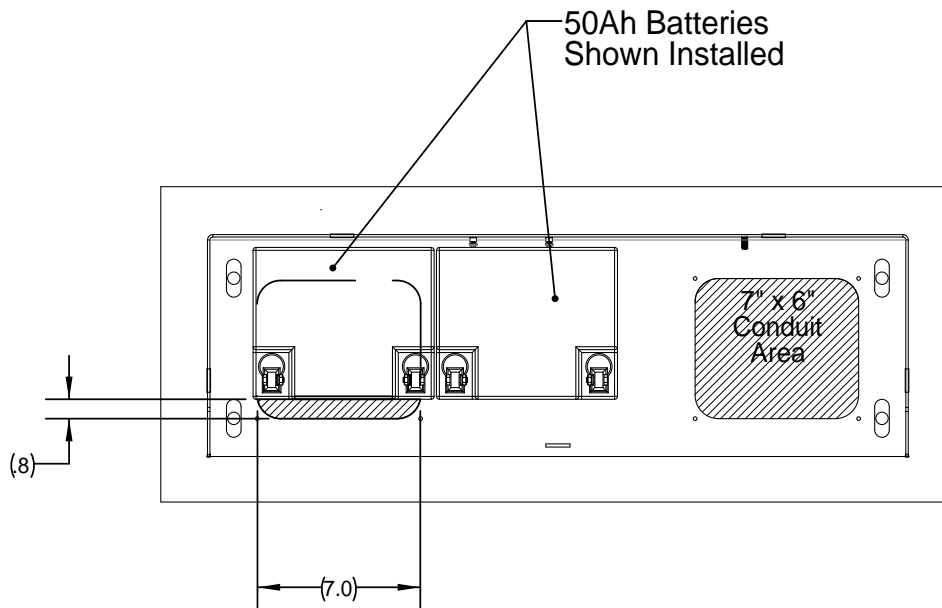
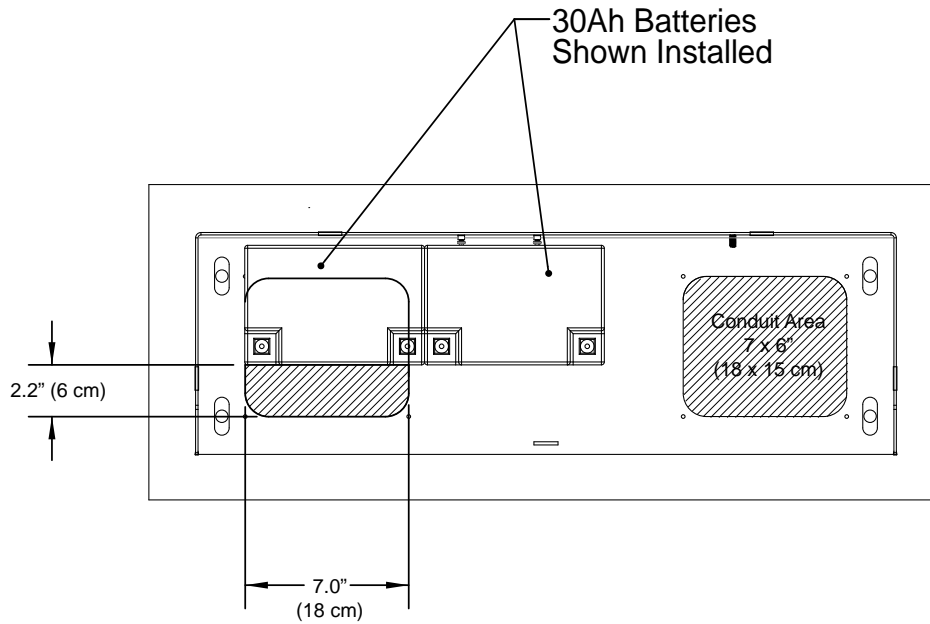

NOTE: DRAWING IS NOT TO SCALE.

Figure 80. Operator Size, Conduit and Grounding Information

SlideSmart HD SIZE, CONDUIT AND GROUNDING INFORMATION

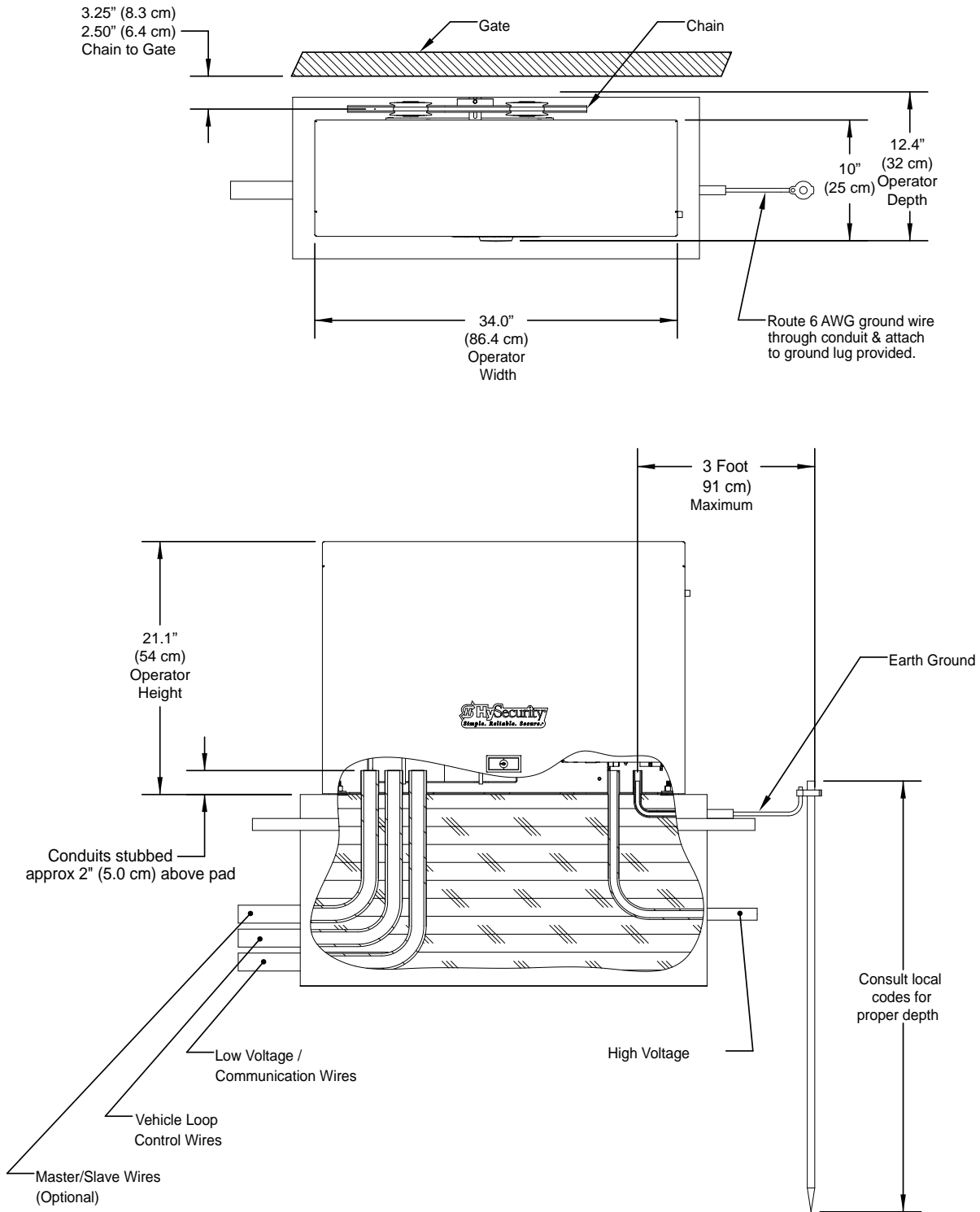

NOTE: DRAWING IS NOT TO SCALE.

Figure 81. Operator Size, Conduit and Grounding Information

APPENDIX A - INSTALLATION CONFIGURATIONS

SLIDESMART HD: POST MOUNTED

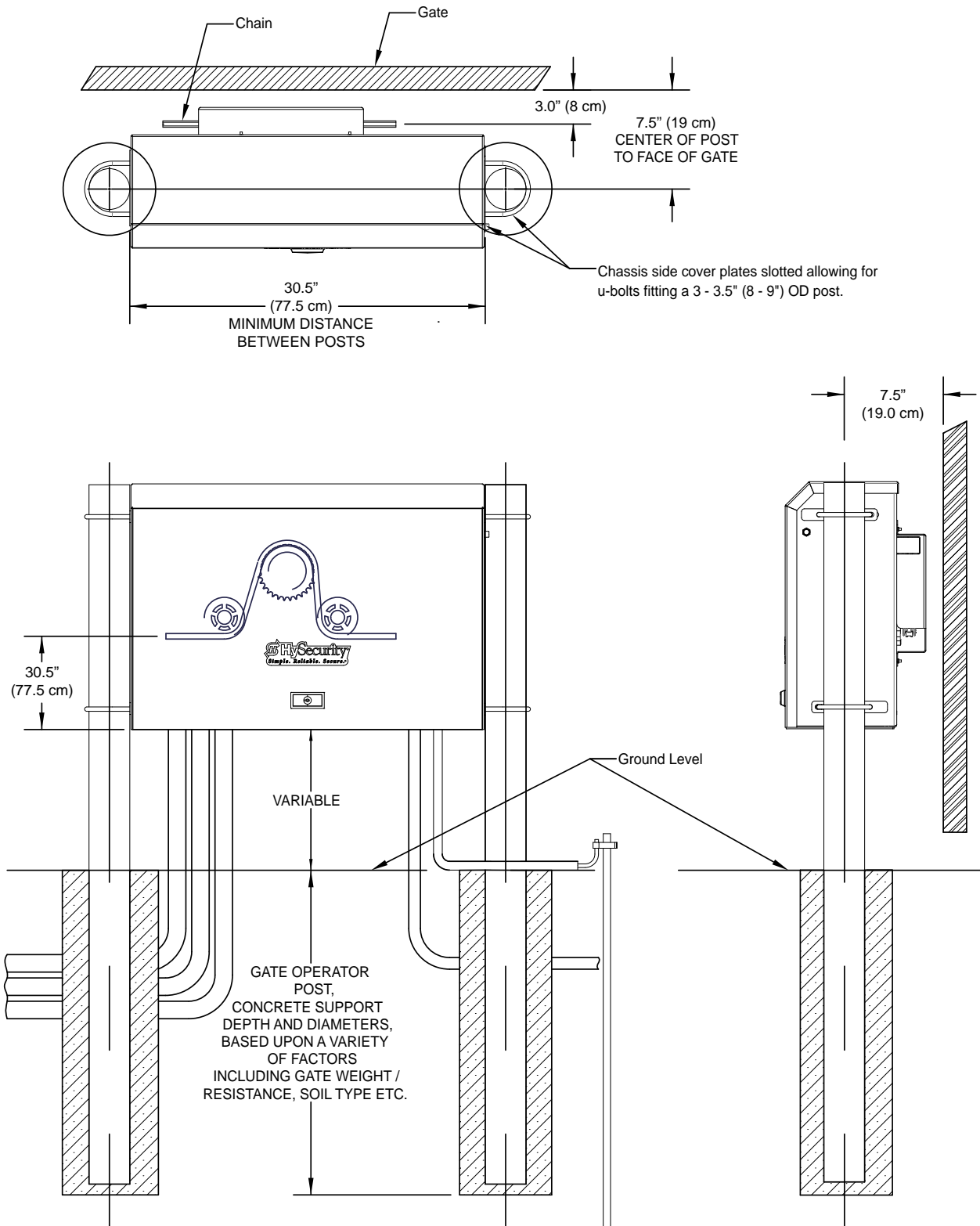
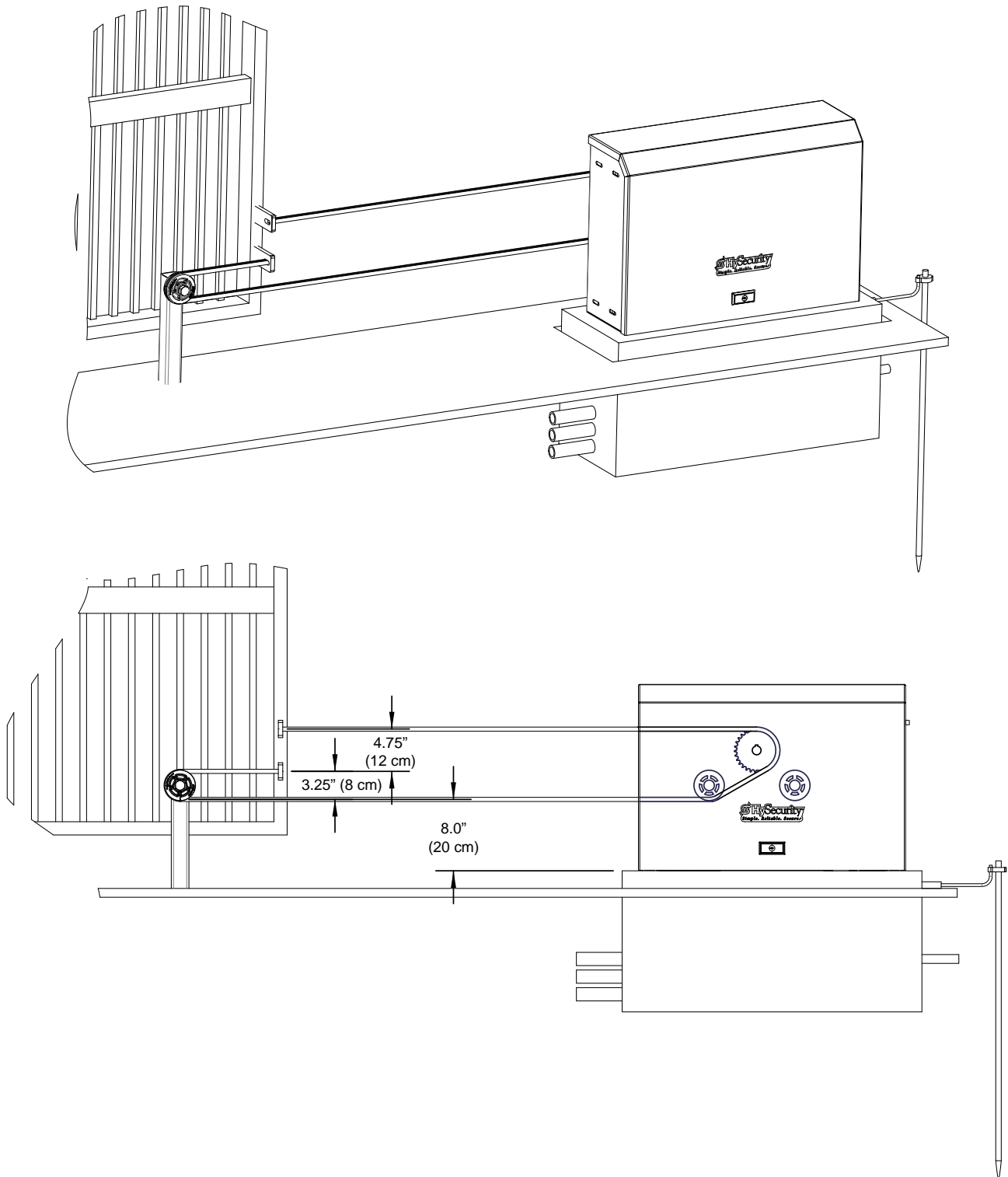

Figure 82. Post Mounted

APPENDIX A - INSTALLATION CONFIGURATIONS

SLIDESMART HD: REAR MOUNTED INSTALLATION



NOTE: DRAWING IS NOT TO SCALE.

Figure 83. Rear Mounted Installation

APPENDIX B - FRENCH TRANSLATIONS

FRENCH TRANSLATIONS

The following French translations provided below are found in the Safety Section located at the beginning of the manual.

English	French
IMPORTANT SAFETY INSTRUCTIONS WARNING – To reduce the risk of injury or death:	INSTRUCTIONS DE SÉCURITÉ IMPORTANTES AVERTISSEMENT – Pour réduire les risques de blessures et de mort :
1. READ AND FOLLOW ALL INSTRUCTIONS.	1. LISEZ CETTE NOTICE ET CONFORMEZ-VOUS AUX MISES EN GARDE
2. Never let children operate or play with gate controls. Keep the remote control away from children.	2. Ne laissez jamais les enfants manoeuvrer les commandes de la barrière ou jouer avec celles-ci. Laissez la télécommande hors de la portée des enfants.
3. Always keep people and objects away from the gate. NO ONE SHOULD CROSS THE PATH OF THE MOVING GATE.	3. Tenez toujours à l'écart de la barrière toute personne ou tout objet avoisinant. IL NE FAUT JAMAIS PASSER DANS LA TRAJECTOIRE D'UNE BARRIÈRE EN MOUVEMENT.
4. Test the gate operator monthly. The gate MUST reverse on contact with a rigid object or stop when an object activates the non-contact sensors. After adjusting the force or the limit of travel, retest the gate operator. Failure to adjust and retest the gate operator properly can increase the risk of injury or death.	4. Vérifiez le fonctionnement de l'ouvre-barrière une fois par mois. Le sens de la course DOIT s'inverser lorsque la barrière entre en contact avec un objet dur ou la barrière DOIT s'arrêter lorsqu'un objet active les capteurs sans contact. Vérifiez à nouveau l'ouvre-barrière après tout réglage de la force de déclenchement ou du seuil de fin de course. Un réglage incorrect de l'ouvre-barrière ou l'omission de vérifier à nouveau le fonctionnement de l'ouvre-barrière peut causer des blessures, voire la mort.
5. Use the emergency release only when the gate is not moving.	5. Ne déclenchez le dispositif de désaccouplement d'urgence que lorsque la barrière ne bouge pas.
6. KEEP GATES PROPERLY MAINTAINED. Read the user's manual. Have a qualified service person make repairs to gate hardware.	6. ASSUREZ-VOUS QUE LA BARRIÈRE EST CORRECTEMENT ENTRETENUE. Lisez le manuel de l'utilisateur. Confiez la réparation du matériel de la barrière à un technicien qualifié.
7. The entrance is for vehicles only. Pedestrians must use separate entrance.	7. La voie d'accès est réservée aux véhicules seulement. Les piétons doivent utiliser une voie d'accès différente.
8. SAVE THESE INSTRUCTIONS.	8. CONSERVEZ CES INSTRUCTIONS.

APPENDIX B - FRENCH TRANSLATIONS

English	French
2.3 Install the gate operator only when:	2.3 N'installez l'ouvre-barrière que si :
a. The operator is appropriate for the construction of the gate and the usage Class of the gate,	a. l'ouvre-barrière est approprié pour la structure et la classe d'utilisation de la barrière;
b. All openings of a horizontal slide gate are guarded or screened from the bottom of the gate to a minimum of 1.83 m (6 ft) above the ground to prevent a 57.2 mm (2-1/4 inch) diameter sphere from passing through the openings anywhere in the gate, and in that portion of the adjacent fence that the gate covers in the open position,	toutes les ouvertures de la barrière coulissante sont protégées ou grillagées du bas de la porte jusqu'à un minimum de 1,83 m (6 pi) du sol si bien qu'une sphère de 57,2 mm (2 1/4 po) de diamètre ne peut passer par une ouverture au niveau de la barrière et de la portion de la clôture adjacente que la barrière couvre en position ouverte;
c. All exposed pinch points are eliminated or guarded, and	c. tous les points de pincement sont éliminés ou protégés;
d. Guarding is supplied for exposed rollers.	d. des protections sont fournies pour les galets exposés.
2.4 The operator is intended for installation only on gates used for vehicles. Pedestrians must be supplied with a separate access opening. The pedestrian access opening shall be designed to promote pedestrian usage. Locate the gate such that persons will not come in contact with the vehicular gate during the entire path of travel of the vehicular gate.	2.4 L'ouvre-barrière est destiné à n'être installé que sur des barrières utilisées pour les véhicules. Il faut fournir une autre voie d'accès aux piétons. La voie d'accès pour les piétons doit être conçue pour favoriser le passage des piétons. Placez la barrière de sorte que personne ne puisse entrer en contact avec la barrière pour les véhicules sur l'ensemble de sa trajectoire
2.5 The gate must be installed in a location so that enough clearance is supplied between the gate and adjacent structures when opening and closing to reduce the risk of entrapment. Swinging gates shall not open into public access areas.	c) Pour réduire les risques de coincement lors de l'ouverture et de la fermeture, la barrière doit être installée dans un endroit où la barrière et les structures avoisinantes sont suffisamment éloignées l'une de l'autre. Les barrières battantes ne doivent pas ouvrir dans une zone d'accès public.

APPENDIX B - FRENCH TRANSLATIONS

English	French
2.6 The gate must be properly installed and work freely in both directions prior to the installation of the gate operator. Do not over-tighten the operator clutch or pressure relief valve to compensate for a damaged gate.	2.6 La barrière doit être bien installée et fonctionner librement dans les deux directions avant d'entreprendre l'installation de l'ouvre-barrière. Ne serrez pas trop l'embrayage ou la soupape de surpression de l'ouvre-barrière pour compenser une barrière endommagée.
2.7 Controls intended for user activation must be located at least 1.83 m (6 ft) away from any moving part of the gate and where the user is prevented from reaching over, under, around or through the gate to operate the controls. Exception: Emergency access controls only accessible by authorized personnel (e.g. fire, police, EMS) may be placed at any location in the line-of-sight of the gate.	2.7 Les commandes destinées à l'activation par l'utilisateur doivent être situées à au moins 1,83 m (6 pi) des pièces mobiles de la barrière et à un endroit où l'utilisateur ne peut pas atteindre les commandes par le dessus, par le dessous, par les côtés et au travers de la barrière. Exception : Les commandes d'accès d'urgence accessibles au personnel autorisé seulement (p. ex. pompier, policier, SMU) peuvent être placées à tout endroit dans le champ de visibilité de la barrière.
2.8 The Stop and/or Reset button must be located in the line of-sight of the gate. Activation of the reset control shall not cause the operator to start.	2.8 Le bouton d'arrêt, le bouton de réenclenchement ou ces deux boutons doivent être situés dans le champ de visibilité de la barrière. L'activation des commandes de réenclenchement ne doit pas mettre en marche l'ouvrebarrière.
2.9 A minimum of two (2) WARNING SIGNS shall be installed, in the area of the gate. Each placard is to be visible by persons located on the side of the gate on which the placard is installed.	2.9 Au moins deux panneaux de mise en garde doivent être installés dans la zone de la barrière. Chaque étiquette doit être visible des personnes situées de chaque côté de la barrière sur laquelle l'étiquette est installée.
2.10 For gate operators utilizing a non-contact sensor	2.10 Pour les ouvre-barrières qui fonctionnent avec des capteurs
a. See instructions on the placement of non-contact sensors for each Type of application,	a. Voir les instructions sur le positionnement des capteurs sans contact pour chaque type d'utilisation.
b. Care shall be exercised to reduce the risk of nuisance tripping, such as when a vehicle, trips the sensor while the gate is still moving, and	b. Des précautions doivent être prises pour réduire les risques de déclenchement inutile, comme lorsqu'un véhicule déclenche le capteur alors que la barrière est encore en mouvement.
c. One or more non-contact sensors shall be located where the risk of entrapment or obstruction exists, such as the perimeter reachable by a moving gate or barrier.	c. Un capteur sans contact ou plus doit être situé où il existe un risque de coincement ou d'obstruction, comme dans l'espace que peut occuper la barrière lorsqu'elle est en mouvement.
2.11 For a gate operator utilizing a contact sensor	2.11 Pour les ouvre-barrières qui fonctionnent avec des capteurs

APPENDIX B - FRENCH TRANSLATIONS

English	French
a. One or more contact sensors shall be located where the risk of entrapment or obstruction exists, such as at the leading edge, trailing edge, and postmounted both inside and outside of a vehicular horizontal slide gate.	a. Au moins un capteur de contact doit être situé où il existe un risque de coincement ou d'obstruction, comme sur le bord d'ouverture, sur le bord de fermeture et sur les poteaux montés sur l'intérieur ou l'extérieur d'une barrière coulissante pour véhicules.
b. A hardwired contact sensor shall be located and its wiring arranged so that the communication between the sensor and the gate operator is not subjected to mechanical damage.	b. Un capteur de contact doit être installé et câblé de sorte à éviter que la communication entre le capteur et l'ouvrebarrière soit gênée par des dommages mécaniques.
c. A wireless device such as one that transmits radio frequency (RF) signals to the gate operator for entrapment protection functions shall be located where the transmission of the signals are not obstructed or impeded by building structures, natural landscaping or similar obstruction. A wireless device shall function under the intended end-use conditions.	c. Un dispositif sans fil, comme un appareil qui transmet des signaux de radiofréquence (RF) à l'ouvre-barrière pour prévenir le coincement, doit être situé à un endroit où la transmission des signaux ne sera pas obstruée ou gênée par des structures, des arbres ou d'autres obstacles similaires. Un dispositif sans fil doit fonctionner selon les conditions d'utilisation finale prévues.
d. One or more contact sensors shall be located on the inside and outside leading edge of a swing gate. Additionally, if the bottom edge of a swing gate is greater than 152 mm (6 inches) but less than 406 mm (16 inches) above the ground at any point in its arc of travel, one or more contact sensors shall be located on the bottom edge.	d. Au moins un capteur de contact doit être situé sur les bords d'ouverture intérieur et extérieur d'une barrière battante. De plus, si le dessous d'une barrière battante est situé à plus de 152 mm (6 po) mais à moins de 406 mm (16 po) du sol à l'un des points de sa trajectoire, au moins un capteur de contact doit être situé sur le bord inférieur.

SLIDESMART PARTS IN PRICE BOOK

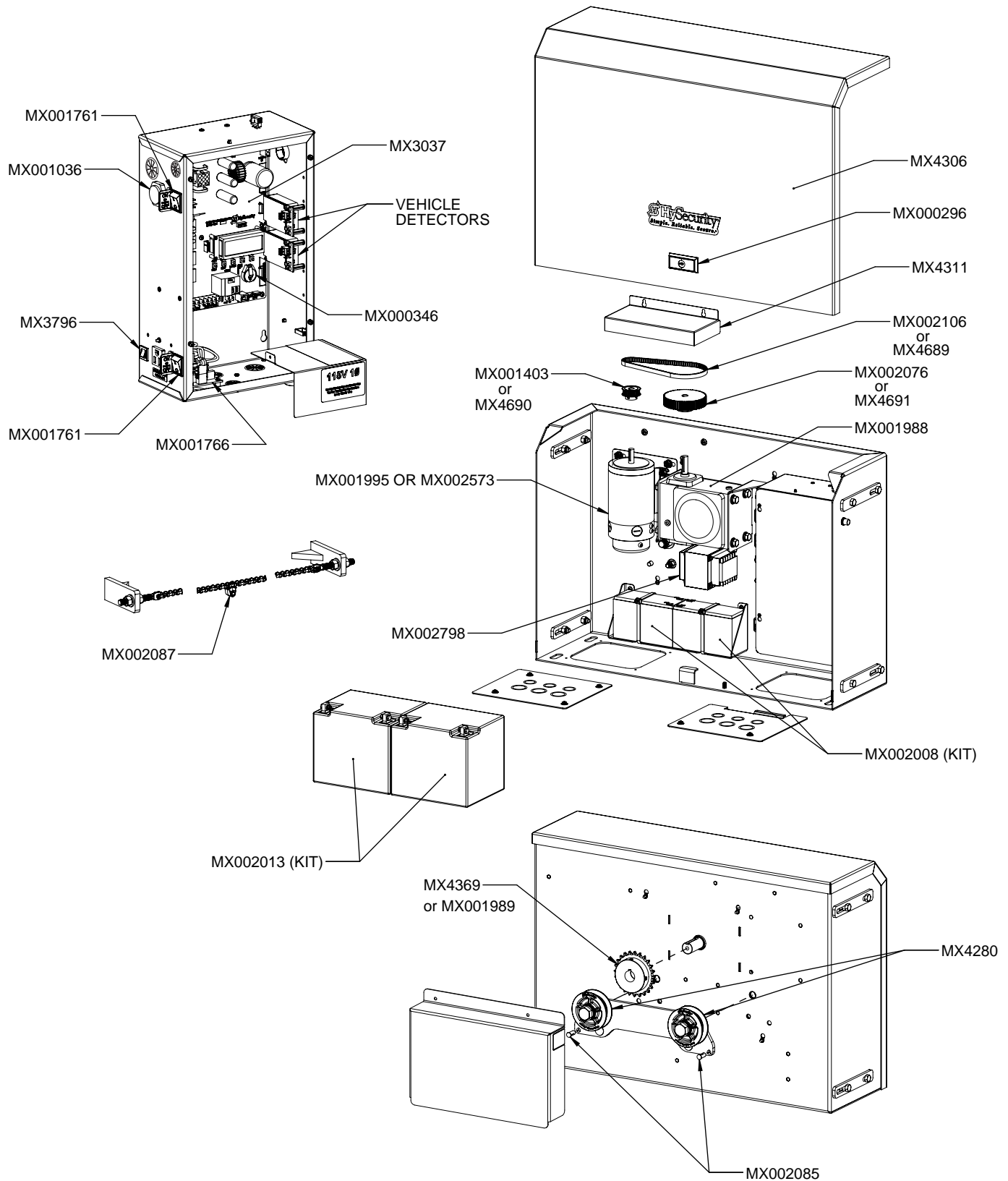

Figure 84. SlideSmart Parts in Price Book

SLIDESMART PARTS LIST

Table 20. SlideSmart Parts List	
Part Name	Part Number
Battery Kit, 50AH, Replacement	MX002013
Battery Kit, 8AH, Replacement	MX002008
Belt, Drive, SlideSmart DC 15	MX002106 or MX4689
Board, Power Supply, 115/230VAC	MX001766
Board, Smart DC Controller	MX001457
Brush Kit, 24VDC Motor	MX001920
Buzzer, Piezo	MX001036
Chain Kit #40, 30 foot (9 m)	MX002113
Circuit Breaker, 3 Amp	MX001762
Cover Assembly SSHD	MX4306
Detector, Vehicle, Hy5B	MX4125
Gearbox, SlideSmart	MX002210
Idler Wheel, #40 Roller Chain Guide	MX4280
Motor, Electric, 24VDC, SlideSmart	MX001995
Motor, 24 VDC, 750W, Hall Effect	MX002573
Pulley, Gearbox, 36T	MX001403 or MX4690
Pulley, Gearbox, 60T	MX002076 or MX4691
Reset Switch, Internal	MX002124
Sprocket, #40 Roller Chain	MX002211
Switch, On/Off	MX001761
Target, Magnet, SlideSmart	MX002087
Target, Sensor Switch, SlideSmart	MX002085
Transformer, 115/230VAC	MX001682

WARRANTY

1. Warranty.

Hy-Security Gate, Inc. ("HySecurity") warrants that at the time of sale each HySecurity-branded product that it sells will, in all material respects, conform to its then applicable specification and will be free from defects in material and manufacture.

The following additional durational warranties apply to HySecurity products, depending on whether (1) the product is purchased through an authorized HySecurity distributor and (2) whether a timely and complete product registration is submitted to HySecurity.

It is therefore important that you register your product with HySecurity, online at www.hysecurity.com/warranty, within the 60-day period described below.

1(a) HySecurity Products Purchased Through Authorized Distributors and Properly Registered

For any gate operator product that is purchased from an authorized HySecurity distributor (this excludes product purchased through internet resellers or any distributor not authorized by HySecurity), if the product registration is completed by the Dealer/Installer or End User within 60 days of the date of purchase, the following warranty terms will apply. HySecurity warrants that the product will remain serviceable for the following periods:

- a) Hydraulic industrial gate operator hydraulics, controls, and mechanical components: Five Years or 500,000 gate cycles (whichever occurs first) after the date of installation,
- b) Hydraulic wedge operator hydraulics and controls: Five Years or 500,000 cycles (whichever occurs first) after the date of installation. Wedge mechanical components: Two Years after the date of installation,
- c) Electromechanical pad-mounted Slide and Swing operators: Five Years or 500,000 cycles (whichever occurs first) after the date of installation, except single family residential usage, where the warranty term shall be Seven Years after the date the product was shipped from HySecurity,
- d) Electromechanical linear actuator Swing operators: Two Years after the date of installation,
- e) Electromechanical surface mount wedge operator electronics: Two Years or 500,000 gate cycles (whichever occurs first), after the date of installation,
- f) Electromechanical Barrier Arm Operators: Two years or 1,000,000 gate cycles (whichever occurs first) after the date of installation,

provided that the preceding Five Year warranty period in (a), (b), and (c) will not extend beyond seven years from the date that the product was shipped from HySecurity, and the Two Year warranty period in (b), (d), (e), and (f) will not extend beyond four years from the date that the product was shipped from HySecurity.

The preceding warranty durations do not apply to the products or components described below (g-j), which have a shorter warranty period:

- g) Hydraulic gate operator drive wheels, including XtremeDrive™ wheels and rack: Two Years from date of installation.
- h) AC and DC power supplies, chargers, and inverters and HyNet™ Gateway: Two Years from date of installation, except batteries.
- i) Batteries: One Year from date of shipment from HySecurity.
- j) Components subject to normal wear including, but not limited to, chains, belts, idler wheels, sprockets and fuses: One Year from date of installation.

1(b) HySecurity Products Not Purchased Through an Authorized Distributor or Not Properly Registered within 60 Days

For any product that is not purchased from an authorized HySecurity distributor or for which the product registration was not completed by the Dealer/Installer/End User within sixty (60) days of the date of purchase, the following warranty will apply: HySecurity warrants that the product will remain serviceable for the following periods, which begin on the date that the product was shipped from HySecurity:

- a) All gate operators: One Year or 100,000 gate cycles, whichever comes first.
- b) AC and DC power supplies, chargers, or inverters: One Year.
- c) HyNet™ Gateway: One Year.
- d) Hydraulic gate operator drive wheels: One Year.

1(c) Replacement Parts

HySecurity warrants that replacement parts (whether new or reconditioned) will remain serviceable for One Year from the date that the part was shipped from HySecurity or the remaining period of the Gate Operator warranty, whichever is longer.

1(d) Limitations and Exclusions Applicable to Each of the Preceding Warranties.

The preceding warranties shall not apply to equipment that has been (1) installed, maintained, or used improperly or contrary to instructions; (2) subjected to negligence, accident, vandalism, or damaged by severe weather, wind, flood, fire,

terrorism or war; or (3) damaged through improper operation, maintenance, storage or abnormal or extraordinary use or abuse. Any modification made to products will void the warranty unless the modifications are approved in writing by HySecurity in advance of the change (this exclusion does not apply to normal installation of approved accessories and/or protective devices or sensors). It is the responsibility of the Distributor, Dealer/Installer, or End User to ensure that the software version in the product is maintained to the latest revision level.

The preceding warranties do not extend to accessories when those items carry another manufacturer's name plate and they are not a part of the base model. HySecurity disclaims all warranties for such accessory components, which carry only the original warranty, if any, of their original manufacturer. HySecurity hereby assigns its rights under such manufacturer warranties—to the extent that such rights are assignable—to Buyer.

These warranties extend to HySecurity's Distributors, to the Dealer/Installer, and to the first End User of the product following installation. They do not extend to subsequent purchasers.

2. Exclusion of Other Warranties.

The warranties contained in Section 1 are the exclusive warranties given by HySecurity and supersede any prior, contrary or additional representations, whether oral or written. Any prior or extrinsic representations or agreements are discharged or nullified. HYSECURITY HEREBY DISCLAIMS AND EXCLUDES ALL OTHER WARRANTIES—WHETHER EXPRESS, IMPLIED, OR STATUTORY—INCLUDING ANY WARRANTY OF MERCHANTABILITY, ANY WARRANTY OF FITNESS FOR A PARTICULAR PURPOSE, ANY LIABILITY FOR INFRINGEMENT, AND ANY WARRANTIES OTHERWISE ARISING FROM COURSE OF DEALING, COURSE OF PERFORMANCE, OR USAGE OF TRADE.

3. Buyer's Exclusive Remedies for Any Nonconformity.

If a HySecurity product fails to conform to the warranties in Section 1, Buyer must notify and order replacement parts from the Distributor through which the product was purchased within a reasonable time and in no event more than thirty (30) days after the discovery of the nonconformity. HySecurity will investigate and, in the event of a breach, will provide, within a reasonable period of time, one of the following: (1) repair or replacement of any nonconforming products or components or (2) refund of the price upon return of the nonconforming items. HySecurity reserves the right to supply used or reconditioned material for all warranty claims. HySecurity will not be considered to be in breach of or default under this Warranty because of any failure to perform due to conditions beyond its reasonable control, including any force majeure. This warranty does not cover any incidental expenses, including fines or penalties, temporary security, labor, shipping, travel time or standby time that are incurred for inspection or replacement of any nonconforming items. As a condition of warranty coverage, warranty claims must be submitted in accordance with the procedures described on the HySecurity form, "RMA Procedures."

THE REMEDY SELECTED BY HYSECURITY IN ACCORDANCE WITH THIS PARAGRAPH SHALL BE THE EXCLUSIVE AND SOLE REMEDY OF BUYER FOR ANY BREACH OF WARRANTY.

4. Exclusion of Consequential and Incidental Damages.

HYSECURITY SHALL NOT BE LIABLE FOR ANY INCIDENTAL, SPECIAL, OR CONSEQUENTIAL DAMAGES, WHETHER RESULTING FROM NONDELIVERY OR FROM THE USE, MISUSE, OR INABILITY TO USE THE PRODUCT OR FROM DEFECTS IN THE PRODUCT OR FROM HYSECURITY'S OWN NEGLIGENCE. This exclusion applies regardless of whether such damages are sought for breach of warranty, breach of contract, negligence, or strict liability. This exclusion does not apply to claims for bodily injury or death.

5. Severability.

If any provision of this warranty is found to be invalid or unenforceable, then the remainder shall have full force and effect.

6. Proprietary Rights.

HySecurity retains and reserves all right, title, and interest in the intellectual property rights of its products, including any accompanying proprietary software. No ownership of any intellectual property rights in the products or accompanying software is transferred to Distributor, Dealer/Installer, or End User.

7. Applicable Law.

This warranty will be interpreted, construed, and enforced in all respects in accordance with the laws of the State of Washington, without reference to its choice of law principles. The U.N. Convention on Contracts for the International Sale of Goods will not apply to this warranty.

3 SlideSmart™ HD Models

	FAST		
Model	SlideSmart HD15F	SlideSmart HD25	SlideSmart HD30
Gate Weight Max.	1,500 lb (680 kg)	2,500 lb (1,134 kg)	3,000 lb (1,361 kg)
Gate Length Max.	50 ft (15 m)		
Pull Force*	300 lb	450 lb	500 lb
Rate of Travel	1.75, 2 or 2.25 ft/s (53, 61 or 69 cm/s) Open/Close speed set independently	0.75, 1 or 1.25 ft/s (23, 30 or 38 cm/s) Open/Close speed set independently	
Duty Cycle	Continuous		
Horsepower	1 hp	1/2 hp	1 hp
Drive	Electromechanical		
UPS Battery Backup Cycles †	Field configurable to fail open or secure when batteries deplete. Standard battery backup gate travel: Two 8Ah batteries. Up to 4,000 ft (1,219 m) after AC power loss. Extended battery backup gate travel: Two 50Ah batteries. Up to 25,000 ft (7,620 m) after AC power loss.		
Temperature Rating	-13° to 158° F (-25° to 70° C)		
Operating Voltage	24VDC		
Input Voltage	115V or 208-230V, 60/50 Hz		
Accessory Power	12VDC and 24VDC 1A each		
Communication	USB, RS-232, RS-485. Ethernet/fiber using optional HyNet™ Gateway accessory		
User Controls	Smart DC Controller with 70+ configurable settings. 32 character LCD display and 5 tact buttons or a PC using S.T.A.R.T. software.		
Relays	Two configurable user relays: 30VDC, 3A solid state and 250VAC, 10A electromechanical; Optional Hy8Relay™ for 8 additional relay outputs		
Finish	Zinc rich primer and black powder coated steel cover/chassis		
ETL Listed (UL 325)	Usage Class III, IV***	Usage Class I, II, III, IV**	
Cycle Tested	500,000 cycles		
Warranty	5 year w/product registration	5 year (7 year single-family residential) w/product registration	

* HySecurity manufactures only reliable and powerful gate operators and provides an extra margin of power to be certain the gate works in adverse conditions. Some manufactures overstate the length and weight capacity of their operators, but HySecurity rates conservatively. Note that our pull force ratings are substantial and that extra margin of power is part of the HySecurity reputation for reliability.

** Speed setting cannot be configured to exceed 1 ft/s for Class I and II usage.

***Not for residential use or applications intended to serve the general public.

† The actual number of gate cycles available from battery depends upon gate resistance to travel, cycle length, battery size, state of charge and health, ambient temperature, accessory power draw and frequency of gate cycles during power outage.

To enable fully automatic operation, all SLIDE gate operators require a minimum of TWO monitored external entrapment protection sensors (one for each direction) to protect entrapment zones in both the open and close direction of travel. Visit www.hysecurity.com/gatesafety for more information on UL 325 standards and gate safety.