

Technical Bulletin

New 8" AdvanceDrive Wheels

OPERATORS: SlideDriver™ operator models using 8" AdvanceDrive™ wheels

SUBJECT: New 8" aluminum AdvanceDrive wheels

SUBJECT DESCRIPTION: The 8" AdvanceDrive wheels used in SlideDriver models have been replaced with new wheels that do not require a metal retaining plate.

IMPACT: Simpler disassembly during maintenance.

Figures 1 and 2 (below) show the differences between old and new AdvanceDrive wheel assemblies.

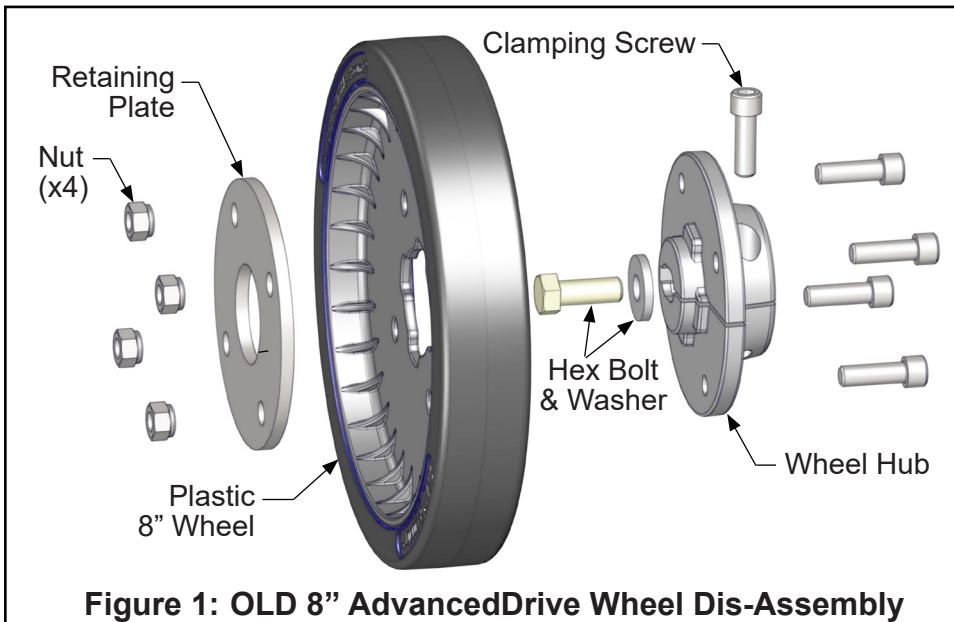

Figure 1: OLD 8" AdvancedDrive Wheel Dis-Assembly

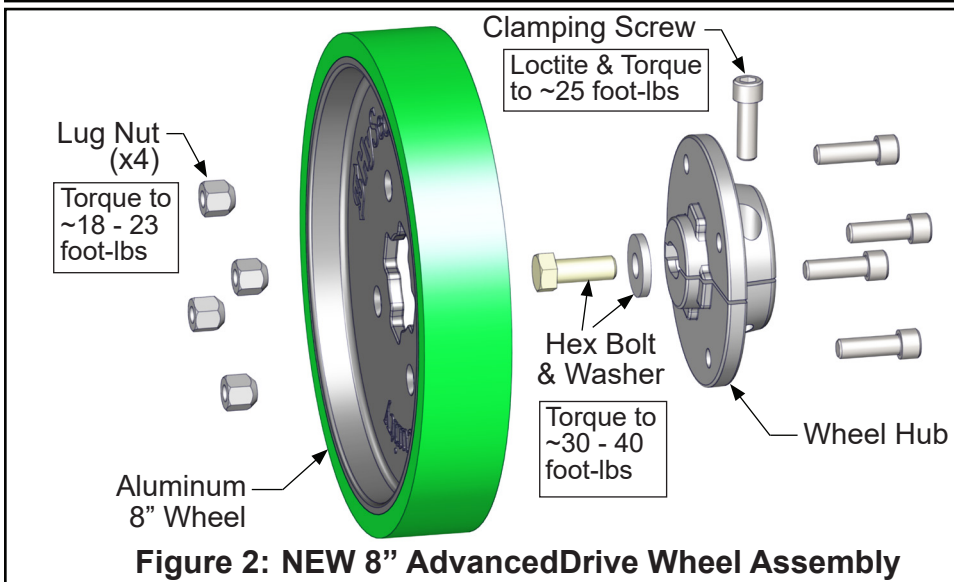

Figure 2: NEW 8" AdvancedDrive Wheel Assembly

Part Numbers

Use the part numbers below to order 8" AdvanceDrive replacement kits.

To replace original aluminum wheels use:

P/N **MX3132** AdvanceDrive, 8" Wheel, Hub, & Nuts

- wheel hub
- hub hardware (hex bolt, washer, clamping screw)
- new 8" aluminum wheel
- lug nuts (x4)

To replace plastic wheels use:

P/N **MX5223** AdvanceDrive, 8" Wheel & Nuts

- new 8" aluminum wheel
- lug nuts (x4)

For lug nuts, use:

P/N **MX4993**

Lug Nut, 82 Deg, 5/16-24

- lug nuts (x4)

NOTE: New aluminum wheels are compatible with the wheel hubs used with plastic wheels, but require the longer lug nuts (P/N MX4993).